



Installation Instructions

ControlLogix Ethernet Communication Interface Module

Catalog Number 1756-ENET/B

Use this manual as a guide to install the ControlLogix™ Ethernet™ Communication Interface Module. This table identifies what this manual contains and where to find specific information.

Topic	Page
Important User Information	2
Identifying Module Components	6
Preparing the Chassis for Module Installation	6
Determining Module Slot Location	7
Installing the Module in the Chassis	8
Removing or Replacing the Module (when applicable)	9
Installing or Removing the Module While Power Is Applied	10
Wiring the Ethernet Connector	10
Connecting the Module to the Ethernet Network	11
Applying Chassis Power	12
Checking Power Supply and Module Status	13
Troubleshooting the Module	14
Where to Find Information on Configuring the Ethernet Module	14
Hazardous Location Information	15
Specifications	16

Important User Information

Because of the variety of uses for the products described in this publication, those responsible for the application and use of these products must satisfy themselves that all necessary steps have been taken to assure that each application and use meets all performance and safety requirements, including any applicable laws, regulations, codes and standards. In no event will Rockwell Automation be responsible or liable for indirect or consequential damage resulting from the use or application of these products.

Any illustrations, charts, sample programs, and layout examples shown in this publication are intended solely for purposes of example. Since there are many variables and requirements associated with any particular installation, Rockwell Automation does not assume responsibility or liability (to include intellectual property liability) for actual use based upon the examples shown in this publication.

Allen-Bradley publication SGI-1.1, *Safety Guidelines for the Application, Installation and Maintenance of Solid-State Control* (available from your local Rockwell Automation office), describes some important differences between solid-state equipment and electromechanical devices that should be taken into consideration when applying products such as those described in this publication.

Reproduction of the contents of this copyrighted publication, in whole or part, without written permission of Rockwell Automation, is prohibited.

Throughout this publication, notes may be used to make you aware of safety considerations. The following annotations and their accompanying statements help you to identify a potential hazard,

avoid a potential hazard, and recognize the consequences of a potential hazard:

WARNING

Identifies information about practices or circumstances that can cause an explosion in a hazardous environment, which may lead to personal injury or death, property damage, or economic loss.

ATTENTION

Identifies information about practices or circumstances that can lead to personal injury or death, property damage, or economic loss.

IMPORTANT

Identifies information that is critical for successful application and understanding of the product.

ATTENTION



Environment and Enclosure

This equipment is intended for use in a Pollution Degree 2 industrial environment, in overvoltage Category II applications (as defined in IEC publication 60664-1), at altitudes up to 2000 meters without derating.

This equipment is supplied as "open type" equipment. It must be mounted within an enclosure that is suitably designed for those specific environmental conditions that will be present and appropriately designed to prevent personal injury resulting from accessibility to live parts. The interior of the enclosure must be accessible only by the use of a tool. Subsequent sections of this publication may contain additional information regarding specific enclosure type ratings that are required to comply with certain product safety certifications.

See NEMA Standards publication 250 and IEC publication 60529, as applicable, for explanations of the degrees of protection provided by different types of enclosure. Also, see the appropriate sections in this publication, as well as the Allen-Bradley publication 1770-4.1 ("Industrial Automation Wiring and Grounding Guidelines"), for additional installation requirements pertaining to this equipment.

ATTENTION**Preventing Electrostatic Discharge**

This equipment is sensitive to electrostatic discharge, which can cause internal damage and affect normal operation. Follow these guidelines when you handle this equipment:

- Touch a grounded object to discharge potential static.
 - Wear an approved grounding wriststrap.
 - Do not touch connectors or pins on component boards.
 - Do not touch circuit components inside the equipment.
 - If available, use a static-safe workstation.
 - When not in use, store the equipment in appropriate static-safe packaging.
-

European Zone 2 Certification

This equipment is intended for use in potentially explosive atmospheres as defined by European Union Directive 94/9/EC.

The LCIE (Laboratoire Central des Industries Electriques) certifies that this equipment has been found to comply with the Essential Health and Safety Requirements relating to the design and construction of Category 3 equipment intended for use in potentially explosive atmospheres, given in Annex II to this Directive. The examination and test results are recorded in confidential report No. 28 682 010.

Compliance with the Essential Health and Safety Requirements has been assured by compliance with EN 50021 (1999).

Identifying Module Components

Use this illustration to identify the external features of the Ethernet module.

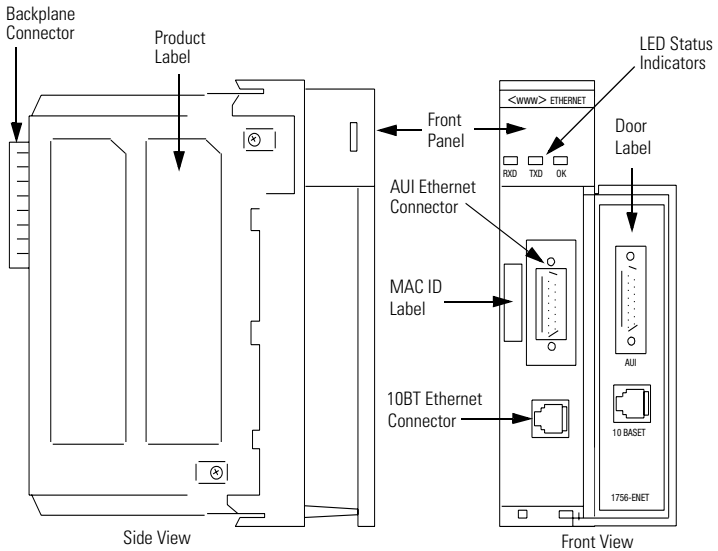

Preparing the Chassis for Module Installation

Before you install the Ethernet module, you must install and connect a ControlLogix chassis and power supply.

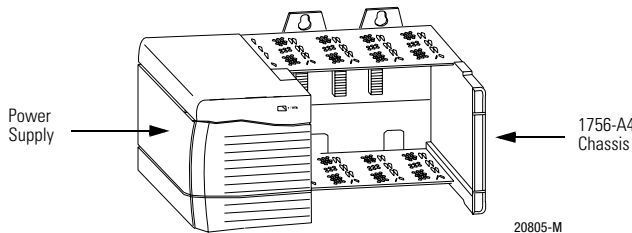

For information about installing these products, refer to the publications listed in this table.

Chassis Type	Chassis Installation	Power Supply	Power Supply Installation
Series B: 1756-A4, -A7, -A10, -A13, -A17	Pub. No. 1756-IN080	1756-PA72/B	Pub. No. 1756-5.67
		1756-PB72/B	
		1756-PA75/A	Pub. No. 1756-5.78
		1756-PB75/A	

Determining Module Slot Location

You can install the module in any slot in the ControlLogix chassis. You can also install multiple ENET modules in the same chassis. The figure below shows chassis slot numbering in a 4-slot chassis. Slot 0 is the first slot and is always the leftmost slot in the rack (the first slot to the right of the power supply).

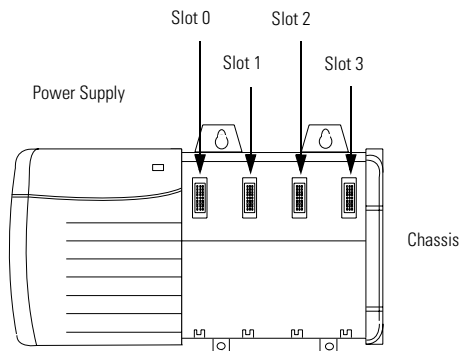

Installing the Module in the Chassis

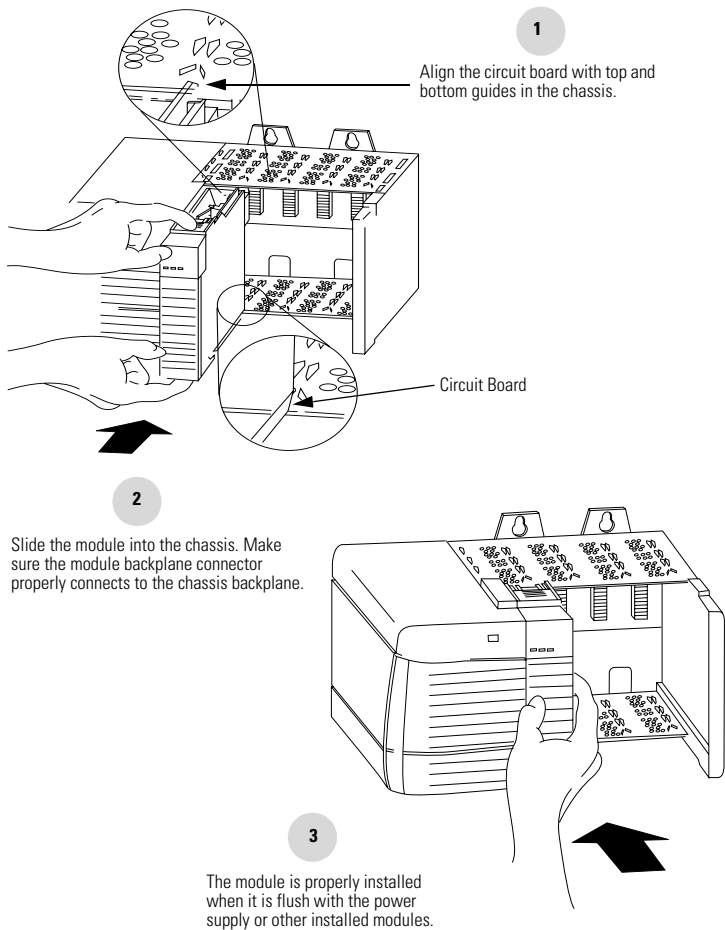

Removing or Replacing the Module (when applicable)

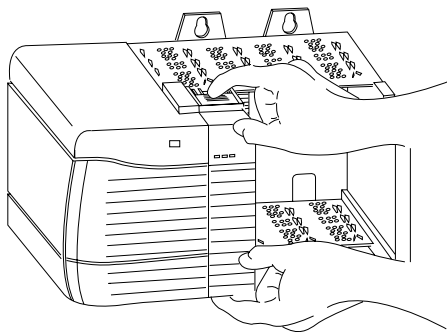

1

Push on upper and lower module tabs to disengage them.

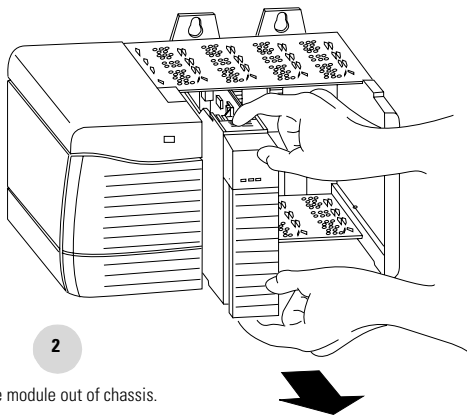

2

Slide module out of chassis.

IMPORTANT

If you are replacing an existing module with an identical one, and you want to resume identical system operation, you must install the new module in the same slot.

Installing or Removing the Module While Power Is Applied

You can install or remove the module while chassis power is applied. Please observe the following precautions.

WARNING



When you insert or remove the module while backplane power is on, or you connect or disconnect the communications connectors, an electrical arc can occur. This could cause an explosion in hazardous location installations. Be sure that power is removed or the area is nonhazardous before proceeding.

Repeated electrical arcing causes excessive wear to contacts on both the module and its mating connector. Worn contacts may create electrical resistance that can affect module operation.

Wiring the Ethernet Connector

Use either an AUI or an RJ45 connector to connect to the Ethernet network.

For detailed Ethernet connection information, see the EtherNet/IP Performance and Application Guide, publication ENET-IN001.

Wire the appropriate connector according to this illustration.

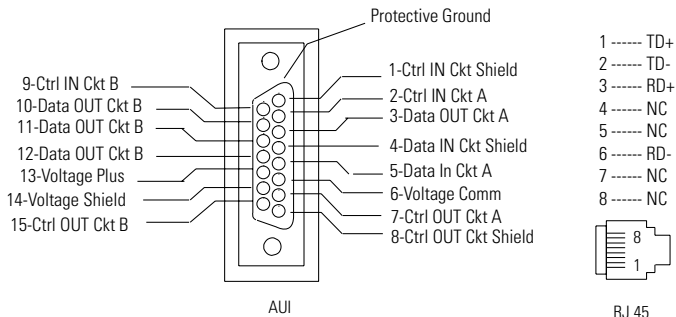

Connecting the Module to the Ethernet Network

WARNING



If you connect or disconnect the Ethernet cable with power applied to this module or any device on the network, an electrical arc can occur. This could cause an explosion in hazardous location installations. Be sure that power is removed or the area is nonhazardous before proceeding.

Attach the AUI or RJ45 connector to the matching Ethernet port:

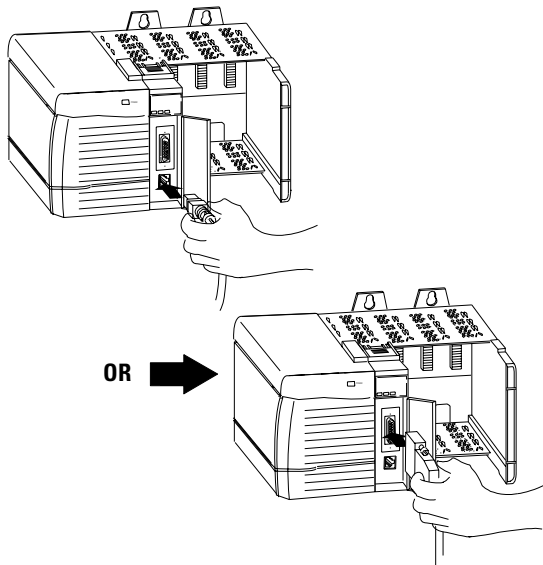

IMPORTANT

Connecting the module to the network via an Ethernet switch will reduce collisions and lost packets and increase network bandwidth. See the EtherNet/IP Performance and Application Guide, publication ENET-AP001, for more information.

If your application requires the module door to be closed, use one of these custom AUI connector cables available in two lengths:

- 2 meters (catalog number 1756-TC02), or
- 15 meters (catalog number 1756-TC15).

Applying Chassis Power

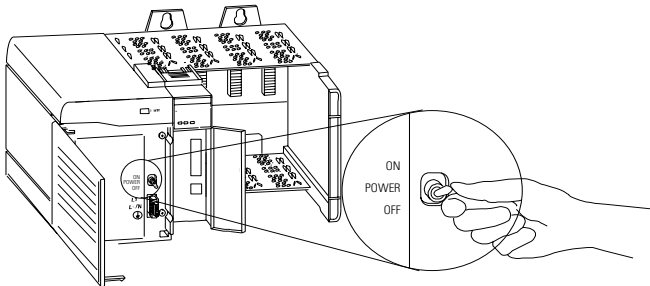

Checking Power Supply and Module Status

Check the LED indicators to determine if the power supply and module are operating properly.

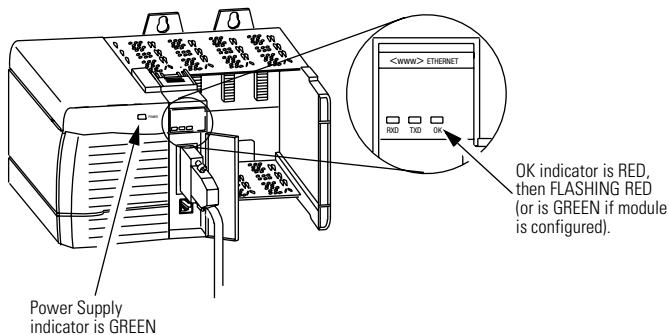

If the Power Supply and OK indicators are not in the states described above refer to the following troubleshooting section.

Troubleshooting the Module

This table describes module health (OK) indicator displays, module status, and recommended action:

If the OK indicator is	then module status is	take this action
Off	Not operating.	Apply chassis power. Verify module is completely inserted into chassis and backplane.
Red, then flashing red or flashing green	Performing powerup diagnostics.	None, normal operation.
Green	Operating.	None.
Red flashing	Not configured.	Configure module (refer to the configuration chapter of your ControlLogix Ethernet Communication Interface Module User Manual, publication 1756-UM051)
Red	Unrecoverable fault.	Repair or replace module.



This table describes the transmit (TXD) and receive (RXD) indicator display:

If this indicator	is	the module is
TXD	Green	Transmitting data
	Off	Not active
RXD	Green	Receiving data
	Off	Not active

Where to Find Information on Configuring the Ethernet Module

Now that you have installed your Ethernet module, you must configure it with an IP Address, Subnet Mask, and Gateway Address. Refer to the configuration chapter of your ControlLogix Ethernet Communication Interface Module User Manual, publication 1756-UM051.

Hazardous Location Information

The following information applies when operating this equipment in hazardous locations:	Informations sur l'utilisation de cet équipement en environnements dangereux :		
<p>Products marked "CL I, DIV 2, GP A, B, C, D" are suitable for use in Class I Division 2 Groups A, B, C, D, Hazardous Locations and nonhazardous locations only. Each product is supplied with markings on the rating nameplate indicating the hazardous location temperature code. When combining products within a system, the most adverse temperature code (lowest "T" number) may be used to help determine the overall temperature code of the system. Combinations of equipment in your system are subject to investigation by the local Authority Having Jurisdiction at the time of installation.</p>	<p>Les produits marqués "CL I, DIV 2, GP A, B, C, D" ne conviennent qu'à une utilisation en environnements de Classe I Division 2 Groupes A, B, C, D dangereux et non dangereux. Chaque produit est livré avec des marquages sur sa plaque d'identification qui indiquent le code de température pour les environnements dangereux. Lorsque plusieurs produits sont combinés dans un système, le code de température le plus défavorable (code de température le plus faible) peut être utilisé pour déterminer le code de température global du système. Les combinaisons d'équipements dans le système sont sujettes à inspection par les autorités locales qualifiées au moment de l'installation.</p>		
<p style="text-align: center;">WARNING</p> 	<p>EXPLOSION HAZARD</p> <ul style="list-style-type: none"> • Do not disconnect equipment unless power has been removed or the area is known to be nonhazardous. • Do not disconnect connections to this equipment unless power has been removed or the area is known to be nonhazardous. Secure any external connections that mate to this equipment by using screws, sliding latches, threaded connectors, or other means provided with this product. • Substitution of components may impair suitability for Class I, Division 2. • If this product contains batteries, they must only be changed in an area known to be nonhazardous. 	<p style="text-align: center;">AVERTISSEMENT</p> 	<p>RISQUE D'EXPLOSION</p> <ul style="list-style-type: none"> • Couper le courant ou s'assurer que l'environnement est classé non dangereux avant de débrancher l'équipement. • Couper le courant ou s'assurer que l'environnement est classé non dangereux avant de débrancher les connecteurs. Fixer tous les connecteurs externes reliés à cet équipement à l'aide de vis, loquets coulissants, connecteurs filetés ou autres moyens fournis avec ce produit. • La substitution de composants peut rendre cet équipement inadapté à une utilisation en environnement de Classe I, Division 2. • S'assurer que l'environnement est classé non dangereux avant de changer les piles.

Specifications

Module Location	Any slot in the ControlLogix chassis
Maximum Backplane Current Load	900mA @ 5.1V dc 350mA @ 24V dc from I/O chassis backplane
Power Dissipation	13.3W maximum
Operating Temperature	IEC 60068-2-1 (Test Ad, Operating Cold), IEC 60068-2-2 (Test Bd, Operating Dry Heat), IEC 60068-2-14 (Test Nb, Operating Thermal Shock): 0 to 60°C (32 to 140°F)
Storage Temperature	IEC 60068-2-1 (Test Ab, Un-packaged Non-operating Cold), IEC 60068-2-2 (Test Bb, Un-packaged Non-operating Dry Heat), IEC 60068-2-14 (Test Na, Un-packaged Non-operating Thermal Shock): -40 to 85°C (-40 to 185°F)
Relative Humidity	IEC 60068-2-30 (Test Db, Un-packaged Non-operating Damp Heat): 5 to 95% non-condensing
Shock	IEC 60068-2-27 (Test Ea, Unpackaged Shock): Operating 30g Non-operating 50g
Vibration	IEC 60068-2-6 (Test Fc, Operating): 5g @ 10-500Hz
Emissions	CISPR 11: Group 1, Class A
ESD Immunity	IEC 61000-4-2: 6kV contact discharges 8kV air discharges
Radiated RF Immunity	IEC 61000-4-3: 10V/m with 1kHz sine-wave 80%AM from 30MHz to 1000MHz 10V/m with 200Hz 50% Pulse 100%AM at 900Mhz
EFT/B Immunity	IEC 61000-4-4: ±2kV at 5kHz on communications ports
Surge Transient Immunity	IEC 61000-4-5: ±2kV line-earth (CM) on shielded ports
Conducted RF Immunity	IEC 61000-4-6: 10Vrms with 1kHz sine-wave 80%AM from 150kHz to 80MHz

Enclosure Type Rating	None (open-style)	
Conductors Wiring Category	802.3 compliant - twisted pair 2 ⁽¹⁾	
Certifications: (when product is marked)	UL	UL Listed Industrial Control Equipment
	CSA	CSA Certified Process Control Equipment for Class I, Division 2 Group A,B,C,D Hazardous Locations
	CSA FM	CSA Certified Process Control Equipment FM Approved Equipment for use in Class I Division 2 Group A,B,C,D Hazardous Locations
	CE ⁽²⁾	European Union 89/336/EEC EMC Directive, compliant with: EN 50082-2; Industrial Immunity EN 61326; Meas./Control/Lab., Industrial Requirements EN 61000-6-2; Industrial Immunity EN 61000-6-4; Industrial Emissions
	C-Tick ⁽²⁾	Australian Radiocommunications Act, compliant with: AS/NZS 2064; Industrial Emissions
	EEx ⁽²⁾	European Union 94/9/EC ATEX Directive, compliant with: EN 50021; Potentially Explosive Atmospheres, Protection "n"
	ODVA	ODVA conformance tested to ODVA EtherNet/IP specifications

⁽¹⁾ For information on conductor routing, refer to publications 1770-4.1, Industrial Automation Wiring and Grounding Guidelines, and ENET-IN001, EtherNet/IP Media Planning and Installation Manual.

⁽²⁾ See the Product Certification link at www.ab.com for Declarations of Conformity, Certificates, and other certification details.

IMPORTANT

This equipment is not resistant to sunlight or other sources of UV radiation.

The secondary of a current transformer shall not be open-circuited when applied in Class I, Zone 2 environments.

Equipment of lesser Enclosure Type Rating must be installed in an enclosure providing at least IP54 protection when applied in Class I, Zone 2 environments.

This equipment shall be used within its specified ratings defined by Allen-Bradley.

Provision shall be made to prevent the rated voltage from being exceeded by transient disturbances of more than 40% when applied in Class I, Zone 2 environments.

Allen-Bradley and ControlLogix are trademarks of Rockwell Automation.
Ethernet is a trademark of Digital Equipment Corporation, Intel, and Xerox Corporation.

www.rockwellautomation.com

Power, Control and Information Solutions Headquarters

Americas: Rockwell Automation, 1201 South Second Street, Milwaukee, WI 53204-2496 USA, Tel: (1) 414.382.2000, Fax: (1) 414.382.4444

Europe/Middle East/Africa: Rockwell Automation, Vorstlaan/Boulevard du Souverain 36, 1170 Brussels, Belgium, Tel: (32) 2 663 0600, Fax: (32) 2 663 0640

Asia Pacific: Rockwell Automation, Level 14, Core F, Cyberport 3, 100 Cyberport Road, Hong Kong, Tel: (852) 2887 4788, Fax: (852) 2508 1846

Publication 1756-IN053D-EN-P - June 2002

PN 957689-13

Supersedes Publication 1756-IN053C-EN-P - May 2001

Copyright © 2002 Rockwell Automation, Inc. All rights reserved. Printed in the U.S.A.