

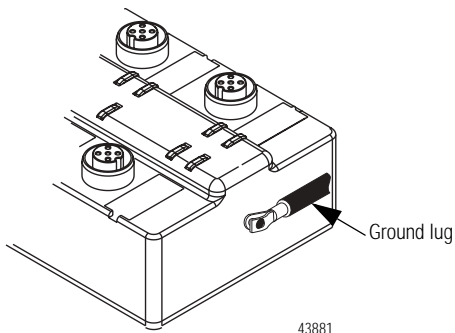

Installation Instructions

ArmorBlock MaXum 12 Input/ 4 Output Module With Ground Lug

Cat. No. 1792D-12BT4PE



This ArmorBlock MaXum™ I/O module (Cat. No. 1792D-12BT4PE) is a stand-alone 24V dc I/O product, which communicates via a DeviceNet™ network. The sealed housing of this module requires no enclosure.

This module has 12 inputs and 4 outputs accessed through Y splitter cables. Inputs are 24V dc devices. Four self-protected 24V dc outputs can provide up to 2.0 amp each. Diagnostic features are short circuit, open wire and no load detection reported to the connector level for inputs and to point level for outputs. Local logic control has been included.

An external lug exists to ground the block.

Important User Information

Solid state equipment has operational characteristics differing from those of electromechanical equipment. *Safety Guidelines for the Application, Installation and Maintenance of Solid State Controls* (Publication SGI-1.1 available from your local Rockwell Automation sales office or online at <http://www.ab.com/manuals/gi>) describes some important differences between solid state equipment and hard-wired electromechanical devices. Because of this difference, and also because of the wide variety of uses for solid state equipment, all persons responsible for applying this equipment must satisfy themselves that each intended application of this equipment is acceptable.





In no event will Rockwell Automation, Inc. be responsible or liable for indirect or consequential damages resulting from the use or application of this equipment.

The examples and diagrams in this manual are included solely for illustrative purposes. Because of the many variables and requirements associated with any particular installation, Rockwell Automation, Inc. cannot assume responsibility or liability for actual use based on the examples and diagrams.

No patent liability is assumed by Rockwell Automation, Inc. with respect to use of information, circuits, equipment, or software described in this manual.

Reproduction of the contents of this manual, in whole or in part, without written permission of Rockwell Automation, Inc. is prohibited.

Throughout this manual, when necessary we use notes to make you aware of safety considerations.

 WARNING	Identifies information about practices or circumstances that can cause an explosion in a hazardous environment, which may lead to personal injury or death, property damage, or economic loss.
IMPORTANT	Identifies information that is critical for successful application and understanding of the product.
 ATTENTION	Identifies information about practices or circumstances that can lead to personal injury or death, property damage, or economic loss. Attentions help you: <ul style="list-style-type: none">• identify a hazard• avoid a hazard• recognize the consequence
 SHOCK HAZARD	Labels may be located on or inside the equipment (e.g., drive or motor) to alert people that dangerous voltage may be present.
 BURN HAZARD	Labels may be located on or inside the equipment (e.g., drive or motor) to alert people that surfaces may be dangerous temperatures.

ATTENTION**Environment and Enclosure**

This equipment is intended for use in a Pollution Degree 2 industrial environment, in overvoltage Category II applications (as defined in IEC publication 60664-1), at altitudes up to 2000 meters without derating.

This equipment is considered Group 1, Class A industrial equipment according to IEC/CISPR Publication 11. Without appropriate precautions, there may be potential difficulties ensuring electromagnetic compatibility in other environments due to conducted as well as radiated disturbance.

This equipment is supplied as "open type" equipment. It must be mounted within an enclosure that is suitably designed for those specific environmental conditions that will be present and appropriately designed to prevent personal injury resulting from accessibility to live parts. The interior of the enclosure must be accessible only by the use of a tool. Subsequent sections of this publication may contain additional information regarding specific enclosure type ratings that are required to comply with certain product safety certifications.

NOTE: See NEMA Standards publication 250 and IEC publication 60529, as applicable, for explanations of the degrees of protection provided by different types of enclosure. Also, see the appropriate sections in this publication, as well as the Allen-Bradley publication 1770-4.1 ("Industrial Automation Wiring and Grounding Guidelines"), for additional installation requirements pertaining to this equipment.

Package Contents

Your package contains:

- 1 ArmorBlock MaXum module
- these installation instructions

(Note: Cable bases are ordered and shipped separately.)

Install Your ArmorBlock MaXum I/O Module

To install the module you must:

- Set the node address
- Mount the module to the cable base
- Connect the input/output cord sets to the MaXum module
- Communicate with your ArmorBlock MaXum I/O module

Each of these steps is explained in the following procedures.

ATTENTION



Preventing Electrostatic Discharge

This equipment is sensitive to electrostatic discharge, which can cause internal damage and affect normal operation. Follow these guidelines when you handle this equipment:

- Touch a grounded object to discharge potential static.
 - Wear an approved grounding wriststrap.
 - Do not touch connectors or pins on component boards.
 - Do not touch circuit components inside the equipment.
 - If available, use a static-safe workstation.
 - When not in use, store the equipment in appropriate static-safe packaging.
-

Set the Node Address

Valid node addresses are **00** through **63**.

Set the node address using the rotary switches, RSNetWorx for DeviceNet™, or another software configuration tools. Setting the switches to a number from **64** through **99** lets the software have address control.

Each module is shipped set for node address **63**. The switches are located on the underside of the module. The two switches are:

- MSD (most significant digit)
- LSD (least significant digit)

To reset the node address, use a small blade screwdriver to rotate the switches. Line up the small black dot on the switch with the number setting you wish to use.

The rotary switches are read at module power up only. Settings from 64 through 99 cause the module to use the last valid node address stored internally. For example, the last setting was 40. If a change is made to 68, and then you power up, the address will default to 40.

Refer to the following illustration of the node address.

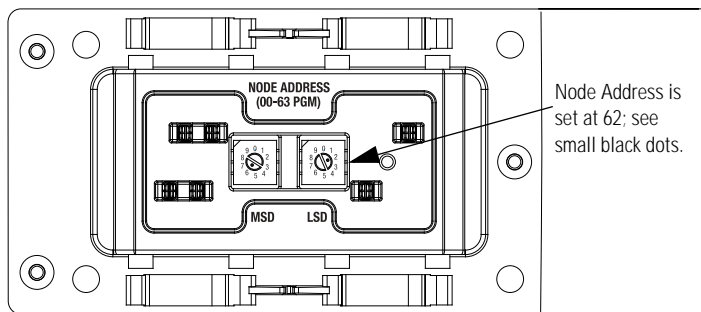

Bottom View of Module

41462

The module is equipped with AutoBaud detect. AutoBaud lets the module read the settings already in use on your DeviceNet network and automatically adjusts to follow those settings.

Mount the Module to the Cable Base

This module mounts to the following cable bases:

- 1792D-CBFM for KwikLink™ flat media installation
- 1792D-CB12 for 12mm drop cable installation
- 1792D-CB18P for round media DeviceNet and output power
- other optional cable base assembly

IMPORTANT

The cable base should already be installed. For more information about the cable base, see publication 1792D-IN036 (CB18P) or 1792D-IN009 (CBFM, CB12).

6 ArmorBlock MaXum 12 Input/ 4 Output Module With Ground Lug

To install the module:

IMPORTANT

Proper alignment of the screws is necessary to complete the connections between the module contacts and the cable contacts.

1. Position the module over the mounted cable base. Align the three captive screws in the module with the accepting receptacles in the base.
2. Tighten the screws with a torque of 8 inch-pounds to secure the module to the base.

Note: Dimensions change according to the cable base and module combination used.

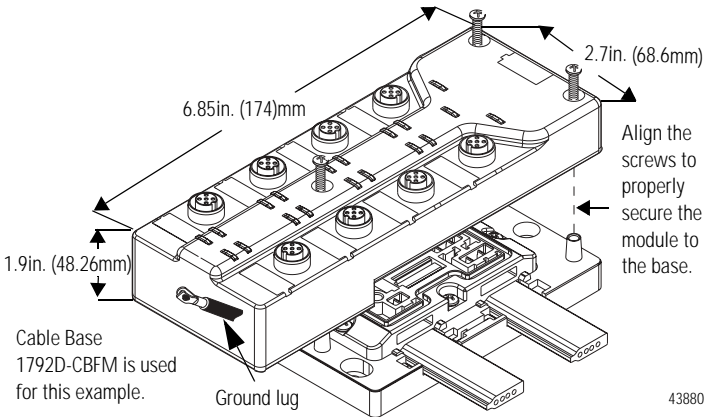

WARNING



When used in a Class I, Division 2, hazardous location, this equipment must be mounted in a suitable enclosure with proper wiring method that complies with the governing electrical codes.

Connect the Input / Output Cord Sets to the MaXum Module

This module uses 5 pin micro (12mm) style PCB mounted connectors.

Eight micro caps cover the connectors on your module. Remove the caps and connect your cord sets to the appropriate ports. This product has two inputs or outputs per I/O connector. Use a “Y” splitter cable for access to all I/O connections.

Use the micro caps to cover and seal unused ports. Pinout diagrams for the connectors are shown below.

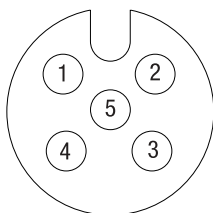

Input Micro-Connector

(view into socket)

Pin 1 Sensor Source voltage

Pin 2 Input B

Pin 3 Return Logic Ground¹

Pin 4 Input A

Pin 5 PE

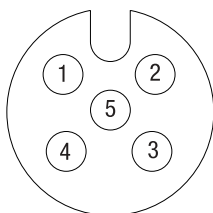

Output Micro-Connector

(view into socket)

Pin 1 Not Used

Pin 2 Output B

Pin 3 Auxiliary Power Ground

Pin 4 Output A

Pin 5 PE

41452

¹Logic Ground is approximately 0.4V above DeviceNet V- measured at the module.

Molded I/O cables with LEDs embedded in the connector are incompatible with MaXum universal sink/source inputs.

WARNING



If you connect or disconnect the communications cable with power applied to this module or any device on the network, an electrical arc can occur. This could cause an explosion in hazardous location installations.

Refer to publication 889-5.0 for Rockwell Automation cables and cord sets offerings.

WARNING



Use supply wires suitable for 30°C above surrounding ambient.

IMPORTANT

If the devices (sensors) connected to the input connections require Class 2 power to operate, the DeviceNet connections of this equipment must be powered by a Class 2 source.

ATTENTION



- Make sure all connectors and caps are securely tightened to properly seal the connections against leaks and maintain IP67 requirements.
 - For maximum noise immunity, input and output cable return wires must be properly terminated. When inputs and outputs are connected in loopback, return wires should be connected together.
 - I/O cable length should be less than 30 meters.
-

I/O connectors for this module are shown below.

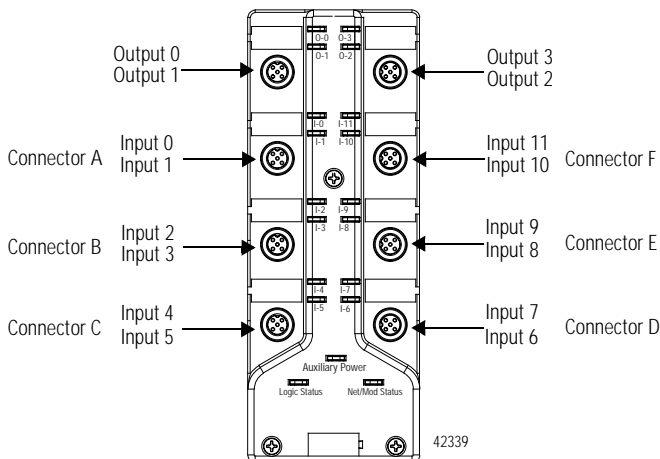

WARNING



If you connect or disconnect wiring while the field-side power is on, an electrical arc can occur. This could cause an explosion in hazardous location installations. Be sure that power is removed or the area is nonhazardous before proceeding.

Output Power and DeviceNet Cables

Output power and DeviceNet cables are described in the installation publications for the cable base assembly of your choice. Refer to the following publications:

- 1792D-IN009 ArmorBlock MaXum Cable Base Installation Instructions
- DN-6.7.2 DeviceNet Cable Planning and Installation Manual

Communicate With Your ArmorBlock MaXum I/O Module

This ArmorBlock module's I/O is exchanged with the master through a cyclic, poll, or change-of-state connection.

The module consumes and produces I/O data as follows:

Type of I/O Connections	Consumes	Produces
Cyclic	1 Byte	4 Bytes
Polled	1 Byte	4 Bytes
Change-of-State	1 Byte	4 Bytes

Cyclic - allows configuration of the block as an I/O client. The block will produce and consume its I/O cyclically at the rate configured.

Polled - a master initiates communication by sending its polled I/O message to the module. The 12 input / 4 output module consumes the message, updates outputs, and produces a response. The response has input data, input faults, output faults, and the status of the auxiliary power.

Change-of-State - productions occur when an input changes or a fault condition occurs. If no input or fault condition change occurs within the expected packet rate, a heartbeat production occurs. This heartbeat production tells the scanner module that the I/O module is alive and ready to communicate. Consumption occurs when data changes and the master produces new output data to the I/O block.

Refer to the table below for the word/bit definitions.

Bit	07	06	05	04	03	02	01	00
Produces 0	I7	I6	I5	I4	I3	I2	I1	I0
Produces 1	ISC-D	ISC-C	ISC-B	ISC-A	I11	I10	I9	I8
Produces 2	OW-F	OW-E	OW-D	OW-C	OW-B	OW-A	ISC-F	ISC-E
Produces 3	RSVD	OPWR	RSVD	RSVD	OFLT3	OFLT2	OFLT1	OFLT0
Consumes 0	RSVD	RSVD	RSVD	RSVD	O3	O2	O1	O0

Where: I = Input, ISC = Input Short Circuit in Sensor Source Voltage, OW = Off Wire, RSVD = Reserved, OPWR = Output Power (auxiliary power), OFLT = Output fault, O = Output

The DevicLogix Product assembly for the 1792D-8BT8DPE is as follows:

Bit	07	06	05	04	03	02	01	00
Produces 0	I7	I6	I5	I4	I3	I2	I1	I0
Produces 1	ISC-D	ISC-C	ISC-B	ISC-A	I11	I10	I9	I8
Produces 2	OW-F	OW-E	OW-D	OW-C	OW-B	OW-A	ISC-F	ISC-E
Produces 3		OPWR	Logic Ena					
Produces 4					O3	O2	O1	O0
Produces 5	PNB7	PNB6	PNB5	PNB4	PNB3	PNB2	PNB1	PNB0

Where: I = Input, ISC=Input Short Circuit in Sensor Source Voltage, OW = Off Wire, OPWR= Output Power (auxiliary power), Logic Ena = DeviceLogix enabled, O = Output, PNB = Produced Network Bit (Network Output)

12 ArmorBlock MaXum 12 Input/ 4 Output Module With Ground Lug

Byte	Bit	Description
Produces 0	00-07	Input Status bits: When the bit is set (1), the input is on. Bit 00 = input 0, bit 01 = input 1, bit 02 = input 2, and so on to bit 07 = input 7.
Produces 1	00-03 04-07	Input Status bits: When the bit is set (1), the input is on. Bit 08 = input 8, bit 09 = input 9, bit 010 = input 10, bit 011 = input 11. Input short circuit fault (ISC): ISC-A indicates a short circuit fault for connector A. Input short circuit fault (ISC): ISC-B indicates a short circuit fault for connector B. Input short circuit fault (ISC): ISC-C indicates a short circuit fault for connector C. Input short circuit fault (ISC): ISC-D indicates a short circuit fault for connector D.
Produces 2	00-01 02-07	Input short circuit fault (ISC): ISC-E indicates a short circuit fault for connector E. Input short circuit fault (ISC): ISC-F indicates a short circuit fault for connector F. Input off wire fault (OW): OW-A indicates an off-wire fault for connector A. Input off wire fault (OW): OW-B indicates an off-wire fault for connector B. Input off wire fault (OW): OW-C indicates an off-wire fault for connector C. Input off wire fault (OW): OW-D indicates an off-wire fault for connector D. Input off wire fault (OW): OW-E indicates an off-wire fault for connector E. Input off wire fault (OW): OW-F indicates an off-wire fault for connector F.
Produces 3	00-03 06 04, 05, 07	Output no load or overload fault (OFLT): - When the bit is set (1) an output fault has occurred. OFLT0 corresponds to output 0, OFLT1 corresponds to output 1, OFLT2 corresponds to output 2, OFLT3 corresponds to output 3 Output Power Fault (OPWR): When the bit is set (1) auxiliary power is not present. RSVD = Reserved
Consumes 0	00-03 04-07	Output bits: When the bit is set (1), the output will be turned on. Bit 00 corresponds to output 00, bit 01 corresponds to output 01, bit 02 to output 02, bit 03 to output 03. RSVD = Reserved

The DeviceNet Network uses advanced network technology, producer/consumer communication, to increase network functionality and throughput. Visit our web site at <http://www.ab.com/networks> for producer/consumer technology information and updates.

Troubleshoot With the Indicators

This module has the following indicators:

- Network/Module status indicator
- Logic status indicator
- Auxiliary power indicator
- Individual I/O status indicators for outputs 0 through 3 and inputs 0 through 11

Refer to the following table for point indicators.

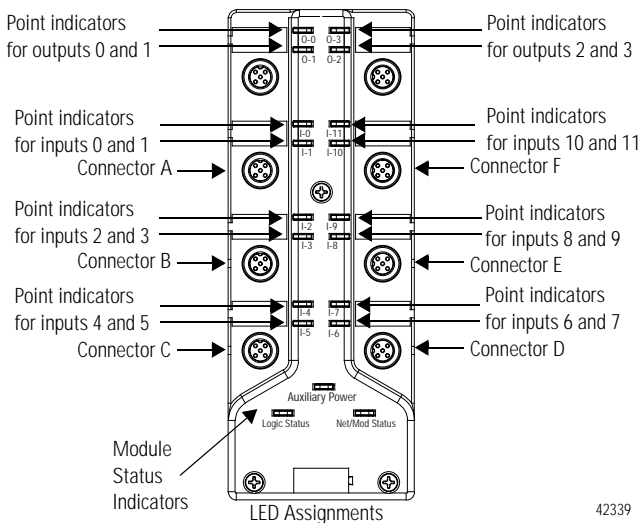

42339

The following table describes the network and module status indicator.

Net/Mod Status Indicator	
Indicator	Status
Off	No power or auto bauding
Flashing Green/Off	On line but not connected
Solid Green	On line, link OK, connected
Flashing Red	Recoverable fault - module configuration error
	I/O connection fault - one or more I/O connections in the timed-out state
Solid Red	Unrecoverable fault
	Communication failure - duplicate node address present or incorrect baud rate
Green to Red to Off	At powerup only - LED test

The following table describes the logic status indicator.

Logic Status Indicator	
Indicator	Status
Off	Logic is disabled
Solid Green	Logic is enabled
Flashing Green	Local forces are applied and local logic is enabled

The following table describes the auxiliary status indicator.

Auxiliary Status Indicator	
Indicator	Status
None	No auxiliary power
Solid Green	Auxiliary power present

The following table describes individual I/O status indicators.

I/O Status Indicators			
Function	Module Status Indicator	Point Indicator¹	Status
Outputs	Green	None	Output not energized
	Green	Yellow	Output energized
	Module Status blink red	Orange	Output shorted - auto restart
	Module Status blink red	Red	Output shorted - latching
	Module Status blink red	Orange	Output no load - auto restart
Inputs	Green	Red	Output no load - latching
	Green	None	No valid input
	Module Status blink red	Yellow	Valid input
	Module Status blink red	Red	Short on input connection ¹
	Module Status blink red	Blink red	Off wire on input connection ¹

¹ Only the first LED of each input connector will light as red when twin inputs are used.

Specifications

12 Input / 4 Output Module - Cat. No. 1792D-12BT4PE		
Input Specifications	Maximum	Minimum
Inputs per block 12 - 3 wire or dry contact PNP devices or 6 - 4 wire PNP devices		
Sensor Source Current (per input)	See the graph located after this Specifications table.	
Off-wire Sense Current	0.5mA	-
On-state Voltage	25V dc	10V dc
On-state Current	10mA	2mA
Off-state Voltage	5V dc	-
Off-state Current	-	1.5mA
Output Specifications	Maximum	Minimum
Outputs per block 4 sourcing outputs labeled O0 through O3		
Off Peak Blocking Voltage	30V	10V
On-state Voltage Drop	1V	-
On-state Current	2.0A	-
Off-state Leakage	1.5mA	-
Module Current (all outputs)	4.0A	-

16 ArmorBlock MaXum 12 Input/ 4 Output Module With Ground Lug

12 Input / 4 Output Module - Cat. No. 1792D-12BT4PE		
Output Specifications (cont.)	Maximum	Minimum
Surge Current - for 10ms, repeatable every 2s	4.0A	-
No Load Sense Current (On-state)	0.18A	-
General Specifications	Maximum	Minimum
DeviceNet Power Voltage Current Refer to the graphs in the DeviceNet Power Supply Requirements section of the ArmorBlock MaXum I/O and ArmorBlock I/O Selection Guide, pub. no. 1792-SG001.	25V dc max 175mA max (no sensors)	11V dc min up to 1.6A (12 sensors @ 50mA per sensor)
Auxiliary Power Voltage Current	30V dc max 4A max	10V dc min 4A max
Indicators	Net/Mod Status - red/green Logic Status - green Auxiliary Power - green Point LED - yellow/orange/red	
Communication Rate	<ul style="list-style-type: none"> • 125Kbps @ 500 meters(1600 feet) for thick cable, flat media length 375 meters (1230 feet) • 250Kbps @ 200 meters(600 feet) for thick cable, flat media length 150 meters (492 feet) • 500Kbps @ 100 meters (330 feet) for thick cable, flat media length 75 meters (246 feet) 	
Dimensions (assembled to base) inches - (Millimeters)	1.9H x 2.7W x 6.9D (48)H x (69)W x (174)D	
Operational Temperature	IEC 60068-2-1 (Test Ad, Operating Cold), IEC 60068-2-2 (Test Bd, Operating Dry Heat), IEC 60068-2-14 (Test Nb, Operating Thermal Shock): -25 to 60 ° (-13 to 140 °F)	
Storage Temperature	IEC 60068-2-1 (Test Ab, Un-packaged Non-operating Cold), IEC 60068-2-2 (Test Bb, Un-packaged Non-operating Dry Heat), IEC 60068-2-14 (Test Na, Un-packaged Non-operating Thermal Shock): -25 to 80 °C (-13 to 176 °F)	
Relative Humidity	IEC 60068-2-30 (Test Db, Un-packaged Non-operating Damp Heat): 5 to 100% non-condensing	
Vibration	IEC 60068-2-6 (Test Fc, Operating): 10g @ 10-500 Hz	
Operating Shock	IEC 60068-2-27 (Test Ea, Unpackaged Shock): 30g	
Non-Operating Shock	IEC 60068-2-27 (Test Ea, Unpackaged Shock): 50g	

12 Input / 4 Output Module - Cat. No. 1792D-12BT4PE**General Specifications (continued)**

Emissions	CISPR 11: Group 1, Class A
ESD Immunity	IEC 61000-4-2: 6kV contact discharges 8kV air discharges
Radiated RF Immunity	IEC 61000-4-3: 10V/m with 1kHz sine-wave 80%AM from 30MHz to 2000MHz 10V/m with 200Hz 50% Pulse 100%AM at 900MHz 10V/m with 200Hz 50% Pulse 100%AM at 1890MHz
EFT/B Immunity	IEC 61000-4-4: ±2kV at 5kHz on power ports ±2kV at 5kHz on signal ports ±2kV at 5kHz on communications ports
Surge Transient Immunity	IEC 61000-4-5: ±1kV line-line(DM) and ±2 line-earth(CM) on power ports ±1kV line-line(DM) and ±2kV line-earth(CM) on signal ports ±2kV line-earth(CM) on communications ports
Conducted RF Immunity	IEC 61000-4-6: 10Vrms with 1kHz sine-wave 80%AM from 150kHz to 80MHz
Conductors	Publication DN-6.7.2
Enclosure	Meets IP67
Supply Voltages/Voltage Ranges	DNet Power: 11V dc to 25V dc; Auxiliary Power: 10V dc to 30V dc
Supply Power/Current Ratings	DNet current: 1.6A; Input current: 50mA; Output power: 60VA DC-13/SQ; Outputs 4A total; Auxiliary current: 4A
Isolation voltage (continuous-voltage withstand rating)	Tested to withstand 750V dc for 60 seconds
Wire Size	Use 14-22 AWG wire with insulation temperature rating of 75°C min. See Publication DN-6.7.2; Category: 2.
Wiring Category ¹	2 - on signal ports 2 - on power ports 2 - on communications ports

18 ArmorBlock MaXum 12 Input/ 4 Output Module With Ground Lug

12 Input / 4 Output Module - Cat. No. 1792D-12BT4PE

General Specifications (continued)

Certifications: ² (when product is marked)	CSA	CSA Certified Process Control Equipment
	CSA	CSA Certified Process Control Equipment for Class I, Division 2 Group A,B,C,D Hazardous Locations
	CE	European Union 89/336/EEC EMC Directive, compliant with: EN 50082-2; Industrial Immunity EN 61326: Meas./Control/Lab., Industrial Requirements EN 61000-6-2; Industrial Immunity EN 61000-6-4; Industrial Emissions EN 61131-2; Programmable Controllers (Clause 8, Zone A & B)
	C-Tick	Australian Radiocommunications Act, compliant with: AS/NZS CISPR 11; Industrial Emissions
	ODVA	ODVA conformance tested to DeviceNet specifications

1. Use this Conductor Category information for planning conductor routing. Refer to Publication 1770-4.1, "Industrial Automation Wiring and Grounding Guidelines".
2. See the Product Certification link at www.ab.com for Declarations of Conformity, Certificates, and other certification details.

Sensor Source Current - Amp

Note: This is an illustration of total current for all 12 inputs. Divide by 12 for current per input.

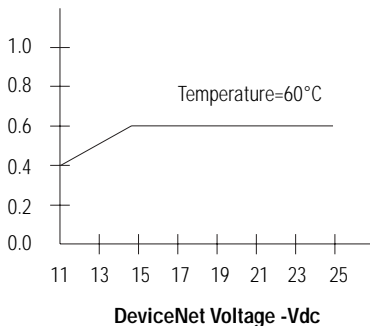



42574

ArmorBlock, ArmorBlock MaXum, RSNetWorx for DeviceNet, and KwikLink are trademarks of Rockwell Automation.

DeviceNet is a trademark of Open DeviceNet Vendor Association (ODVA).

North American Hazardous Location Approval

The following information applies when operating this equipment in hazardous locations:	Informations sur l'utilisation de cet équipement en environnements dangereux:
<p>Products marked "CL I, DIV 2, GP A, B, C, D" are suitable for use in Class I Division 2 Groups A, B, C, D, Hazardous Locations and nonhazardous locations only. Each product is supplied with markings on the rating nameplate indicating the hazardous location temperature code. When combining products within a system, the most adverse temperature code (lowest "T" number) may be used to help determine the overall temperature code of the system. Combinations of equipment in your system are subject to investigation by the local Authority Having Jurisdiction at the time of installation.</p>	<p>Les produits marqués "CL I, DIV 2, GP A, B, C, D" ne conviennent qu'à une utilisation en environnements de Classe I Division 2 Groupes A, B, C, D dangereux et non dangereux. Chaque produit est livré avec des marquages sur sa plaque d'identification qui indiquent le code de température pour les environnements dangereux. Lorsque plusieurs produits sont combinés dans un système, le code de température le plus défavorable (code de température le plus faible) peut être utilisé pour déterminer le code de température global du système. Les combinaisons d'équipements dans le système sont sujettes à inspection par les autorités locales qualifiées au moment de l'installation.</p>
<div style="display: flex; align-items: center;"> <div style="margin-right: 10px;"> <p>WARNING</p>  </div> <div> <ul style="list-style-type: none"> • Do not disconnect equipment unless power has been removed or the area is known to be nonhazardous. • Do not disconnect connections to this equipment unless power has been removed or the area is known to be nonhazardous. Secure any external connections that mate to this equipment by using screws, sliding latches, threaded connectors, or other means provided with this product. • Substitution of components may impair suitability for Class I, Division 2. • If this product contains batteries, they must only be changed in an area known to be nonhazardous. </div> </div>	<div style="display: flex; align-items: center;"> <div style="margin-right: 10px;"> <p>AVERTISSEMENT</p>  </div> <div> <ul style="list-style-type: none"> • Couper le courant ou s'assurer que l'environnement est classé non dangereux avant de débrancher l'équipement. • Couper le courant ou s'assurer que l'environnement est classé non dangereux avant de débrancher les connecteurs. Fixer tous les connecteurs externes reliés à cet équipement à l'aide de vis, loquets coulissants, connecteurs filetés ou autres moyens fournis avec ce produit. • La substitution de composants peut rendre cet équipement inadapté à une utilisation en environnement de Classe I, Division 2. • S'assurer que l'environnement est classé non dangereux avant de changer les piles. </div> </div>

This product has been tested at an Open DeviceNet Vendor Association, Inc. (ODVA) authorized independent test laboratory and found to comply with ODVA Conformance Test. Please contact the ODVA web site (<http://www.odva.org>) for listing of products tested by ODVA independent test labs for further details.

Rockwell Automation Support

Rockwell Automation provides technical information on the web to assist you in using its products. At <http://support.rockwellautomation.com>, you can find technical manuals, a knowledge base of FAQs, technical and application notes, sample code and links to software service packs, and a MySupport feature that you can customize to make the best use of these tools.

For an additional level of technical phone support for installation, configuration and troubleshooting, we offer TechConnect Support programs. For more information, contact your local distributor or Rockwell Automation representative, or visit <http://support.rockwellautomation.com>.

Installation Assistance

If you experience a problem with a hardware module within the first 24 hours of installation, please review the information that's contained in this manual. You can also contact a special Customer Support number for initial help in getting your module up and running:

United States	1.440.646.3223 Monday – Friday, 8am – 5pm EST
Outside United States	Please contact your local Rockwell Automation representative for any technical support issues.

New Product Satisfaction Return

Rockwell tests all of its products to ensure that they are fully operational when shipped from the manufacturing facility. However, if your product is not functioning and needs to be returned:

United States	Contact your distributor. You must provide a Customer Support case number (see phone number above to obtain one) to your distributor in order to complete the return process.
Outside United States	Please contact your local Rockwell Automation representative for return procedure.

www.rockwellautomation.com

Power, Control and Information Solutions Headquarters

Americas: Rockwell Automation, 1201 South Second Street, Milwaukee, WI 53204-2496 USA, Tel: (1) 414.382.2000, Fax: (1) 414.382.4444

Europe/Middle East/Africa: Rockwell Automation, Vorstlaan/Boulevard du Souverain 36, 1170 Brussels, Belgium, Tel: (32) 2 663 0600, Fax: (32) 2 663 0640

Asia Pacific: Rockwell Automation, Level 14, Core F, Cyberport 3, 100 Cyberport Road, Hong Kong, Tel: (852) 2887 4788, Fax: (852) 2508 1846

Publication 1792D-IN056A-EN-P - October 2004

PN 957928-11

Copyright © 2004 Rockwell Automation, Inc. All rights reserved. Printed in the U.S.A.