

Wiring and Grounding Guidelines for PanelView Plus Terminals

Topic	Page
Terms and Definitions	2
Wiring and Safety Guidelines	3
Hazardous Location Advisory	3
Remove and Install the Power Terminal Block	4
PanelView Plus Nonisolated DC Terminals	6
PanelView Plus Isolated DC Terminals	11
PanelView Plus AC Terminals	16
Communication Port Isolation	20
Ethernet Cable	21
Guidelines for Powering Nonisolated DC PanelView Plus Terminals	22
Guidelines for Powering the Isolated DC PanelView Plus Terminals	25
How to Avoid Grounding Problems	26
Additional Resources	31

About This Publication

This document provides information on how to properly wire, ground, and apply power to these devices:

- PanelView™ Plus 6 terminals (700...1500)
- PanelView Plus 700...1500 terminals supporting FactoryTalk® View Machine Edition software, version 5.1 or earlier
- PanelView Plus 400 and 600 terminals
- PanelView Plus Compact terminals (400, 600, and 1000)

Throughout this publication, PanelView Plus terminal is used generically to refer to all terminals unless specifically stated.



Terms and Definitions

This section provides a list of important terms and definitions referred to in this document.

UL Class 2 - A UL Class 2 power supply meets the requirements of UL 1310, Class 2 Power Units. A Class 2 power source has a 'Class 2' marking and UL symbol on its nameplate. Such a supply, when properly applied, provides output power that is safe from electrical shock and fire hazard.

Safety Extra-low Voltage (SELV) - An electrical secondary circuit in which the voltage cannot exceed a safe value under normal and single-fault conditions, including earth faults in other circuits. SELV is defined in IEC EN60950 and IEC EN60364-4-41.

The voltage between any two conductors in a SELV circuit, and the voltage between any conductor and earth, cannot exceed 30V rms, 42.4V AC peak, or 60V DC under normal operating or single-fault conditions.

SELV Power Source - A power source determined by a regulatory body to meet SELV requirements.

Protective Extra-low Voltage (PELV) - A safety extra-low voltage output with its common connected to earth ground.

Earth/Ground - A conducting path between an electric circuit or equipment and ground for safety or EMC reduction. In industrial equipment, the earth connection is typically a grounded metal bar with features to facilitate connecting to multiple pieces of equipment.

DC Common - For PanelView Plus terminals that operate on 24V DC power, DC common is the conductor that returns 24V DC current to the source supply, and is connected to the DC(-) position on the input power terminal block.

Functional Earth (FE) Conductor - A conductor that is in electrical contact with Earth for interference immunity improvement.

Protective Earth (PE) Conductor - A conductor that is in electrical contact with Earth for safety protection against electrical shock.

Ground Bus - The system ground bus is a metal bar in the enclosure whose purpose is to provide a grounding point for the equipment that comprises the system. The ground bus has multiple features to facilitate grounding multiple pieces of equipment. The ground bus is connected to the grounding electrode system via the grounding electrode conductor.

In typical industrial systems, the ground bus is mounted on the back panel of the enclosure. The protective earth and functional earth terminals of the various equipment in the enclosure are connected to the ground bus bar.

Wiring and Safety Guidelines

Use publication NFPA 70E, Electrical Safety Requirements for Employee Workplaces, IEC 60364 Electrical Installations in Buildings, or other applicable wiring safety requirements for the country of installation when wiring the devices. In addition to the NFPA guidelines, follow these guidelines:

- Connect the device and other similar electronic equipment to its own branch circuit.
- Protect the input power by a fuse or circuit breaker rated at no more than 15 A.
- Route incoming power to the device by a separate path from the communication lines.
- Cross power and communication lines at right angles, if they must cross.

Communication lines can be installed in the same conduit as low-level DC I/O lines (less than 10V).

- Shield and ground cables appropriately to avoid electromagnetic interference (EMI).

Grounding minimizes noise from EMI and is a safety measure in electrical installations.

For more information on grounding recommendations, refer to the National Electrical Code published by the National Fire Protection Association.

Hazardous Location Advisory



WARNING: Explosion Hazard

- Substitution of components may impair suitability for hazardous locations.
 - Do not disconnect equipment unless power has been switched off and the area is known to be nonhazardous.
 - Do not connect or disconnect components unless power has been switched off.
 - All wiring must comply with N.E.C. articles 501, 502, 503, and C.E.C. section 18-1J2, as appropriate.
 - Peripheral equipment must be suitable for the location it is used in.
-

Remove and Install the Power Terminal Block

PanelView Plus terminals are shipped with the power terminal block installed. You can remove the terminal block for ease of installation, wiring, and maintenance.



WARNING: Explosion Hazard

Do not disconnect equipment unless power has been switched off and the area is known to be nonhazardous.

Disconnect all power before installing or replacing components. Failure to disconnect power may result in electrical shock or damage to the device.

PanelView Plus 400 and 600 Terminals

Follow these steps to remove the terminal block in any PanelView Plus 400 and 600 terminal, including the PanelView Plus Compact 400 and 600 terminals.

1. Insert the tip of a small screwdriver into the terminal block access slot.
2. Gently pry the terminal block away from the terminal to release the locking mechanism.

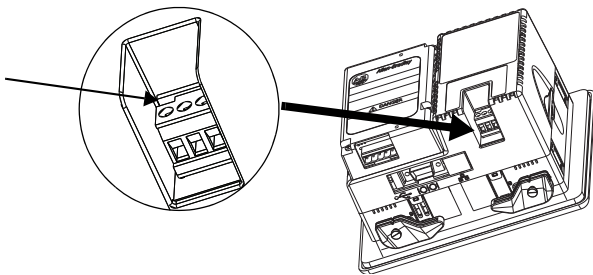

Follow these steps to replace the terminal block.

1. Press the terminal block base in first with the block leaning outward.

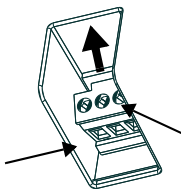

2. Gently push the top of the terminal block back to the vertical position to snap in the locking tab.

PanelView Plus 700...1500 Terminals

The terminal block installed in the 700...1500 terminals depends on the series of the logic module and the power input type.

Table 1 - Power Terminal Block

Power Input	This Terminal Block is Used	With This Device
DC	2-position	<ul style="list-style-type: none"> Series A or later PanelView Plus 6 logic modules Series E or later PanelView Plus logic modules⁽¹⁾ PanelView Plus Compact 1000 terminals
	3-position	<ul style="list-style-type: none"> Series A...D logic modules (PanelView Plus)⁽¹⁾
AC	3-position	<ul style="list-style-type: none"> All terminals and logic modules with an AC power input

(1) These logic modules support FactoryTalk View Machine Edition software, version 5.1 or earlier.

Follow these steps to remove the terminal block.

1. Loosen the two screws that secure the terminal block.
2. Gently pull the terminal block away from the connector.

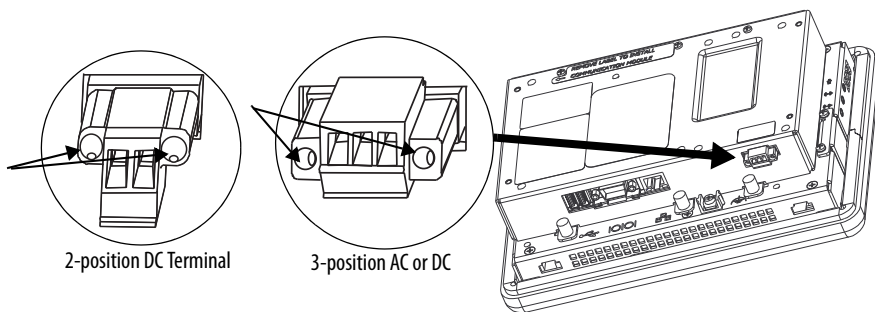

Follow these steps to install the terminal block.

1. Reattach the terminal block to the connector until seated.
2. Tighten the two screws that secure the terminal block to the connector.

PanelView Plus Nonisolated DC Terminals

PanelView Plus terminals with a nonisolated DC power input require both of these:

- Separate, external power supply for each device
- Functional earth/ground connection

Nonisolated DC Terminals

All PanelView Plus 400 and 600 terminals, and PanelView Plus Compact terminals that operate on DC power contain nonisolated, DC power supplies.

Table 2 - Terminals with Nonisolated DC Power Supplies

Cat. No.	Terminal Type
2711P-K4M5D, 2711P-K4M20D 2711P-K4C5D, 2711P-B4C5D 2711P-K4C20D, 2711P-B4C20D	PanelView Plus 400
2711P-K6M5D, 2711P-T6M5D, 2711P-B6M5D 2711P-K6C5D, 2711P-T6C5D, 2711P-B6C5D 2711P-K6M20D, 2711P-T6M20D, 2711P-B6M20D 2711P-K6C20D, 2711P-T6C20D, 2711P-B6C20D	PanelView Plus 600
2711PC-K4M20D, 2711PC-B4C20D, 2711PC-T6M20D, 2711PC-T6C20D, 2711PC-T10C4D1	PanelView Plus Compact 400, 600 and 1000

Nonisolated DC Logic Modules

Nonisolated, DC logic modules are used with PanelView Plus 700...1500 terminals supporting FactoryTalk View ME software, version 5.1 or earlier.

TIP All DC logic modules used by PanelView Plus 6 terminals are isolated.

Table 3 - Nonisolated DC Logic Modules

Cat. No. ⁽¹⁾	Logic Modules with Nonisolated DC Power
2711P-RP	Logic module without nonvolatile memory and RAM
2711P-RP1	Logic module with 64 MB nonvolatile memory and RAM
2711P-RP2	Logic module with 128 MB nonvolatile memory and RAM
2711P-RP6	CE logic module with 128 MB nonvolatile memory and RAM
2711P-RP2K	Conformal-coated logic module with 128 MB nonvolatile memory and RAM
2711P-RP6K	CE conformal-coated logic module with 128 MB nonvolatile memory and RAM
2711P-RP3	Logic module with 256 MB nonvolatile memory and RAM
2711P-RP7	CE logic module with 256 MB nonvolatile memory and RAM

(1) These logic modules support FactoryTalk View Machine Edition software, version 5.1 or earlier.

IMPORTANT Refer to [Communication Port Isolation on page 20](#) for information on communication port isolation.

External Power Supply for Nonisolated DC Terminals

Use a single, 24V DC power supply, such as catalog number 2711P-RSACDIN, to power PanelView Plus terminals with a nonisolated DC power supply. Using a separate, isolated, and ungrounded source with each terminal prevents ground loop currents from damaging the product.

The output on the power supply must be isolated from the input and not connected to the earth/ground.

The nonisolated power supply does not provide galvanic isolation. A Class 2 or safety extra-low voltage (SELV) isolated power supply with a 24V DC nominal output voltage is required to power the terminal.



ATTENTION: Use a Class 2 or SELV power supply as required by local wiring codes for your installation. The Class 2 and SELV power sources provide protection so that under normal and single-fault conditions, the voltage between conductors, and between the conductors and functional earth or protective earth, does not exceed a safe value.

Figure 1 - AC Power Supplies Powering Multiple PanelView Plus DC Terminals

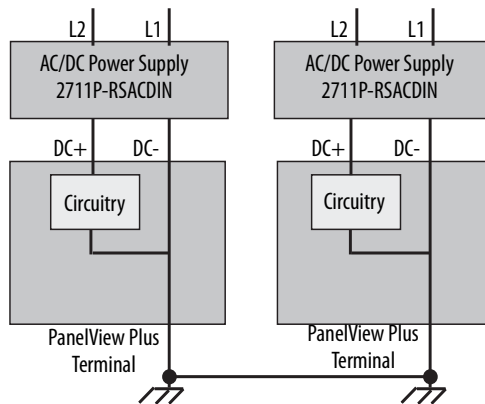

Earth/Ground Connection for Nonisolated DC Terminals



PanelView Plus devices with a nonisolated DC power supply have a functional earth/ground (FE) terminal that you must connect to a low-impedance earth/ground:

- The 700...1500 terminals have the functional earth/ground connection on the rear of the display module.
- The 400 and 600 terminals have the functional earth/ground connection on the power input terminal block.

IMPORTANT The functional earth connection to ground is mandatory. This connection is required for noise immunity, reliability, and Electromagnetic Compliance (EMC) with the European Union (EU) EMC Directive for CE-mark conformance.

The functional earth terminal wiring requires a minimum wire gauge.

Table 4 - Functional Earth Wiring

Terminal Model	FE Symbol	Wire Type		Wire Gauge	Terminal Screw Torque
400 and 600 ⁽¹⁾		Cu 90 °C (194 °F)	Copper (stranded or solid)	2.1...3.3 mm ² (14...12 AWG)	0.45...0.56 N·m (4...5 lb·in)
700...1500 ⁽²⁾	 GND			2.1...5.3 mm ² (14...10 AWG)	1.13...1.36 N·m (10...12 lb·in)

(1) Includes the PanelView Plus Compact 400 and 600 terminals.

(2) Includes the PanelView Plus Compact 1000 terminal.

On most PanelView Plus DC terminals, the earth/ground terminal is internally connected to the DC- terminal within the product.



ATTENTION: Damage or malfunction can occur when a voltage potential exists between two separate ground points. Make sure the PanelView Plus terminal does not serve as a conductive path between ground points at different potentials.

The functional earth terminal is typically connected to a system grounding bus. If the grounding bus has tapped holes, the conductor from the functional earth terminal must have a ground lug on the ground bus end. A bolt should pass through a star washer, then through the ground conductor lug, then into the ground bus.

Use the shortest, practical wire length to connect the functional earth/ground to a low-impedance earth/ground. The ground wire must be either green or green with a yellow stripe.

Refer to local wiring codes and regulations for grounding requirements.

Figure 2 - Functional Earth Connection for 700...1500 Nonisolated DC Terminals

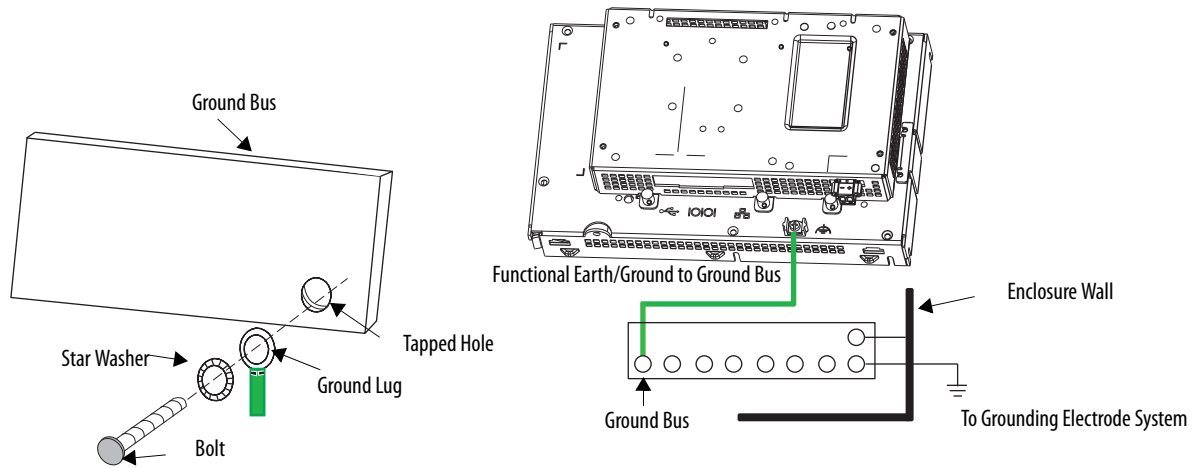
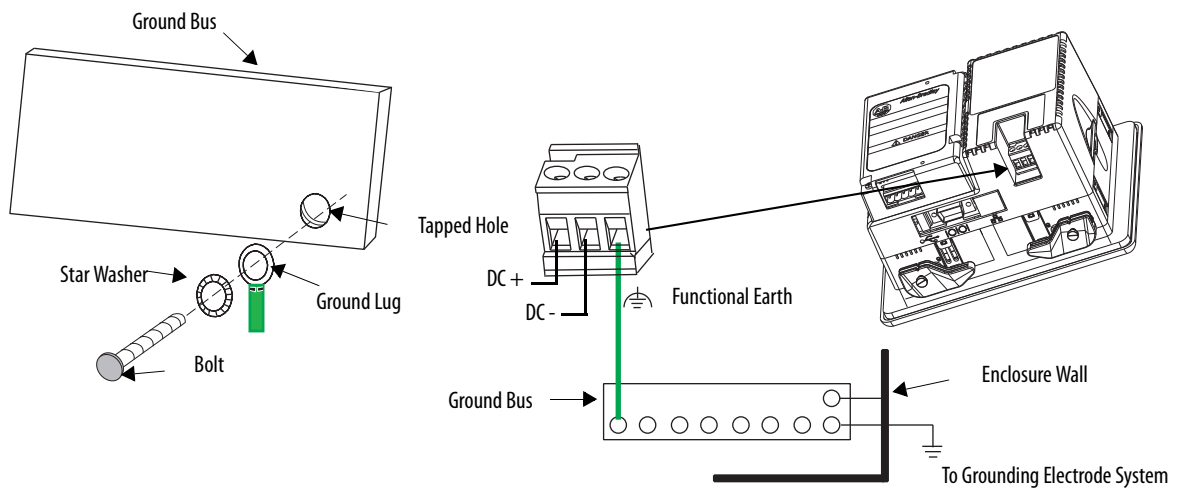

Figure 3 - Functional Earth Connection for 400 and 600 DC Terminals



AC-to-DC Power Supply to Power Nonisolated DC Terminals

Powering a PanelView Plus terminal with a nonisolated DC logic module from an AC power source requires an AC-to-DC power supply with a UL Class 2 or SELV output, or the 2711P-RSACDIN power supply.

Catalog number 2711P-RSACDIN is a UL accepted power supply for the PanelView Plus terminals. The power supply converts AC power to DC power, provides a SELV output, and has electrical input rating of 100...240V AC (50...60 Hz).

These are the electrical output ratings of the power supply:

- 24V DC nominal
- 3 A maximum

For more information on this power supply, refer to the AC Power Supply Installation Instructions, publication [2711P-IN005](#).

Figure 4 - Powering a Nonisolated DC Terminal from an AC Power Source

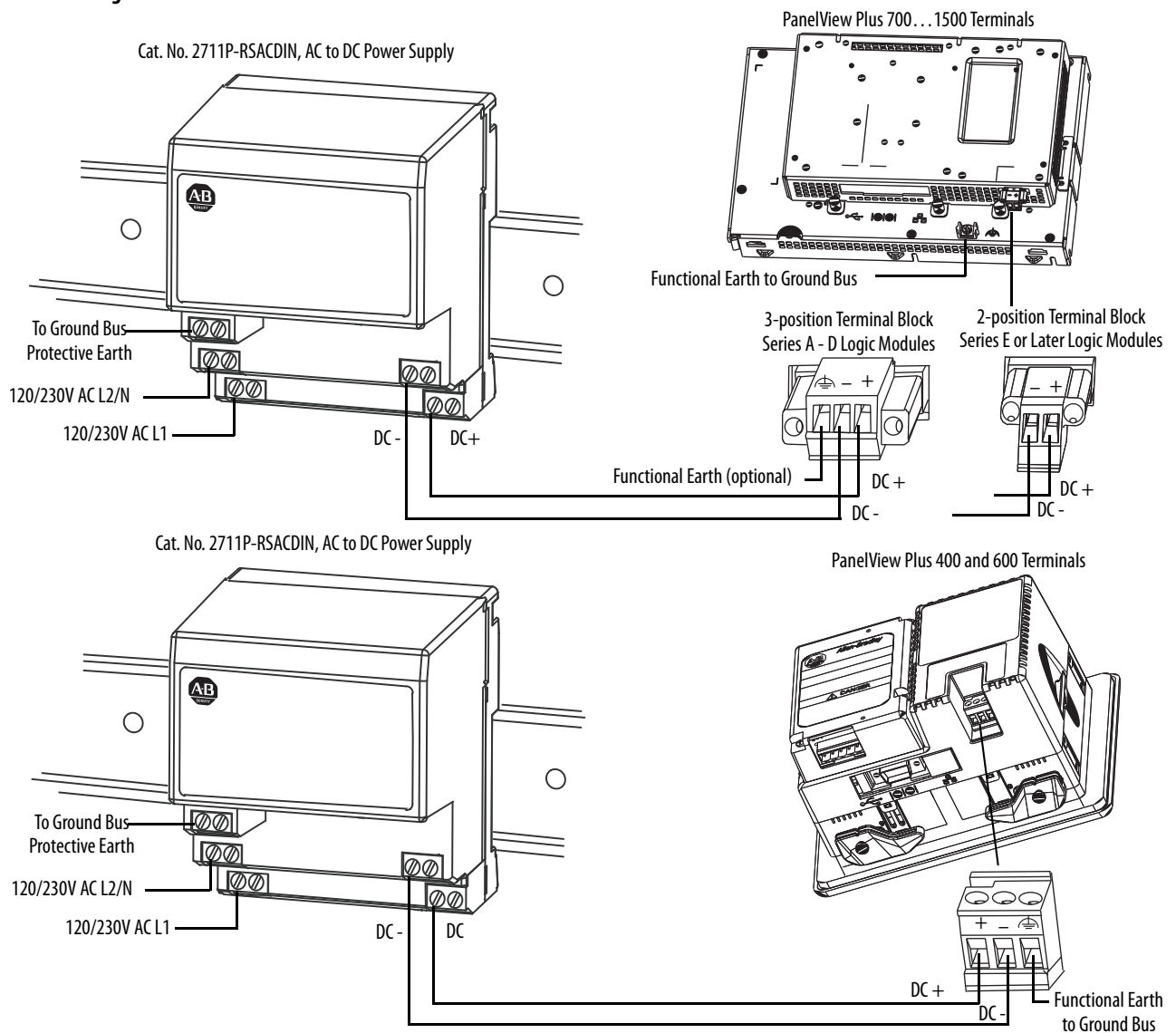

PanelView Plus Isolated DC Terminals

The 700...1500 terminals with an isolated DC power input use the following:

- Isolated DC logic module
- Earth/ground connection

Terminals with an isolated DC logic module do not require a separate power supply to power multiple devices.

Isolated DC Logic Modules

All PanelView Plus 6 terminals (700...1500 models) that operate on DC power use an isolated DC logic module. Some PanelView Plus 700...1500 terminals running FactoryTalk View ME software, version 5.1 or earlier, support logic modules with an isolated DC power input.

Table 5 - Isolated DC Logic Modules

Cat. No.	Logic Modules with Isolated DC Power Input
PanelView Plus 6 Terminals (700...1500)	
2711P-RP8D	Logic module with 512 MB nonvolatile memory and RAM
2711P-RP8DK	Conformal-coated logic module with 512 MB nonvolatile memory and RAM
2711P-RP9D	Logic module with 512 MB nonvolatile memory and RAM
2711P-RP9DK	Conformal-coated logic module with 512 MB nonvolatile memory and RAM
PanelView Plus 700...1500 Terminals ⁽¹⁾	
2711P-RP1D	Marine-certified logic module with 64 MB nonvolatile memory and RAM
2711P-RP2D	Marine-certified logic module with 128 MB nonvolatile memory and RAM
2711P-RP6D	Marine-certified, CE logic module with 128 MB nonvolatile memory and RAM
2711P-RP2DK	Conformal-coated logic module with 128 MB nonvolatile memory and RAM
2711P-RP6DK	CE conformal-coated logic module with 128 MB nonvolatile memory and RAM
2711P-RP3D	Marine-certified logic module with 256 MB nonvolatile memory and RAM
2711P-RP7D	Marine-certified CE logic module with 256 MB nonvolatile memory and RAM

(1) These logic modules support FactoryTalk View ME software, version 5.1 or earlier.

IMPORTANT Refer to [Communication Port Isolation on page 20](#) for information on communication port isolation.

External Power Supply for Isolated DC Terminals

Use a SELV or PELV, 24V DC power supply, such as catalog number 2711P-RSACDIN, to power a PanelView Plus 700...1500 terminal with an isolated DC logic module.

The isolated DC terminals may be powered by the same power source as other equipment, a DC power bus.



ATTENTION: Use a SELV or PELV supply as required by local wiring codes for your installation. The SELV and PELV power sources provide protection so that under normal and single fault conditions, the voltage between conductors and earth/ground does not exceed a safe value.

Earth/Ground Connection for Isolated DC Terminals

PanelView Plus 700...1500 terminals with an isolated DC power supply have an earth/ground terminal that you must connect to a low-impedance earth/ground.

IMPORTANT The earth/ground connection to ground is mandatory. This connection is required for noise immunity, reliability, and Electromagnetic Compliance (EMC) with the European Union (EU) EMC Directive for CE-mark conformance and for safety by Underwriters Laboratory (UL).

The earth/ground connection is on the rear of the display module. The earth/ground terminal wiring requires a minimum wire gauge.

Table 6 - Earth/Ground Wiring for Isolated DC Terminals

PE Symbol	Wire Type		Wire Gauge	Terminal Screw Torque
 GND	Cu 90 °C (194 °F)	Copper (stranded or solid)	2.1...5.3 mm ² (14...10 AWG)	1.13...1.36 N·m (10...12 lb·in)



ATTENTION: Damage or malfunction can occur when a voltage potential exists between two separate ground points. Make sure the PanelView Plus terminal does not serve as a conductive path between two ground points at different potentials.

The earth/ground terminal is typically connected to a system grounding bus. If the grounding bus has tapped holes, the conductor from the functional earth terminal must have a ground lug on the ground bus end. A bolt should pass through a star washer, then through the ground conductor lug, then into the ground bus.

Use the shortest, practical wire length to connect the earth/ground to a low-impedance earth/ground. The ground wire must be either green or green with a yellow stripe. Refer to local wiring codes and regulations for grounding requirements.

Figure 5 - Earth/Ground Connection for 700...1500 Isolated DC Terminals

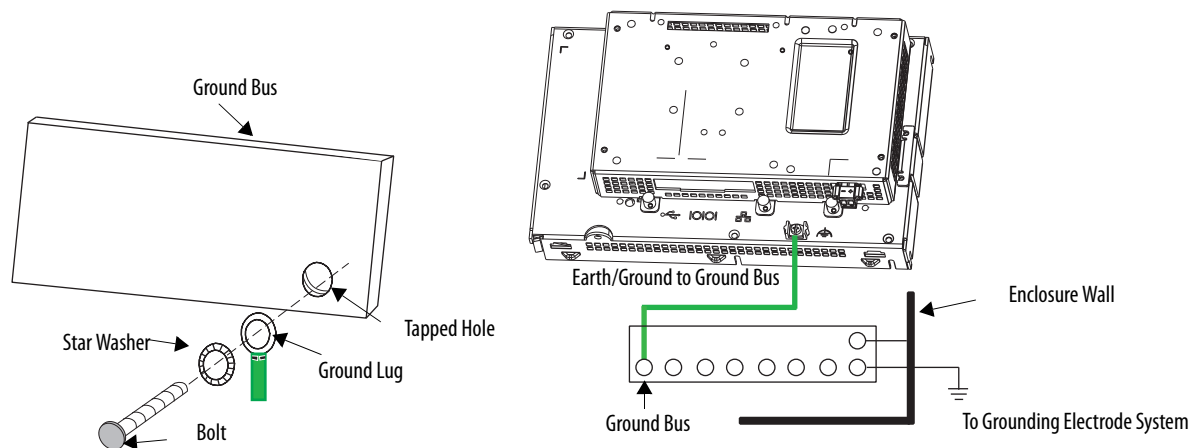

AC-to-DC Power Supply to Power Isolated DC Terminals

Powering a PanelView Plus terminal with an isolated DC logic module from an AC power source requires an AC-to-DC power supply with a SELV output, or the 2711P-RSACDIN power supply.

Catalog number 2711P-RSACDIN is a UL accepted power supply for the PanelView Plus terminals. The power supply converts AC power to DC power, provides a SELV output, and has electrical input rating of 100...240V AC (50...60 Hz).

These are the electrical output ratings of the power supply:

- 24V DC nominal
- 3 A maximum

For more information on this power supply, refer to the AC Power Supply Installation Instructions, publication [2711P-IN005](#).

Figure 6 - Power Supply for Isolated DC Terminals

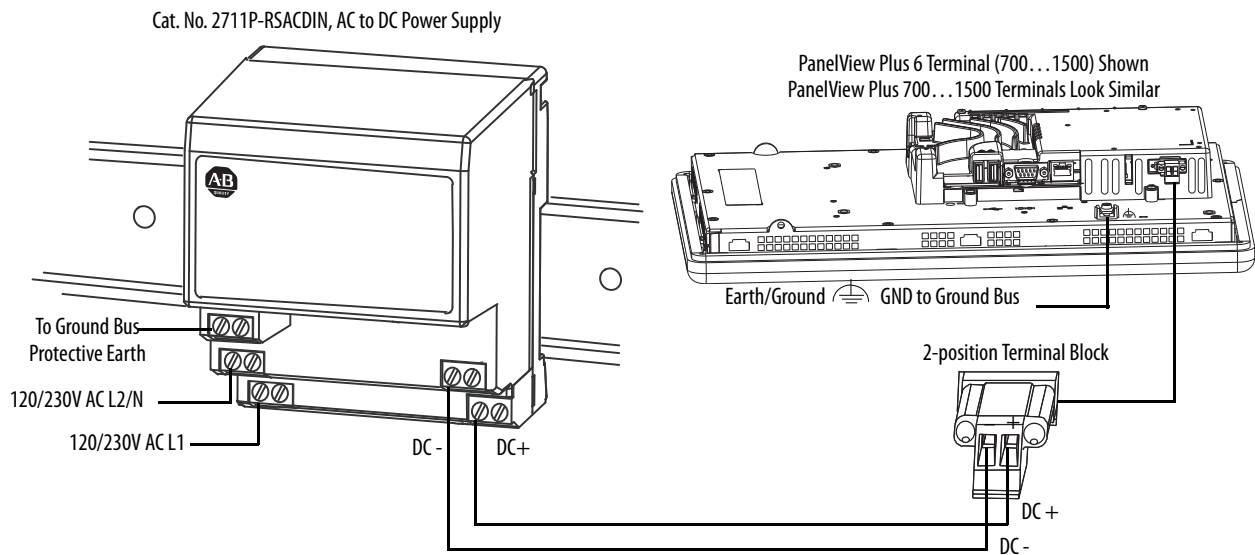

Connect PanelView Plus DC Terminals to DC Power

PanelView Plus terminals with a 24V DC power input have these power ratings.

Table 7 - DC Power Ratings

Terminal	Input Range
PanelView Plus 400 and 600 PanelView Plus Compact 400 and 600	24V DC nom (18...30V DC) 25 W max (1.0 A at 24V DC)
PanelView Plus 6 (700...1500) PanelView Plus 700...1500 PanelView Plus Compact 1000	24V DC nom (18...32V DC) 70 W max (2.9 A at 24V DC)

The power supply is internally protected against reverse polarity of the DC+ and DC- connections. Connecting DC+ or DC- to the earth terminal may damage the device.

Table 8 - Wire Specifications for DC Power Terminal Block

Terminal	Wire Type		Dual-wire Gauge ⁽²⁾	Single-wire Gauge	Terminal Screw Torque
PanelView Plus 400 and 600 PanelView Plus Compact 400 and 600	Copper (stranded or solid)	Cu 90 °C (194 °F)	0.3...1.3 mm ² 22...16 AWG	0.3...2.1 mm ² 22...14 AWG	0.45...0.56 N·m (4...5 lb·in)
700...1500 logic module series A...D ⁽¹⁾					0.23...0.34 N·m (2...3 lb·in)
700...1500 logic module series E and later ⁽¹⁾	Copper (stranded or solid)	Cu 90 °C (194 °F)	0.3...1.3 mm ² 22...16 AWG	0.3...2.1 mm ² 22...14 AWG	0.56 N·m (5 lb·in)
PanelView Plus Compact 1000					
PanelView Plus 6 terminals series A or later					

(1) Terminals with these logic modules support FactoryTalk View ME software, version 5.1 or earlier.

(2) Two-wire maximum per terminal.

Follow these steps to connect a PanelView Plus device to a DC power source.



WARNING: Explosion Hazard

Do not disconnect equipment unless power has been switched off and the area is known to be nonhazardous.

Disconnect all power before installing or replacing components. Failure to disconnect power may result in electrical shock or damage to the device.

1. Verify that the device is not connected to a power source.
2. Secure the DC power wires to the terminal block.

Make sure you connect the DC+ and DC- wires to the correct positions on the power terminal block.

3. Secure the earth/ground wire.
 - On the 400 and 600 terminals, secure the earth/ground wire to the functional earth/ground terminal on the input power terminal block.
 - On the 700...1500 terminals, secure the earth/ground wire to the earth/ground terminal screw at the bottom of the display.

4. Apply 24V DC power to the terminal.

Figure 7 - DC Power Connections

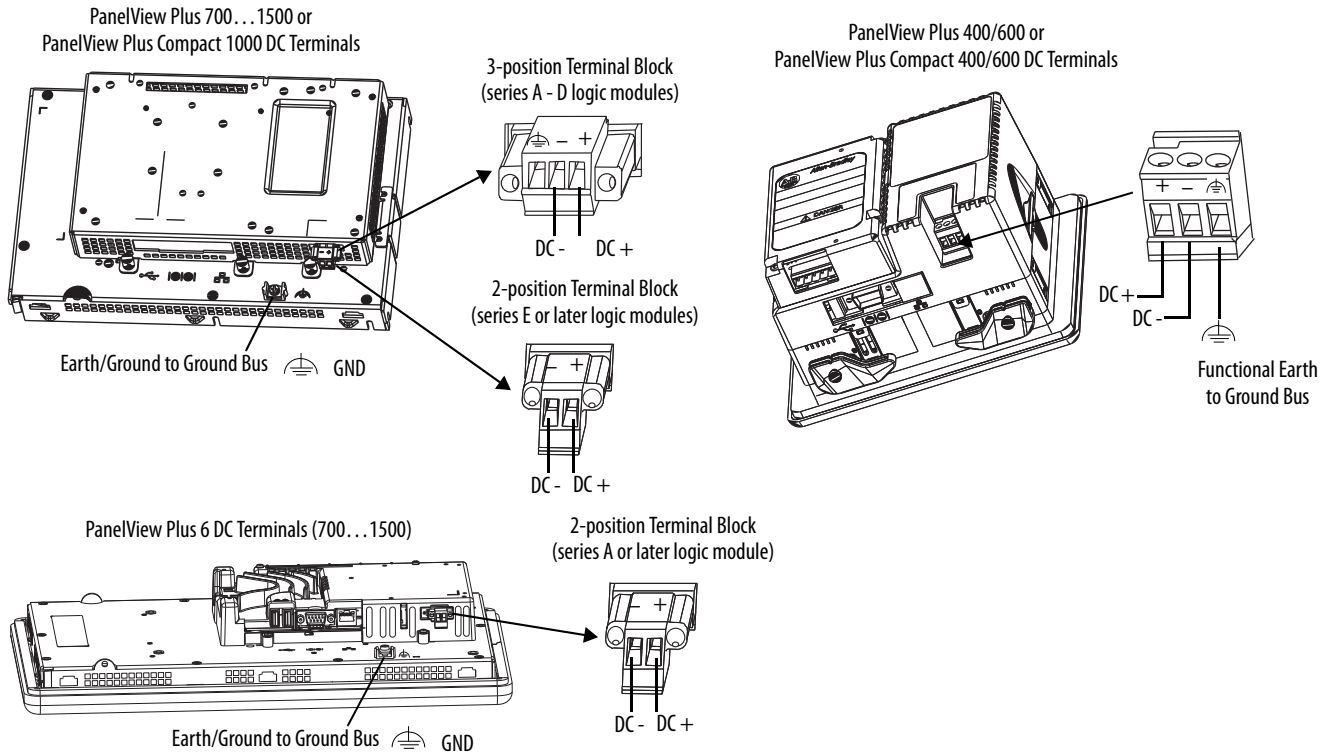

Using Isolated DC Logic Modules in Marine Applications

Isolated DC logic modules that are marine-certified require a line filter for use in marine applications. Use Corcom 6VW1 or equivalent filter type.

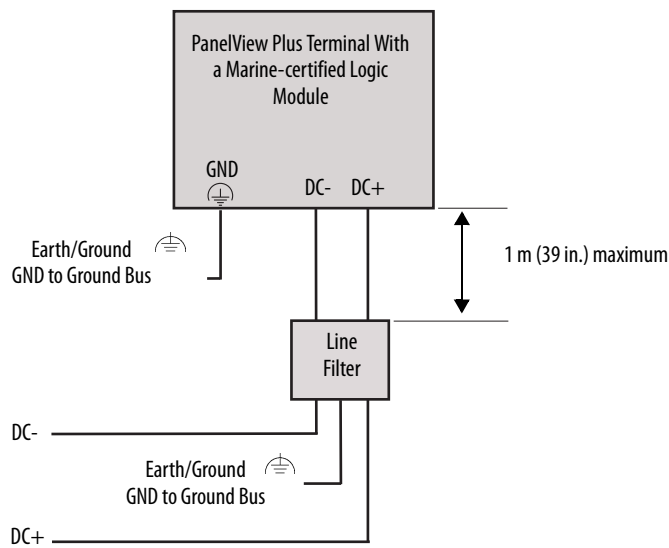

PanelView Plus AC Terminals

PanelView Plus terminals that operate on AC power require the following:

- Protective earth/ground connection on the 400 and 600 terminals
- Protective earth/ground and a functional earth/ground connection on the 700...1500 terminals

PanelView Plus 400 and 600 AC Terminals

All PanelView Plus 400 and 600 terminals operate on AC power.

Table 9 - PanelView Plus Terminals with AC Power Supplies

Cat. No.	Terminal Type
<ul style="list-style-type: none"> • 2711P-K4M5A, 2711P-K4M20A • 2711P-K4C5A, 2711P-B4C5A • 2711P-K4C20A, 2711P-B4C20A 	PanelView Plus 400
<ul style="list-style-type: none"> • 2711P-K6M5A, 2711P-T6M5A, 2711P-B6M5A • 2711P-K6M20A, 2711P-B6M20A • 2711P-K6C5A, 2711P-T6C5A, 2711P-B6C5A • 2711P-K6C20A, 2711P-T6C20A, 2711P-B6C20A 	PanelView Plus 600

PanelView Plus 700...1500 AC Logic Modules

All PanelView Plus 6 and PanelView Plus 700...1500 terminals that operate on AC power use an AC logic module.

Table 10 - AC Logic Modules

Cat. No.	Logic Modules with AC Power Input
PanelView Plus 6 (700...1500) Terminals	
2711P-RP8A	Logic module with 512 MB nonvolatile memory and RAM
2711P-RP9A	Logic module with 512 MB nonvolatile memory and RAM
PanelView Plus 700...1500 Terminals ⁽¹⁾	
2711P-RPA	Logic module without nonvolatile memory and RAM
2711P-RP1A	Marine-certified logic module with 64 MB nonvolatile memory and RAM
2711P-RP2A	Marine-certified logic module with 128 MB nonvolatile memory and RAM
2711P-RP6A	Marine-certified CE Logic module with 128 MB nonvolatile memory and RAM
2711P-RP3A	Marine-certified logic module with 256 MB nonvolatile memory and RAM
2711P-RP7A	Marine-certified CE logic module with 256 MB nonvolatile memory and RAM

(1) These logic modules support FactoryTalk View ME software, version 5.1 or earlier.

Protective Earth Connection for AC Terminals

PanelView Plus terminals with an AC power input have a protective earth/ground terminal that you must connect to a low-impedance earth/ground.

IMPORTANT The protective earth connection is required for both electrical safety and Electromagnetic Compliance (EMC) with the European Union (EU) EMC Directive for CE-mark conformance.

The protective earth/ground connection is on the power input terminal block. The protective earth terminal requires a minimum wire gauge.

Table 11 - Protective Earth Wiring on AC Terminals

Terminal	PE Symbol	Wire Type		Wire Gauge	Terminal Screw Torque
400 and 600		Copper (stranded or solid)	Cu 90 °C (194 °F)	2.1...3.3 mm ²	0.45...0.56 N·m (4...5 lb·in)
700...1500 ⁽¹⁾				14...12 AWG	
				2.1...3.3 mm ²	0.56 N·m (5 lb·in)
				14...12 AWG	

(1) Includes PanelView Plus 6 terminals and PanelView Plus terminals supporting FactoryTalk View ME software, version 5.1 or earlier.

The protective earth/ground terminal is typically connected to a system grounding bus. If the grounding bus has tapped holes, the conductor from the functional earth terminal must have a ground lug on the ground bus end. A bolt should pass through a star washer, then through the ground conductor lug, then into the ground bus.

Use the shortest, practical wire length to connect the protective earth/ground to a low-impedance earth/ground. The ground wire must be either green or green with a yellow stripe.

Refer to local wiring codes and regulations for grounding requirements.

Figure 8 - Protective Earth Connection for 400 and 600 AC Terminals

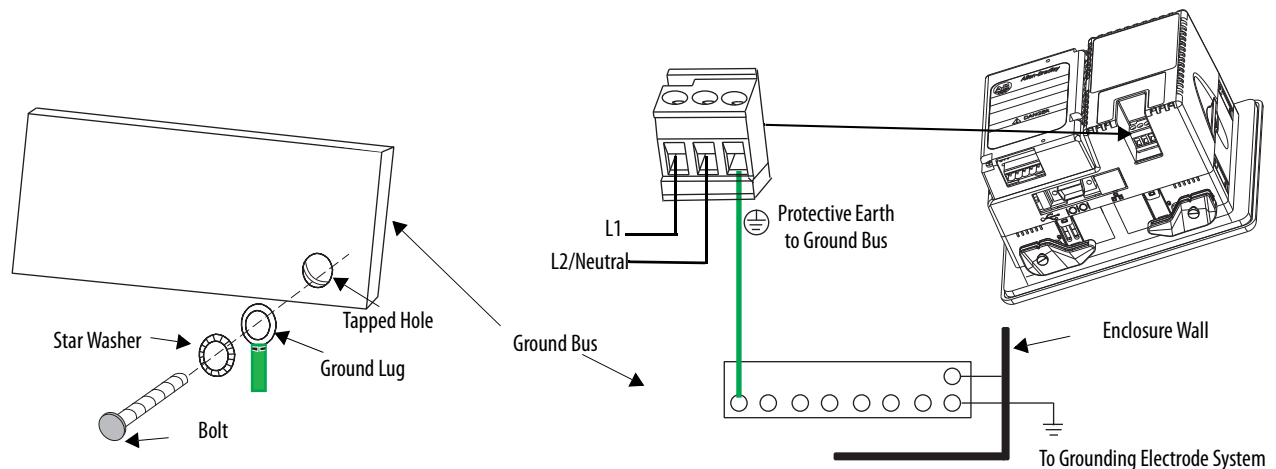

Functional Earth Connection for 700...1500 AC Terminals

PanelView Plus 700...1500 terminals with an AC power input have these features:

- Protective earth terminal on the power terminal block
- Functional earth/ground connection on the back of the display

IMPORTANT On PanelView Plus 700...1500 AC terminals, you must connect both protective earth and functional earth to ground.



ATTENTION: The functional earth and protective earth connections to ground are mandatory. The functional earth/ground connection is required for Electromagnetic Compliance (EMC) with the European Union (EU) EMC Directive for CE-mark conformance. The protective earth/ground connection is required for safety and regulatory compliance.

Figure 9 - Protective Earth and Functional Earth Connection for 700...1500 AC Terminals

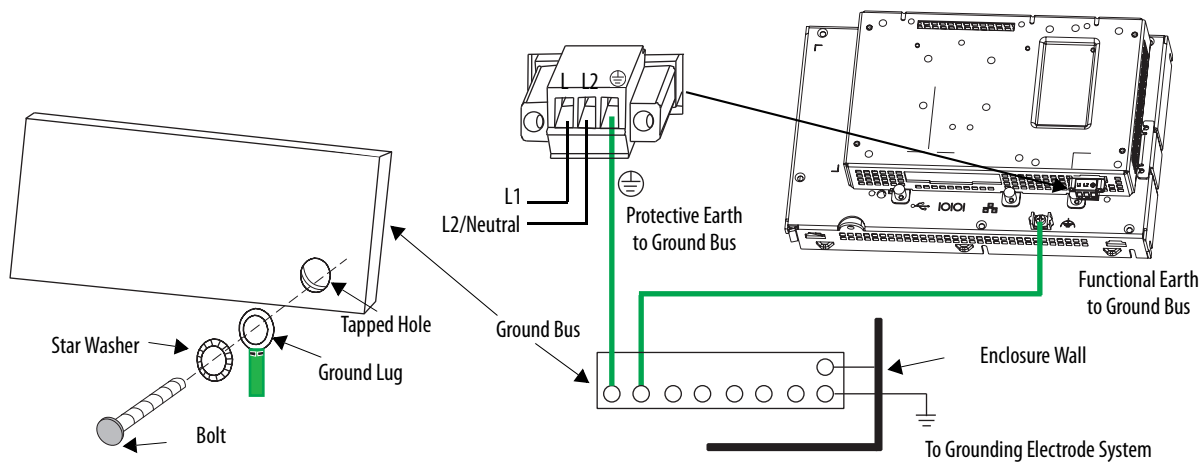

Connect to AC Power

PanelView Plus terminals with an AC power input have these power ratings.

Table 12 - AC Power Ratings

Terminal	Voltage Range	Frequency	VA
400 and 600	100...240V AC	50...60 Hz	60VA max
700...1500 ⁽¹⁾	100...240V AC	50...60 Hz	160VA max

(1) Includes PanelView Plus 6 terminals and PanelView Plus terminals supporting FactoryTalk View ME software, version 5.1 or earlier.

The input power terminal block supports these wire sizes.

Table 13 - Wire Specifications for AC Power Terminal Block

Terminal	Wire Type	Dual-Wire Gauge ⁽²⁾	Single-Wire Gauge	Terminal Screw Torque
400 and 600	Copper (stranded or solid)	Cu 90 °C (194 °F)	0.3...2.1 mm ² 22...14 AWG	0.45...0.56 N·m (4...5 lb·in)
700...1500 ⁽¹⁾			0.3...1.3 mm ² 22...16 AWG	0.56 N·m (5 lb·in)

(1) Includes PanelView Plus 6 terminals and PanelView Plus terminals supporting FactoryTalk View ME software, version 5.1 or earlier.

(2) Two-wire maximum per terminal.

Follow these steps to connect the terminal to AC power.

1. Verify that the terminal is not connected to a power source.
2. Secure the AC power wires to the terminal block.
Follow the markings on the terminal block and terminal for proper connections.
3. Secure the protective earth/ground wire to the marked position on the power input terminal block.
4. On 700...500 devices, also secure the functional earth/ground wire to the functional earth terminal screw on the back of the display to ground bus.

Figure 10 - AC Power Connections

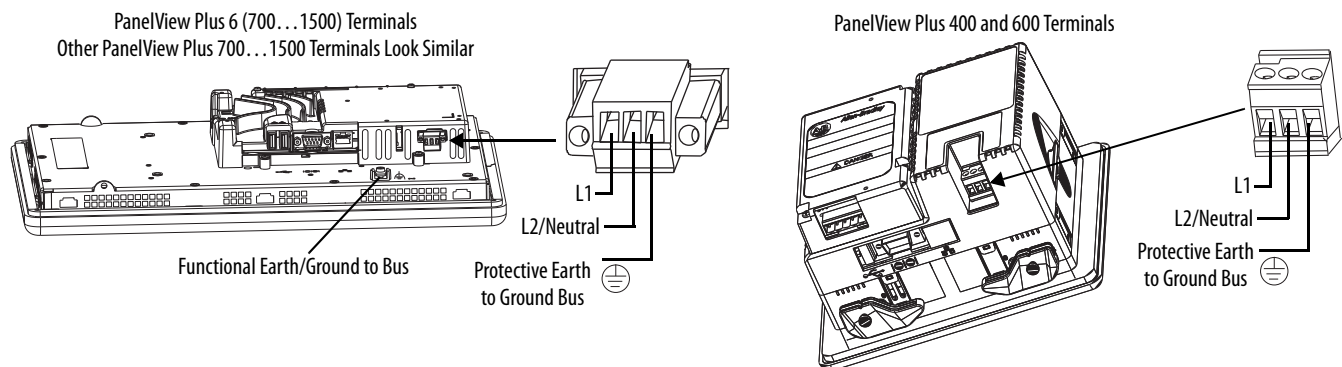

Communication Port Isolation

PanelView Plus terminals contain integral and modular (externally attached) communication ports. Some of these ports contain electrical isolation depending on the catalog number of the terminal or communication module.

Table 14 - Integral Communication Port Isolation

Communication Port	400 and 600 Terminals	700...1500 Terminals ⁽¹⁾
RS-232	Nonisolated	Isolated
USB	Nonisolated	Nonisolated
Ethernet	Isolated	Isolated

(1) Includes PanelView Plus 6 terminals and PanelView Plus terminals supporting FactoryTalk View ME software, version 5.1 or earlier.

Table 15 - 400 and 600 Modular Communication Port Isolation

Communication Port	Module	Isolation
RS-232	2711P-RN22C	Isolated
DH-485	2711P-RN3	Nonisolated
DH+™	2711P-RN8	Isolated
Remote I/O	2711P-RN1	Isolated
DeviceNet	2711P-RN10C	Isolated
ControlNet	2711P-RN15C	Isolated ⁽¹⁾

(1) NAP port is nonisolated.

Table 16 - 700...1500 Modular Communication Port Isolation

Communication Port	Module	Isolation
DH-485	2711P-RN6, 2711P-RN6K	Isolated
DH+	2711P-RN6, 2711P-RN6K	Isolated
Remote I/O ⁽¹⁾	2711P-RN6	Isolated
DeviceNet ⁽¹⁾	2711P-RN10H	Isolated
ControlNet	2711P-RN15S, 2711P-RN15SK	Isolated

(1) Remote I/O and DeviceNet networks are supported but no longer available for order.

Ethernet Cable

To comply with European Union 89/336/EEC EMC Directive and Marine emission limits, use these Ethernet components with the PanelView Plus 700...1500 terminals:

- Belden 7921A shielded Ethernet Cat 5E cable according to TIA 568-B.1
- RJ45 connector according to IEC 60603-7

The recommended RJ45 connector is available from Sentinel Connector Systems, Inc. as part number 106S08080058C34.

The maximum cable length between the Ethernet port and a 10/100 Base-T port on the Ethernet hub (without repeaters or fiber) is 100 m (328 ft).



WARNING: Explosion Hazard

Do not connect or disconnect any communication cable with power applied to this device or any device on the network. An electrical arc could cause an explosion in hazardous location installations. Be sure that power is removed or the area is nonhazardous before proceeding.

Guidelines for Powering Nonisolated DC PanelView Plus Terminals

To apply 24V DC power to a nonisolated PanelView Plus terminal, you must follow specific guidelines in addition to regulatory requirements:

- Use the appropriate power supply.
- Use multiple power supplies for a system with multiple PanelView Plus terminals.
- Use a single point ground.
- Wire the terminal block correctly.
- Apply the correct input voltage to the PanelView Plus terminal.



ATTENTION: Disconnect all power before installing or replacing components. Failure to disconnect power may result in electrical shock or damage to the device.

Use the Appropriate Power Supply

Each nonisolated PanelView Plus terminal in a system must be powered by its own power supply with the correct electrical ratings. Use a UL Class 2 or an IEC SELV power source to meet regulatory, electrical shock, and fire prevention requirements.

The PanelView Plus 700...1500 terminals with an isolated DC logic module do not require the use of a UL Class 2 power source for UL installations.

The supply you choose depends on the regulatory agency that is applicable to the installation. The 2711P-RSACDIN power supply is approved for use with PanelView Plus terminals in most installations.

[Refer to Connect PanelView Plus DC Terminals to DC Power on page 14](#) for an explanation of the power source requirements.

Power the Nonisolated DC PanelView Plus Terminals

For systems with nonisolated DC PanelView Plus terminals, you must use a separate converter or power supply to power each terminal.

To power multiple PanelView Plus DC terminals from one DC power supply, use an isolated DC-to-DC converter with each terminal. The current from each converter returns to the converter through the DC- wiring. This prevents DC-current from returning to the PanelView Plus terminal through earth/ground and damaging the terminal.

Figure 11 - Isolated DC-to-DC Converters to Power Multiple DC Terminals

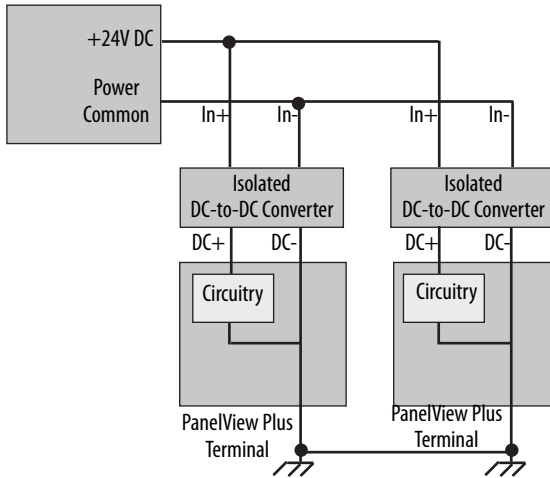

If a system contains multiple PanelView Plus DC terminals, use a separate AC-to-DC power supply with each device. The current from each supply returns to the power supply via the DC- wiring.

Figure 12 - Separate AC Power Supplies to Power Multiple DC Terminals

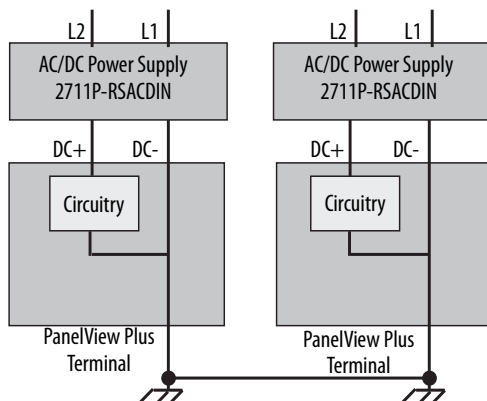

Use a Single Point Ground

Verify that the circuit powering the PanelView Plus terminal has only one point where DC- is connected to earth/ground. This connection is usually internal to the PanelView Plus terminal.

A circuit with DC- connected to earth/ground at more than one point has portions of its DC- wiring electrically paralleled by an earth/ground path. Current intended to return to the power source in the DC- wiring can return to the power source through the parallel, earth/ground path.

IMPORTANT For regulatory and reliability reasons, current must return to its power source through the DC- wiring, not through earth/ground.

Most PanelView Plus terminals have DC- connected to earth/ground internally in the product. Circuits powering these terminals must not have another DC- point connected to earth/ground. Otherwise, the DC- current will flow through the earth/ground wiring and earth/ground structure. Current flowing through earth/ground can damage the terminal.

IMPORTANT No other location powered by the same power source can have DC- connected to earth/ground because the PanelView Plus terminal has the internal ground connection.

Connect the Power Wires Correctly



ATTENTION: Do not perform a dielectric strength test on the nonisolated DC powered terminals. High voltage will damage the product.

Make sure you connect the DC+ and DC- wires to the correct positions on the power terminal block. The product is protected against the reversal of the DC+ and DC- connections. However, some miswiring combinations of the power terminals and earth/ground or the communication wiring can damage the PanelView Plus terminal or connected equipment.

Apply Correct Input Voltage



ATTENTION: Apply the correct voltage type to the DC power terminal block.
Do not connect an AC power source to the DC power terminal block. This will damage the PanelView Plus terminal.

Guidelines for Powering the Isolated DC PanelView Plus Terminals

To apply 24V DC power to the isolated PanelView Plus terminal, you must follow specific guidelines in addition to regulatory requirements:

- A separate power supply is not required to power the isolated DC PanelView Plus terminals.
- Wire the terminal block correctly.
- Apply the correct input voltage to the PanelView Plus terminal.



ATTENTION: Disconnect all power before installing or replacing components. Failure to disconnect power may result in electrical shock or damage to the device.

Power the Isolated DC PanelView Plus Terminals

The PanelView Plus 700...1500 isolated DC terminals support a power source with its output common connected to earth/ground, such as a PELV power supply. The DC- input to the isolated PanelView Plus terminal is not connected to earth/ground internally within the product.

The PanelView Plus 700...1500 isolated DC terminals do not require a separate power source for each terminal.

Connect the Power Wires Correctly

Make sure you connect the DC+ and DC- wires to the correct positions on the power terminal block. The product is protected against the reversal of the DC+ and DC- connections. However, some miswiring combinations of the power terminals and earth/ground or the communication wiring can damage the PanelView Plus terminal or connected equipment.

Apply Correct Input Voltage

Apply the correct voltage type to the DC power terminal block.



ATTENTION: Do not connect an AC power source to the DC power terminal block. This will damage the PanelView Plus terminal.

How to Avoid Grounding Problems

This section provides details on how to avoid grounding problems:

- [Multiple Ground Connections](#)
- [High Current from Multiple Ground Connections](#)
- [Ground Shift Problem](#)
- [Ground Reference Problem](#)

Multiple Ground Connections

It is important to avoid multiple ground connections with nonisolated and isolated PanelView Plus terminals.

Nonisolated DC PanelView Plus Terminals

The internal DC power supply of the nonisolated PanelView Plus terminals does not isolate the output voltages from the input voltages. On some PanelView Plus terminals, DC- is internally connected to functional earth/ground (and chassis). If another device by using the same power source has a DC- common to the earth/ground connection, then two parallel-current paths exist:

- One path leads from the DC- of the PanelView Plus terminal to the DC- common of the other grounded device.
- One path leads from the earth/ground terminal of the PanelView Plus terminal to the earth/ground connection of the other grounded device.

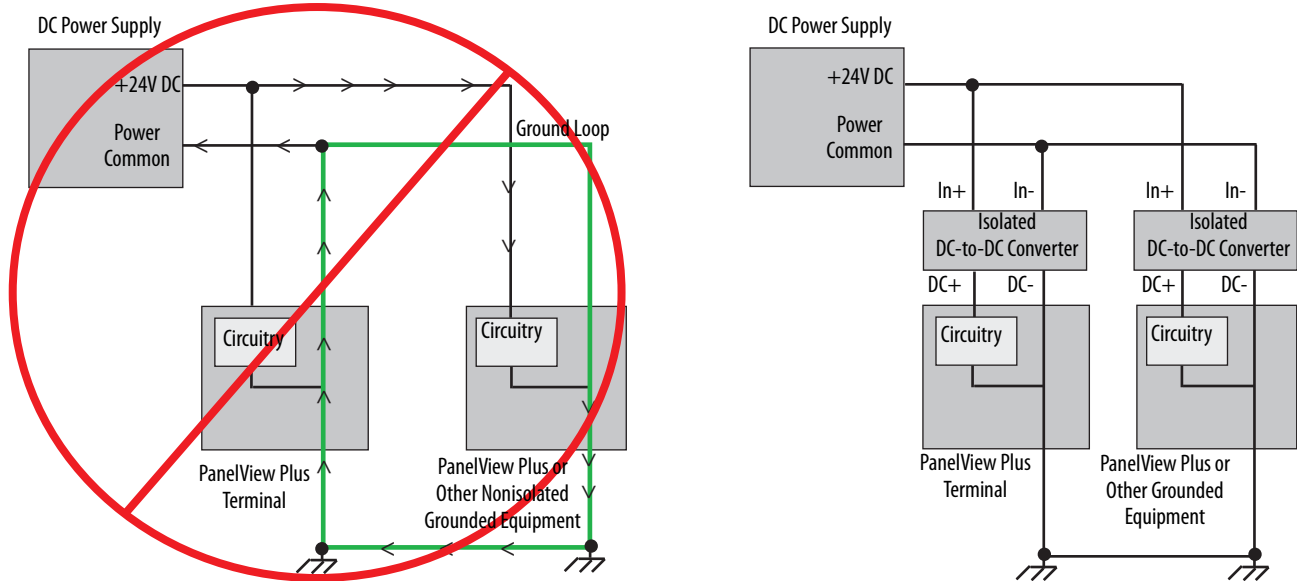

A ground loop occurs in a system with parallel ground paths. A ground loop can cause excessive current to flow in the PanelView Plus terminal. Excessive current flow can damage the PanelView Plus terminal.

Isolated DC PanelView Plus Terminals

The power supply of the isolated DC PanelView Plus 700...1500 terminals lets you power multiple terminals from one DC power source without creating a ground loop.

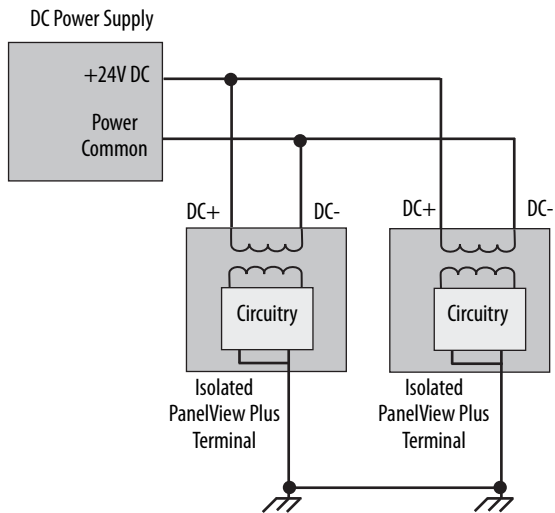

High Current from Multiple Ground Connections

The illustration below shows one 24V DC power supply providing power to a DC motor and a nonisolated PanelView Plus terminal. Because DC- is connected to earth/ground in the motor and the PanelView Plus terminal, two paths exist for the current to return to the power supply. The motor current can flow through the system's earth/ground structure into the PanelView Plus terminal, and back to the power supply.

Because the system's earth/ground structure has a lower impedance than the common wiring, the motor current will flow through earth/ground and the PanelView Plus terminal. The motor current could damage the terminal.

Nonisolated DC PanelView Plus Terminals

Use a separate power supply for each device; one to power the nonisolated PanelView Plus terminal and one to power the motor. The current will return to each power supply through the DC- wiring instead of the earth/ground structure.

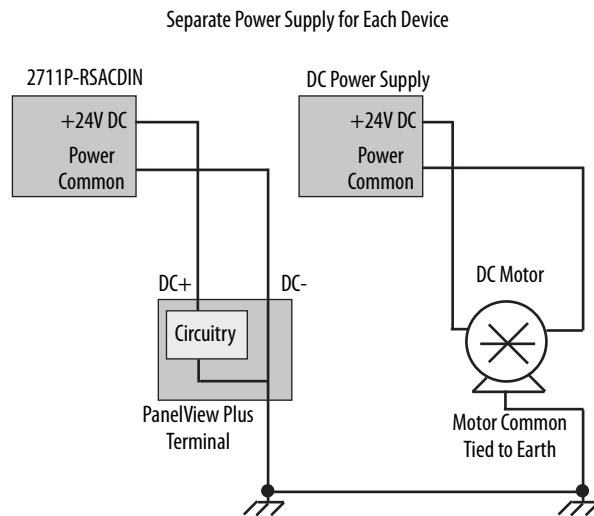
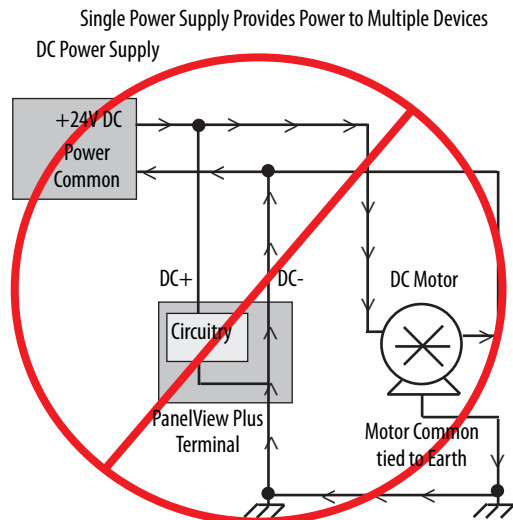

Isolated DC PanelView Plus Terminals

The isolated DC PanelView Plus terminals can be used in a system with other DC equipment, powered by a single DC power source.

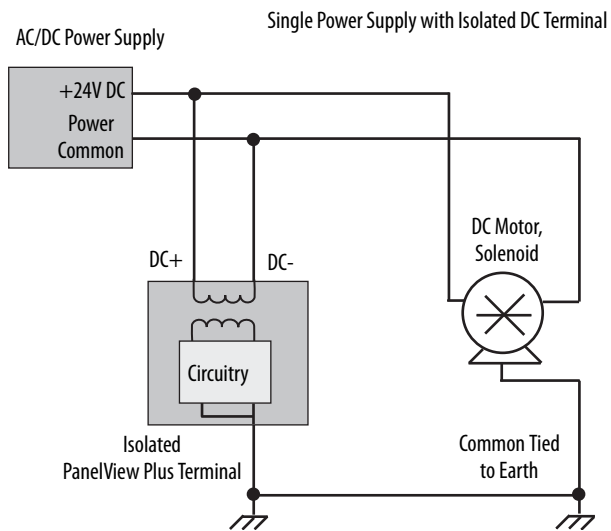

Ground Shift Problem

On most PanelView Plus DC terminals, DC- is internally connected to functional earth/ground. Some PanelView Plus communication options do not isolate the communication common from the DC- terminal. In the nonisolated communication options, current can flow from the communication common through the PanelView Plus device and out the DC- or functional earth terminal.

Refer to [Communication Port Isolation on page 20](#) for a list of isolated and nonisolated communication ports on PanelView Plus terminals.

If the device connected to the communication port is referenced to the same ground potential as the PanelView Plus power supply, this configuration is not a problem. However, remote communication devices can be referenced away from the terminal's earth ground.

If the communication device is remote from the PanelView Plus terminal and has nonisolated ports, both devices are referenced as close as their earth/grounds are referenced. Events such as lightning, ESD, or motor drive noise may cause the PanelView Plus terminal or the communication device to be referenced away from the earth/ground potential. This causes high current to flow from the terminal's earth/ground to its common, through the communication wiring, and out the communication device's earth ground.

High or sustained current can damage the PanelView Plus terminal. Use isolated communication for remote or noisy locations.

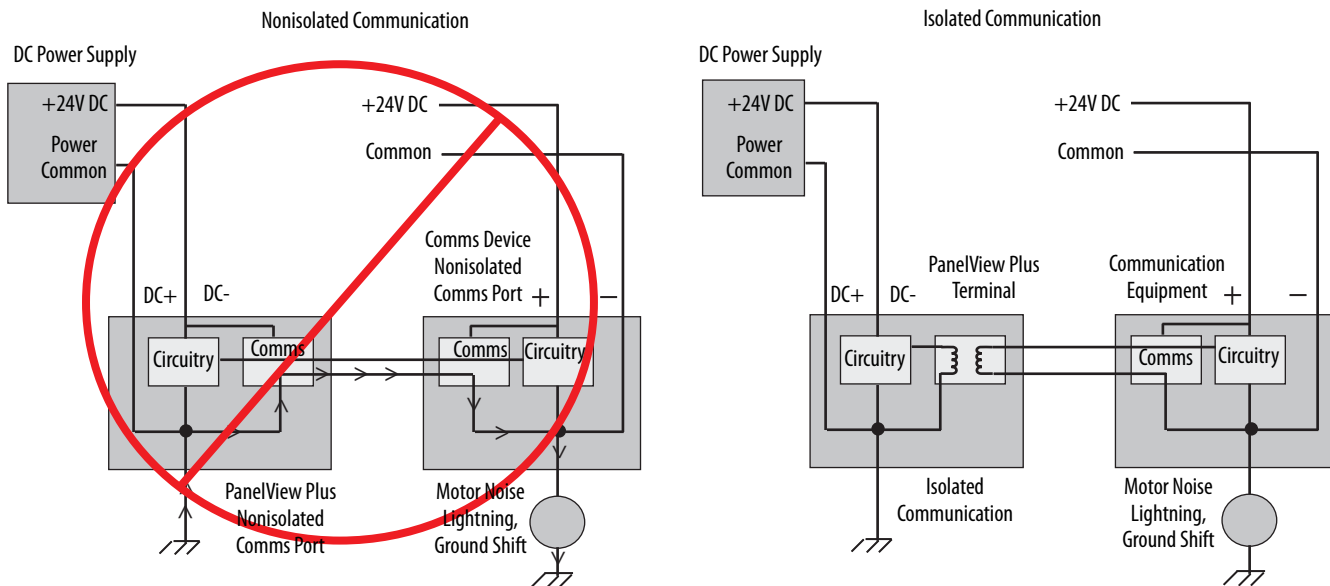

Ground Reference Problem

A ground reference problem can occur if the equipment communicating with the PanelView Plus terminal, using nonisolated communication lines on both ends, is referenced away from earth ground by its power supply. Some systems have voltages other than +24V, such as -24V DC. The communication equipment might use these connections:

- +24V DC input is connected to the power supply common.
- Common is connected to the -24V DC power supply.

These connections provide +24V DC across the communication equipment power supply and do not present a problem with the communication equipment alone. However, when the communication equipment is connected to the PanelView Plus terminal, the -24V DC power supply is shorted to the device's DC- and earth ground. High or sustained current in the PanelView Plus terminal can damage the device. Use communication lines that are isolated on at least one end.

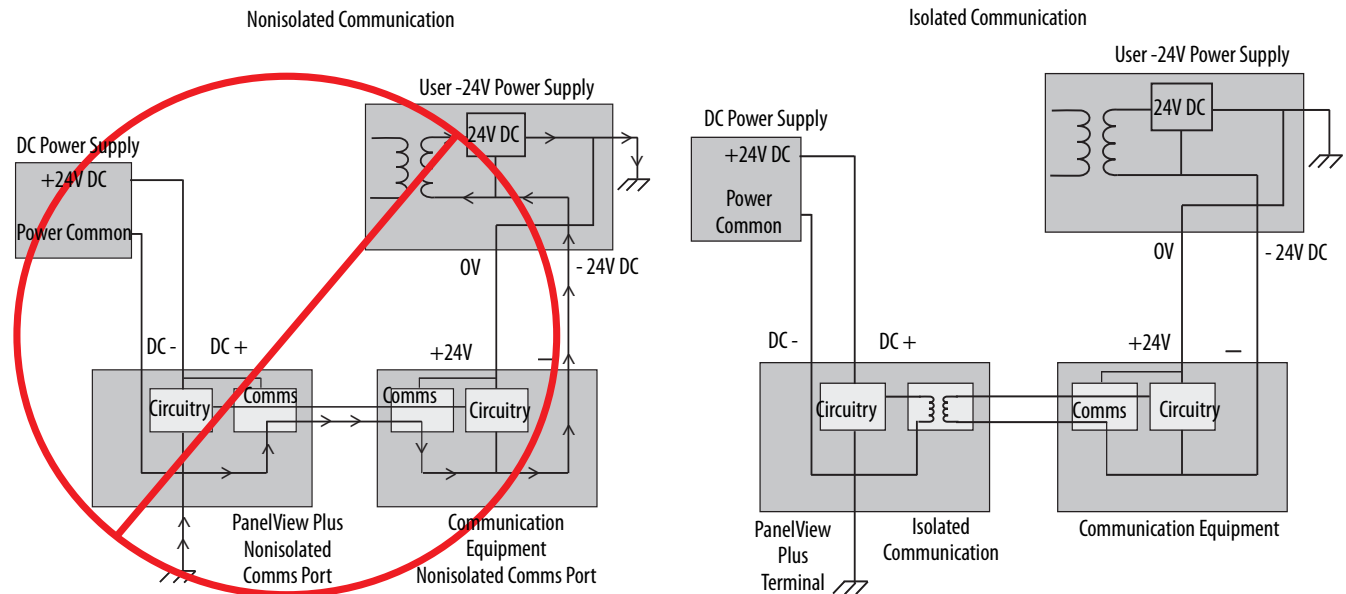

Additional Resources

These documents contain additional information concerning related products from Rockwell Automation.

Resource	Description
PanelView Plus 6 Terminals User Manual, publication 2711P-UM006	Provides an overview of PanelView Plus 6 terminals and gives information on how to install, operate, configure, and troubleshoot these devices.
PanelView Plus Terminals User Manual, publication 2711P-UM001	Provides an overview of the PanelView Plus and PanelView Plus CE terminals and gives information on how to install, operate, configure, and troubleshoot these devices. These terminals support FactoryTalk View ME software, version 5.1 or earlier.
PanelView Plus Compact Terminals User Manual, publication 2711PC-UM001	Provides an overview of PanelView Plus Compact terminals and gives information on how to install, operate, configure, and troubleshoot these devices.
AC Power Supply Installation Instructions, publication 2711P-IN005	Provides an overview of the AC power supply and provides procedures on how to install and wire the power supply to the PanelView Plus terminals.
Industrial Automation Wiring and Grounding Guidelines, publication 1770-4.1	Provides general guidelines for installing a Rockwell Automation industrial system.
Product Certifications website, http://www.ab.com	Provides declarations of conformity, certificates, and other certification details.

You can view or download publications at <http://www.rockwellautomation.com/literature/>. To order paper copies of technical documentation, contact your local Allen-Bradley distributor or Rockwell Automation sales representative.

Important User Information

Read this document and the documents listed in the additional resources section about installation, configuration, and operation of this equipment before you install, configure, operate, or maintain this product. Users are required to familiarize themselves with installation and wiring instructions in addition to requirements of all applicable codes, laws, and standards.

Activities including installation, adjustments, putting into service, use, assembly, disassembly, and maintenance are required to be carried out by suitably trained personnel in accordance with applicable code of practice.

If this equipment is used in a manner not specified by the manufacturer, the protection provided by the equipment may be impaired.

In no event will Rockwell Automation, Inc. be responsible or liable for indirect or consequential damages resulting from the use or application of this equipment.

The examples and diagrams in this manual are included solely for illustrative purposes. Because of the many variables and requirements associated with any particular installation, Rockwell Automation, Inc. cannot assume responsibility or liability for actual use based on the examples and diagrams.

No patent liability is assumed by Rockwell Automation, Inc. with respect to use of information, circuits, equipment, or software described in this manual.

Reproduction of the contents of this manual, in whole or in part, without written permission of Rockwell Automation, Inc., is prohibited.

Documentation Feedback

Your comments will help us serve your documentation needs better. If you have any suggestions on how to improve this document, complete this form, publication [RA-DU002](#), available at <http://www.rockwellautomation.com/literature/>.

Rockwell Automation maintains current product environmental information on its website at <http://www.rockwellautomation.com/rockwellautomation/about-us/sustainability-ethics/product-environmental-compliance.page>.

Allen-Bradley, DH+, FactoryTalk, PanelView, Rockwell Software, and Rockwell Automation are trademarks of Rockwell Automation, Inc.
Trademarks not belonging to Rockwell Automation are property of their respective companies.

Rockwell Otomasyon Ticaret A.Ş., Kar Plaza İş Merkezi E Blok Kat:6 34752 İçerenköy, İstanbul, Tel: +90 (216) 5698400

www.rockwellautomation.com

Power, Control and Information Solutions Headquarters

Americas: Rockwell Automation, 1201 South Second Street, Milwaukee, WI 53204-2496 USA, Tel: (1) 414.382.2000, Fax: (1) 414.382.4444
Europe/Middle East/Africa: Rockwell Automation NV, Pegasus Park, De Kleetlaan 12a, 1831 Diegem, Belgium, Tel: (32) 2 663 0600, Fax: (32) 2 663 0640
Asia Pacific: Rockwell Automation, Level 14, Core F, Cyberport 3, 100 Cyberport Road, Hong Kong, Tel: (852) 2887 4788, Fax: (852) 2508 1846

Publication 2711P-TD001E-EN-P - March 2015

Supersedes Publication 2711P-TD001D-EN-P - February 2011

Copyright © 2015 Rockwell Automation, Inc. All rights reserved. Printed in the U.S.A.