

Panasonic

AC Servo Motor Driver MINAS A-series

Operating Manual



Be sure give this instruction manual to the user.

- Thank you very much for your buying Panasonic AC Servo Motor Driver,A-series.
- Before use, read through this manual to ensure proper use. Keep this manual at an easily accessible place so as to be referred anytime as necessary.

Table of Contents

Before Use

Safety Precautions	4	Parts Description	12
Introduction	8	Driver	12
• After Opening the Package	8	Motor	13
• Check the Model of Driver	8	Installation	14
• Check the Model of Motor	9	Driver	14
• Check the Combination of Driver and Motor	10	Motor	16

Preparations and Adjustments

System Configuration and Wiring	18	Trial Operation	50
• System Configuration and Wiring	18	Inspections before Trial Operation	50
• General Wiring Diagram		operation Without	
List of Available Components	20	Motor Load (JOG)	51
• Main Circuits	22	Operation With	
• CN SIG Connector		CN I/F Connected	52
(For Encoder)	24	Adjustments	55
• CN SER and		Purposes of Gain Adjustments	55
CN NET Connectors		Kinds of Gain Adjustments	55
(For PC or Controller)	27	How to Adjust Gain	57
• CN I/F Connector		How to Use	
(For Controller)	28	"NormalAuto-Gain" Tuning	58
(Circuits Available for Typical Control Modes)	29	How to Use "Real Time	
(Input and Output Signals, and their Functions)	32	Auto-Gain" Tuning	59
(Interface circuit)	38	How to Adjust Gain Manually	60
Parameter Setting	42		
Overview	42		
Parameter Groups and Listing	42		
Setting the Parameters	47		
MODEs Structure	48		

Important Information

Protective Functions	64	Troubleshooting	73
Maintenance and Inspections	71	After-Sale Service	Back cover

Appendixes



Conformance to EC Directives and UL Standards	App. 2	Overview of a Communication Control	App. 67
List of Connectable Motors	App. 7	Software PANATERM	App. 69
How to UseApp	App. 9	Optional Parts	App. 84
"Absolute" Driver	App. 20	Recommended Parts	App. 86
"Full Close" Driver	App. 28	Outer Views and Dimensions	App. 106
Details of Parameters	App. 30	Properties	App. 107
Details of Operation	App. 57	Specifications	

Safety Precautions



(Important)

Observe the following precautions in order to avoid injuries of operators and other persons, and mechanical damages.

The following DANGER and CAUTION symbols are used according to the level of dangers possibly occurring if you fail to observe the instructions or precautions indicated.

 DANGER	Indicates a potentially hazardous situation which, if not avoided, will result in death or serious injury.
 CAUTION	Indicates a potentially hazardous situation which, if not avoided, will result in minor or moderate injury and physical damage.

The following symbols indicate what you are not allowed to do, or what you must observe.

	This symbol indicates that the operation is prohibited.
	This symbol indicates that the operation must be performed without fail.

DANGER

An over-current protection, earth leakage breaker, over-temperature protection and emergency stop should be installed.



Failure to observe this instruction could result in electric shocks, injuries and/or fire.

Don't insert your hands in the driver.



Failure to observe this instruction could result in burns and/or electric shocks.

DANGER

Don't touch the rotating part of the motor in motion.

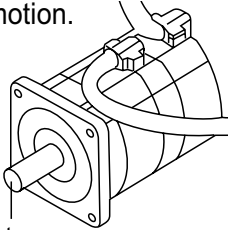

Rotating part

Failure to observe this instruction could result in injuries.

Don't subject the product to water splash, corrosive gases, flammable gases and combustible things.



Failure to observe this instruction could result in fire.

Do not expose the cables to sharp edges, excessive pressing forces, heavy loads or pinching forces.



Failure to observe this instruction could result in electric shocks, malfunction and/or damages.

Perform the transportation, wiring and inspection at least 10 minutes after the power off.



Failure to observe this instruction could result in electric shocks.

Ground the earth terminal of the driver.



Failure to observe this instruction could result in electric shocks.

Install an external emergency stop device so that you can shut off the power in any emergency cases.



Failure to observe this instruction could result in injuries, electric shocks, fire, malfunction and/or mechanical damages.

Caution

Use the motor and driver in the specified combination.



Failure to observe this instruction could result in fire.

Execute the trial operations with the motor fixed but without motor load connected. Connecting a load to the motor is possible only after successful trial operation.



Failure to observe this instruction could result in injuries.

If an error occurs, remove the causes for the error and secure the safety before restarting the operation.



Failure to observe this instruction could result in injuries.

Don't touch the motor, driver or its regenerative discharge resistor, since they become hot.



Failure to observe this instruction could result in burns.

Avoid extreme adjustment or change. Avoid an operation which causes unstable action.



Failure to observe this instruction could result in injuries.

Don't modify, dismantle or repair the driver.



Failure to observe this instruction could result in electric shocks and/or injuries.

Caution

Don't hold the cables or motor shaft when transporting the motor.



Failure to observe this instruction could result in injuries.

After recovery from the power failure, the equipment may restart suddenly. Don't approach to the equipment



during power failure.

*Provide appropriate settings as a preparedness against the accidental restart of the machine in order to ensure the safety of personnel.

Don't block the heat dissipation hole or insert foreign matters in it.



Failure to observe this instruction could result in electric shocks, injuries and/or fire.

Observe the voltage specified.



Failure to observe this instruction could result in electric shocks, injuries and/or fire.

Make sure that the wirings are made correctly.



Failure to observe this instruction could result in electric shocks, injuries.

This equipment should be treated as an industrial waste when it is disposed of.

When discarding batteries, insulate them with tapes or other similar means and obey the local rules.

Introduction

After Opening the Package

- After Opening the Package
- Make sure that the product is what you have ordered.

Check whether the product has been damaged or not during transportation.
If the product is not correct, or it has been damaged, contact dealer or sales agent.

Check the Model of Driver

Name plate

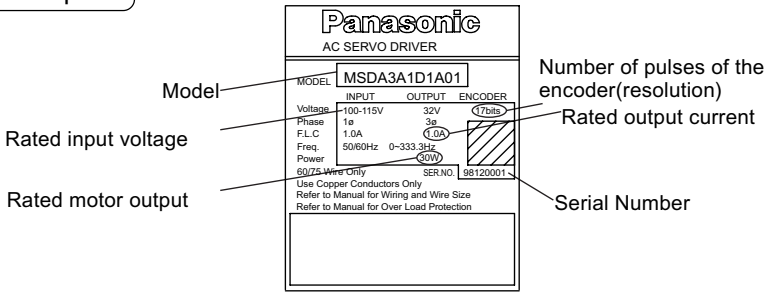

Model Designation

M S D A 0 4 3 A 1 A U U
 1~3 4 5~6 7 8 9 10 11~12

Applicable motors

Symbol	Applicable motors
MSD	MSM Low inertia
MDD	MDM Middle inertia
MHD	MHM High inertia
MFD	MFM Flat
MQD	MQM Flat & small
MGD	MGM Middle inertia

Series symbol
A: A-series

Power supply
1: Single-phase, 100V
3: Three-phase, 200V

Rated motor output (see Table 1-a)

Custom specification

Custom specification 2 (A, B, C...)

Custom specification 1 (1, 2, 3...)

Rotary encoder (see Table 1-b)

Introduction

Table 1-c Motor Structure

Oil seal	Brake	Shaft		
		Straight	Key way	D-cut
None	None	A	E	N
	Yes	B	F	P
None	None	C	G	Q
	Yes	D		R

"D-cut" shafts are available for MSMA30W to 750W and MQMA100W to 400W.

Check the Combination of Driver and Motor

The driver has been designed for use in combination with the specified motors only. Check the specifications (Series symbol, output rating, voltage rating and encoder type) of the motor you want to use.

With the incremental type encoder: 2500P/r

Amplifier	Amplifier type	Motor					
		Series symbol	Motor type	Voltage	Output rating	Revolution rating	Encoder type
MSDA3A1A1A	Type1	MSMA (Small)	MSMA3AZA**	100V	30W	3000r/min	Incremental 2500P/r, 11 wires
MSDA5A1A1A			MSMA5AZA**		50W		
MSDA011A1A			MSMA011A**		100W		
MSDA021A1A			MSMA021A**		200W		
MSDA041A1A	Type2	Low inertia	MSMA041A**	400W			
MSDA3A3A1A	Type1		MSMA3AZA**	30W			
MSDA5A3A1A			MSMA5AZA**	50W			
MSDA013A1A			MSMA012A**	100W			
MSDA023A1A		MSMA022A**	200W				
MSDA043A1A	Type2		MSMA042A**	400W			
MSDA083A1A	Type2		MSMA082A**	750W			
MSDA103A1A	Type4-2	MSMA (Large)	MSMA102A**	1.0kW	3000r/min	Incremental 2500P/r, 11 wires	
MSDA153A1A	Type4-3		MSMA152A**	1.5kW			
MSDA203A1A			MSMA202A**	2.0kW			
MSDA253A1A			MSMA252A**	2.5kW			
MSDA303A1A		Type5	Low inertia	MSMA302A**			3.0kW
MSDA353A1A	MSMA352A**			3.5kW			
MSDA403A1A	MSMA402A**			4.0kW			
MSDA453A1A	MSMA452A**			4.5kW			
MSDA503A1A	MSMA502A**			5.0kW			

With the absolute/incremental type encoder, 17 bits

Amplifier	Amplifier type	Motor									
		Series symbol	Motor type	Voltage	Output rating	Revolution rating	Encoder type				
MSDA3A1D1A	Type1	MSMA (Small)	MSMA3AZC**	100V	30W	3000r/min	With the absolute/ incremental type encoder, 17 bits				
MSDA5A1D1A			MSMA5AZC**		50W						
MSDA011D1A			MSMA011C**		100W						
MSDA021D1A	Type2	Low inertia	MSMA021C**		200W						
MSDA041D1A			MSMA041C**		400W						
MSDA3A3D1A	Type1	Low inertia	MSMA3AZC**		200V			30W	3000r/min		
MSDA5A3D1A			MSMA5AZC**	50W							
MSDA013D1A	Type2		MSMA012C**	100W							
MSDA023D1A			MSMA022C**	200W							
MSDA043D1A			MSMA042C**	400W							
MSDA083D1A	Type2		MSMA082C**	750W		3000r/min		Absolute/ incremental type, 17 bits, 7 wires See Note 2)			
MSDA103D1A	Type4-2	MSMA (Large)	MSMA102D**	1.0kW							
MSDA153D1A			MSMA152D**	1.5kW							
MSDA203D1A	Type4-3		MSMA202D**	2.0kW							
MSDA253D1A		MSMA252D**	2.5kW								
MSDA303D1A	Type5	Low inertia	MSMA302D**	200V	3.0kW		3000r/min				
MSDA353D1A			MSMA352D**		3.5kW						
MSDA403D1A			MSMA402D**		4.0kW						
MSDA453D1A			MSMA452D**		4.5kW						
MSDA503D1A			Type5		Low inertia				MSMA502D**	200V	5.0kW

< Notes >

- The above table shows the possible combinations between the driver (MSDA) and low-inertia type motors (MSMA). For middle-inertia (MDMA), high-inertia (MHMA), flat (MFMA), flat & small (MQMA) and middle-inertia (MGMA) motors, see the Appendix.
- The default is for "incremental" spec.
When you use the driver with the "absolute" spec, you need to;
 - Change the value of the parameter "Absolute encoder set-up (PROB)" from 1 (factory set default) to 0.
 - Install the battery (see Appendix "Optional Parts" for the batteries).
- The absolute/incremental spec driver can be used as "Full Closed Driver".

Parts Description

Driver

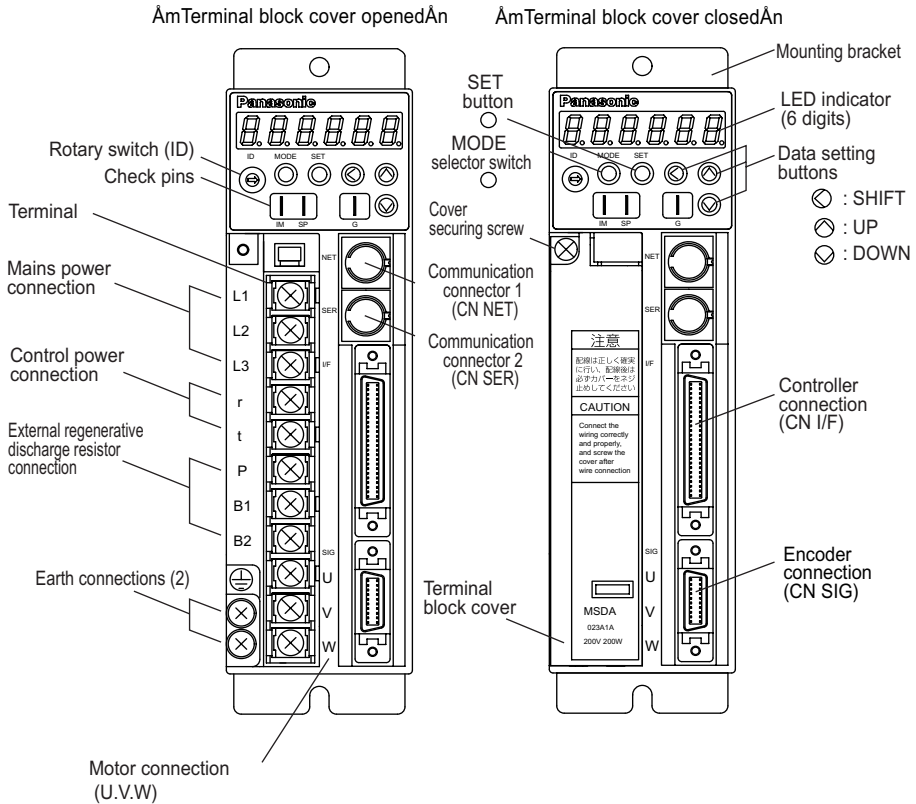

Example: MSDA023A1A (200V 200W: Type 1)

< Notes >

For detailed information for each of driver types, see the drawings in the Appendix.

Safe separation are provided between power board and control circuit.

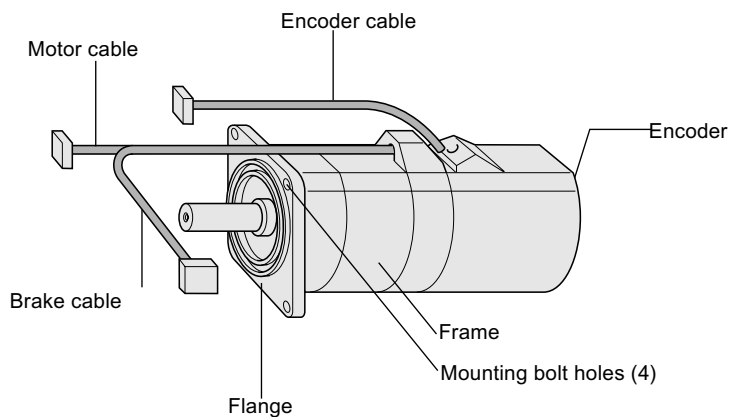

Example: Small Low-Inertia Motor (MSMA Series, 750W and below)

< Notes >

For detailed information for each of motor types, see the drawings in the Appendix.

Installation

The driver and motor should be properly installed to avoid failures, mechanical damages and injuries.

Amplifier

Location

- A Indoors, where the driver is not subjected to rain water and direct sun beams. Note that the driver is not a waterproof structure.
- B Avoid the place where the driver is subjected to corrosive gases, flammable gases, grinding liquids, oil mists, iron powders and cutting particles.
- C Place in a well-ventilated, and humid- and dust-free space.
- D Place in a vibration-free space.

Environmental Conditions

Item	Conditions
Ambient temperature	0 to 55°C (free from freezing)
Ambient humidity	Not greater than 90%RH (free from condensation)
Storage temperature	-20 to 80°C (free from condensation)
Storage humidity	Not greater than 90%RH (free from condensation)
Vibration	Not greater than 5.9m/s ² (0.6G) at 10 to 60 Hz
Altitude	Not greater than 1000 m

How to Install

- A This is a rack-mount type.

Place the driver vertically. Allow enough space surrounding for ventilation.

Type 3 and smaller (up to 750W): Back panel mount type (projected, use Bracket A)

Type 4 and larger (1kW and larger): Front panel mount type (recessed, use Bracket B)

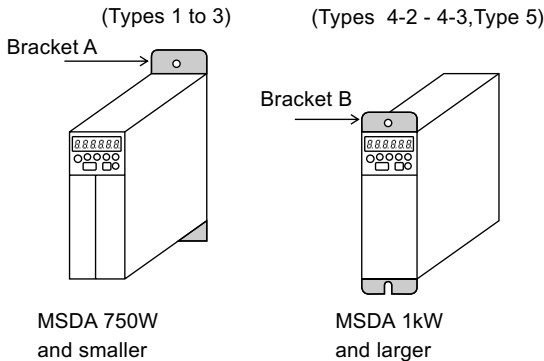

- B If you want to change the mounting configuration, use the optional bracket (see Appendix "Optional Parts").
- C Fit to noncombustibles such as metal.

Mounting Direction and Space Requirements

- Allow enough space to ensure enough cooling.
- Install fans to provide a uniform distribution of temperature in the control box.
- Observe the environmental requirements for the control box, mentioned in the previous page.

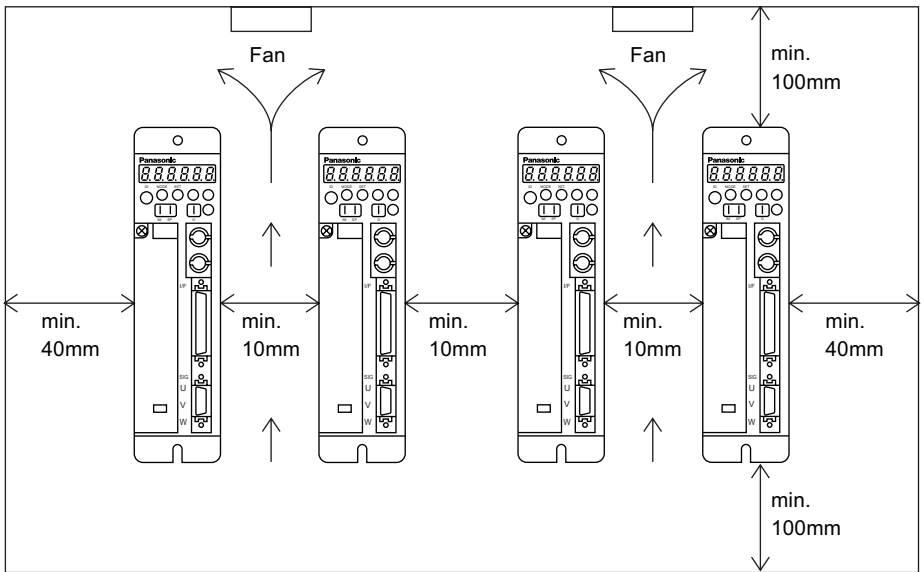

< Notes >

Conformance to UL Standard

Observing the following instruction makes this driver a UL508C standard authorized and EN50178 approved product.

1 Instructions in wiring

- 1) Use copper conductor wire with the rated temperature of 60°C or higher for wiring to terminal blocks or grounding terminals.
- 2) Be sure to connect the protective grounding of the control panel (PE) to a protective grounding terminal (⊕) of the driver to prevent electric shock. Do not double-connect to the protective grounding terminals (⊕). Two protective grounding terminals are provided.

2 Overload protection level

The overload protective function of the driver is activated when the effective current of the driver is 115% or more of the rated current. Make sure that the effective current of the driver does not exceed the rated current. The maximum allowable instantaneous current of the driver is the current set by the torque limit setting (Pr06).

3 Installation environment

Use the driver in environment with the pollution level 2 higher provided in IEC60664-1. For example, installing in a control panel of IP54 makes the pollution level of the environment 2. To achieve IP54, the structure shall not allow water, oil, carbon or dust to enter.

Installation

Motor

Location

- A Indoors, where the driver is not subjected to rain water and direct sun beams.
- B Avoid the place where the driver is subjected to corrosive gases, flammable gases, grinding liquids, oil mists, iron powders and cutting particles.
- C Place in a well-ventilated, and humid- and dust-free space.
- D Easy maintenance, inspections and cleaning is also important.

Environmental Conditions

Item	Conditions
Ambient temperature	0 to 40°C (free from freezing)
Ambient humidity	Not greater than 90%RH (free from condensation)
Storage temperature	-20 to 80°C (free from condensation)
Storage humidity	Not greater than 90%RH (free from condensation)
Vibration	Not greater than 49m/s ² (5G) in operation; not greater than 24.5m/s ² (2.5G) at rest

How to Install

The motor can be installed either vertically or horizontally. Observe the following notes.

A Horizontal mounting

- Place the motor with the cable outlet facing down to prevent the entry of oil and water.

B Vertical mounting

- If the motor is coupled with a reduction gear, make sure that the oil in the reduction gear does not enter into the motor.

Oil and Water Protections

- A This motor(IP65 rating) can be used where it is subjected to water and/or oil drops, but is not water or oilproof. Therefore, the motors should not be placed or used in such environment.
- B If the motor is coupled with a reduction gear, use the motor should with oil seals to prevent the reduction gear oil from entering into the motor.
- C Don't use the motor with the cables being immersed in oil or water.

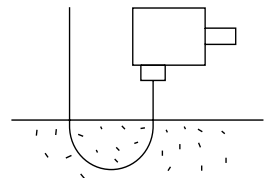

Cable: Stress Relieving

- A Make sure that the cables are not subjected to moments or vertical loads due to external bending forces or self-weight at the cable outlets or connections.
- B In case the motor is movable, secure the cable (proper one supplied together with the motor) to a stationery part (e.g. floor), and it should be extended with an additional cable which should be housed in a cable bearer so that bending stresses can be minimized.
- C Make the bending radius of cables as large as possible.

Permissible Shaft Load

- A Make sure that both of radial and thrust load to be applied to the motor shaft during installation and running, becomes within the specified value of each model.
- B Pay extra attention at installing a rigid coupling(especially an excess bending load which may cause the damages and/or wear of the shaft and bearings.
- C Flexible coupling is recommended in order to keep the radial load smaller than the permissible value, which is designed exclusively for servo motors with high mechanical stiffness.
- D For the permissible shaft load, see "Allowable Shaft Loads Listing" in Appendix.

Installation Notes

- A Don't hit the shaft with a hammer directly while attaching/detaching the coupling to the motor shaft.(otherwise the encoder at the opposite end of the shaft will be damaged).
- B Try perfect alignment between shafts (misalignment may cause vibration, and damages of the bearings).

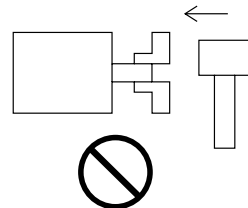

System Configuration and Wiring

General Wiring Diagram

Main Circuits

Non-Fuse Breaker (NFB)
Used to protect the power lines:
overcurrent will shutoff the circuit.

Noise Filter (NF)
Prevents the external noise from the power line, and reduces the effect of the noises generated by the servo motor.

Magnetic Contactor (MC)
Turns on/off the main power of the servo motor.
Used together with a surge absorber.

Reactor (L)
Reduces the harmonic in the main power.

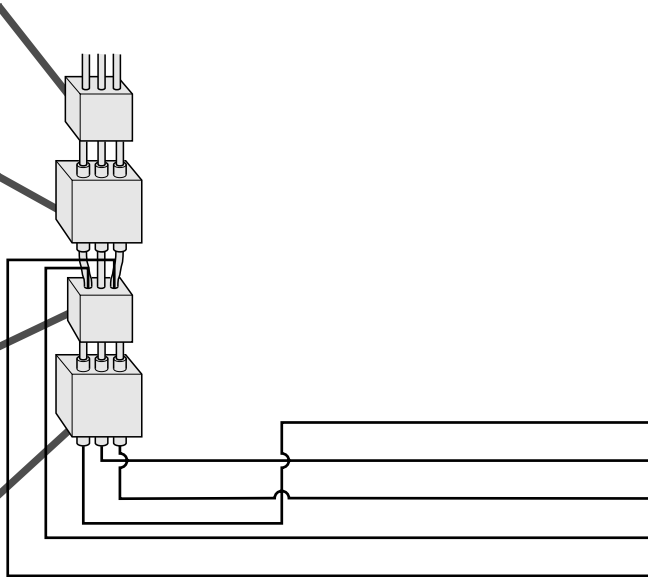

Motor cable:

- Without a brake
- With a brake

Terminals P, B1 and B2

- Normally keep B1 and B2 shorted.
 - If the capacity of the internal regenerative discharge resistor is not enough, disconnect between B1 and B2, and connect an external regenerative discharge resistor to P and B2 terminals.

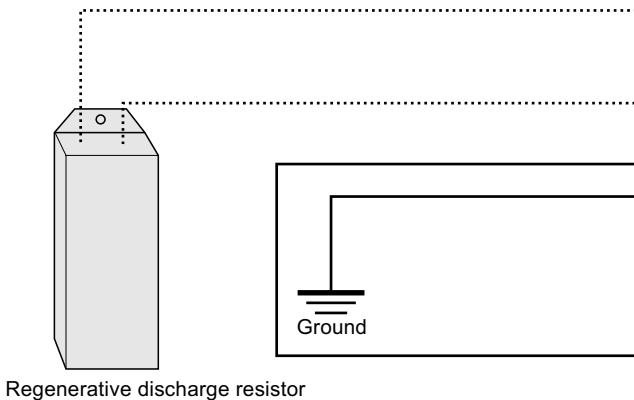

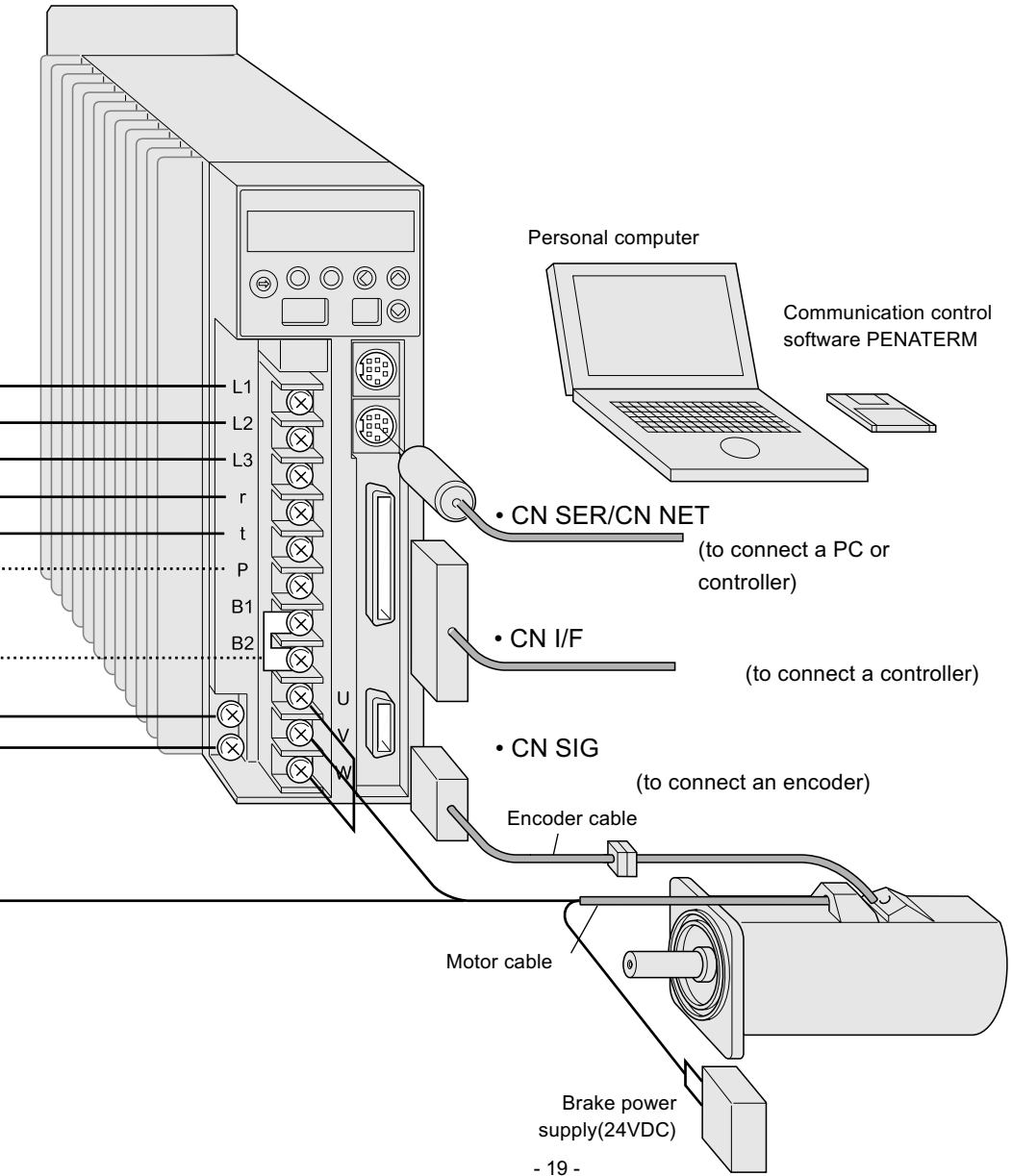

Personal computer

Communication control software PENATERM

• CN SER/CN NET

(to connect a PC or controller)

• CN I/F

(to connect a controller)

• CN SIG

(to connect an encoder)

Encoder cable

Motor cable

Brake power supply(24VDC)

System Configuration and Wiring

List of Available Components

Amplifier			Required Power (at the rated load)	Non-fuse breaker (rated current)	Noise filter	Magnetic contactor (contacts)	Main circuit wire diameter (L1, L2, L3, U, V, W and E)	Control power wire di- ameter (r and t)	Terminals on the terminalblock
Series	Voltage	Output							
MSDA	100V	30 - 50W	approx. 0.3kVA	BBP2-10 (10A)	LF-210	BMFT61041N (3P+1a)	0.75mm ² - 2.0mm ² A. W. G. 14`18	0.75mm ² A. W. G. 18	M4
MSDA MQDA		100W 200W	approx. 0.4kVA approx. 0.5kVA	BBP2-15 (15 A)	LF-215				
MSDA MQDA		400W	approx. 1.0kVA	BBP2-30 (30A)	LF-230	BMFT61541N (3P+1a)			
MSDA MQDA	200V	100W	approx. 0.3kVA	BBP3-5 (5A)	LF-305	BMFT61042N (3P+1a)	0.75mm ² - 2.0mm ² A. W. G. 18	0.75mm ² A. W. G. 18	M5
		200W 400W	approx. 0.5kVA approx. 0.9kVA	BBP3-10 (10A)	LF-310				
MSDA		750W	approx. 1.3kVA						
MGDA	200V	300W	approx. 0.7kVA	BBP3-10 (10A)	LF-310	BMFT61042N (3P+1a)	0.75mm ² - 2.0mm ² A. W. G. 18	0.75mm ² A. W. G. 18	M5
MFDA		400W	approx. 1.0kVA						
MHDA		500W	approx. 1.0kVA						
MGDA		600W	approx. 1.1kVA						
MDDA MFDA		750W	approx. 1.3kVA						
MGDA		900W	approx. 1.8kVA	BBP3-15 (15A)	LF-315	BMFT61542N (3P+1a)	2.0mm ² A. W. G. 14	0.75mm ² A. W. G. 18	M5
MSDA MDDA MHDA		1.0kW	approx. 2.3kVA	BBP3-20 (20A)	LF-320	BMFT61842N (3P+1a)			
MGDA		1.2kW							
MSDA MDDA MHDA MFDA		1.5kW							
MSDA MDDA MHDA		2.0kW	approx. 3.3kVA	BBP3-30 (40A)	LF-330	BMFT6252N (3P+2a2b)	2.0mm ² A. W. G. 14	0.75mm ² A. W. G. 18	M5
MGDA									

- When these wires are used, wire length between circuit breaker and driver should be less than 3m.
- Chose suitable wire size for Earthing Conductor which has some dimension as wire for power input and output.

Amplifier			Required Power (at the rated load)	Non-fuse breaker (rated current)	Noise filter	Magnetic contactor (contacts)	Main circuit wire diameter(L1, L2, L3, U, V, W and E)	control power wire diam- eter (r and t)	Terminals on the terminalblock
Series	Voltage	Output							
MSDA MDDA MFDA	200V	2.5kW	approx. 3.8kVA	BBP 3-40 (40A)	LF-340	B M F 6 3 5 2 N (3P+2a2b)	2.0mm ² A. W. G. 14	0.75mm ² A. W. G. 18	M5
MSDA MDDA MHDA		3kW	approx. 4.5kVA						
MGDA			approx. 5.3kVA						
MSDA MDDA MFDA		3.5kW		BBP 3-50 (50A)	LF-350	B M F 6 5 0 2 N (3P+2a2b)	3.5mm ² A. W. G. 11		
MSDA MDDA MHDA		4.0kW	approx. 6.0kVA						
MSDA MDDA MFDA		4.5kW	approx. 6.8kVA						
MGDA			approx. 7.5kVA						
MSDA MDDA MHDA		5kW			LF-360	B M F 6 6 5 2 N (3P+2a2b)			

- The model numbers of non-fuse breakers and magnetic contactors shown in the above list are manufactured by Matsushita Electric Works, Ltd.
- The model numbers of noise filters shown in the above list are manufactured by Tokin Corporation.

<Notes>

- When you use multiple drivers, determine the capacity of non-fuse breaker and noise filter according to the "total" required power capacity (net value determined by the actual loads) of the drivers.
- Terminal block and earth terminals
Wires should be copper conductors of a temperature rating of 60°C or above.
Screw tightening torque of larger than the allowable value (1.2 N-m for M4 and 2.0 N-m for M5) may damage the terminal.
- Earth wire diameter should be 2.0 mm² (AWG14) or larger for 30W to 2.5kW, and 3.5 mm² (AWG11) or larger for 3 to 5kW.

System Configuration and Wiring

Main Circuits

Don't turn on the main power until the wiring is completed, to avoid electric shocks.

Wiring Instructions

A Detach the terminal block by removing the cover securing screw.

B Make necessary connections.

Use clamp terminal connectors with an insulation cover. For wire diameter and connector sizes, see List of Available Components (page 20).

C Attach the terminal block cover and tighten the cover securing screw.

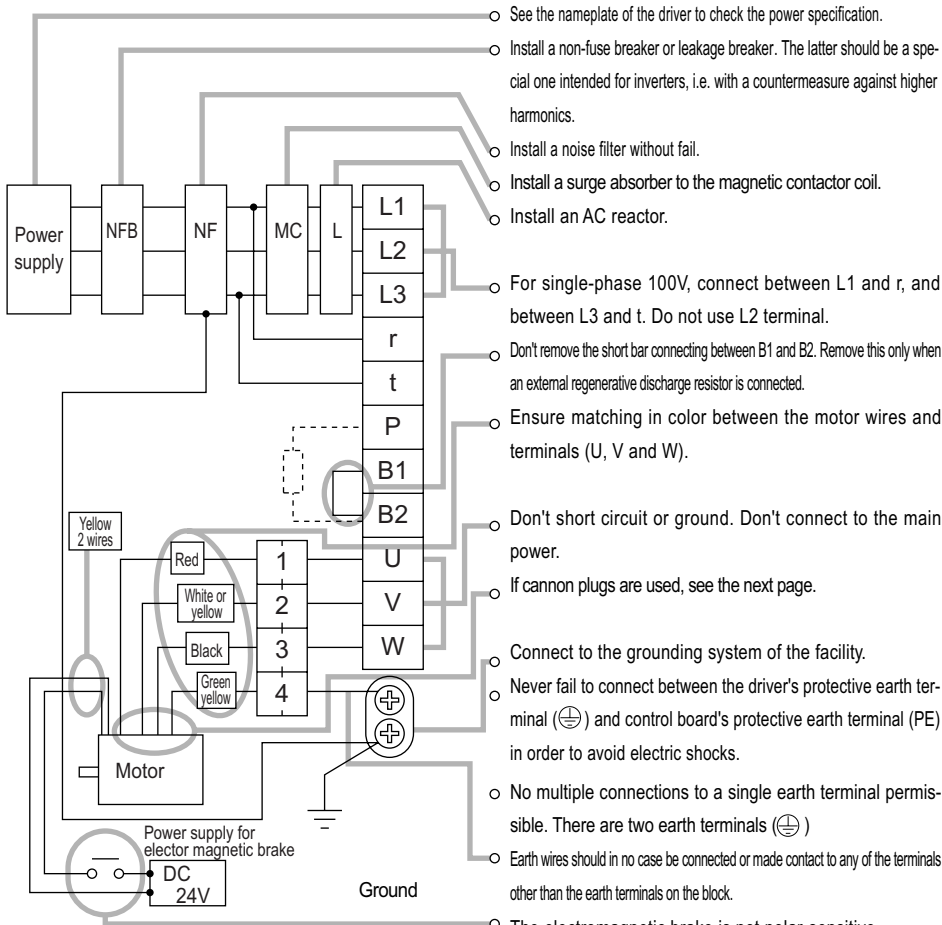

- See the nameplate of the driver to check the power specification.
- Install a non-fuse breaker or leakage breaker. The latter should be a special one intended for inverters, i.e. with a countermeasure against higher harmonics.
- Install a noise filter without fail.
- Install a surge absorber to the magnetic contactor coil.
- Install an AC reactor.
- For single-phase 100V, connect between L1 and r, and between L3 and t. Do not use L2 terminal.
- Don't remove the short bar connecting between B1 and B2. Remove this only when an external regenerative discharge resistor is connected.
- Ensure matching in color between the motor wires and terminals (U, V and W).
- Don't short circuit or ground. Don't connect to the main power.
- If cannon plugs are used, see the next page.
- Connect to the grounding system of the facility.
- Never fail to connect between the driver's protective earth terminal (⊕) and control board's protective earth terminal (PE) in order to avoid electric shocks.
- No multiple connections to a single earth terminal permissible. There are two earth terminals (⊕)
- Earth wires should in no case be connected or made contact to any of the terminals other than the earth terminals on the block.
- The electromagnetic brake is not polar-sensitive.
- For power capacities, see the Appendix (page 11).
- For use of the brake, see "Holding Brake" in page 9 of Appendix.

Wiring Diagrams

For 3-phase 200VAC

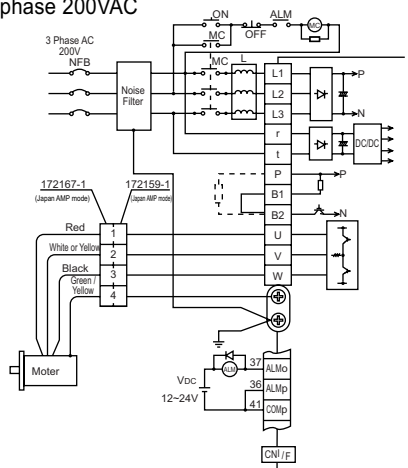

For 1-phase 100V

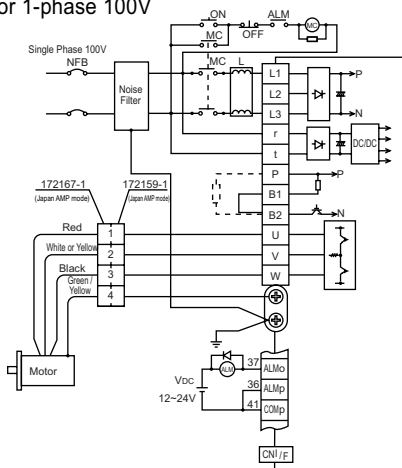

• Cannon Plug Type Motor Connectors

Motor			Cannon plug's pin no.					
Brake	Series symbol	Output rating	U	V	W	E	Brake 1	Brake 2
Not fitted	MSMA	1 ~ 2.5kW	A	B	C	D	—	—
	MDMA	0.75 ~ 2.5kW						
	MGMA	0.3 ~ 0.9kW						
	MHMA	0.5 ~ 1.5kW						
	MSMA	3 ~ 5kW	A	B	C	D	—	—
	MDMA	3 ~ 5kW						
	MGMA	1.2 ~ 4.5kW						
	MHMA	2 ~ 5kW						
MFMA	0.75 ~ 1.5kW	F	I	B	D, E	—	—	
MFMA	2.5 ~ 4.5kW	D	E	F	G, H	—	—	
Fitted	MSMA	1 ~ 2.5kW	F	I	B	D E	G	H
	MDMA	0.75 ~ 2.5kW						
	MGMA	0.3 ~ 0.9kW						
	MHMA	0.5 ~ 1.5kW						
	MFMA	0.4 ~ 1.5kW	D	E	F	G H	A	B
	MSMA	3 ~ 5kW						
	MDMA	3 ~ 5kW						
	MGMA	1.2 ~ 4.5kW						
	MHMA	2 ~ 5kW						
MFMA	2.5 ~ 4.5kW							

<Note> See "Cannon Plug (Optional)" in Appendix.

System configuration and wiring

CN SIG Connector (For Encoder)

Wiring Instructions

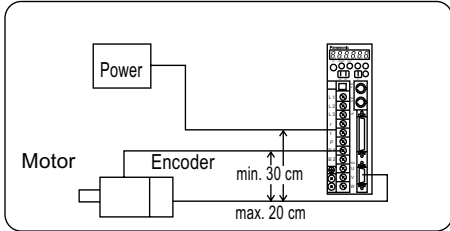

- The cable length between the driver and motor should be max. 20 m. If you use a longer cable, contact the dealer or sales agent.
- Separate these wiring min. 30 cm from the main circuit wires. Don't lay these wires in the same duct of the mains or bundle with them.

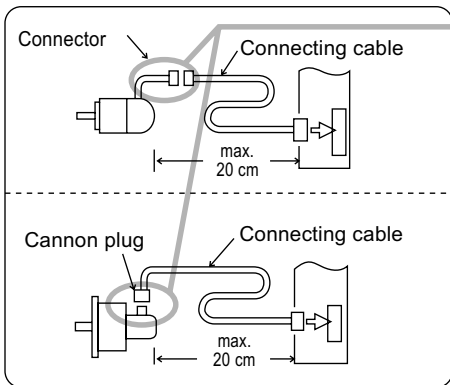

- Two types of encoder wire exit: One is "Lead wire + connector" and other is Cannon plug type (depending on the motor model).

- When you prepare your own connecting cables see the "Optional Parts" for connectors, and
 - 1) Follow the wiring diagram and use the
 - 2) Wire material: 0.18 mm² (AWG24) or above, shielded twist-paired wire with an enough bending durability,

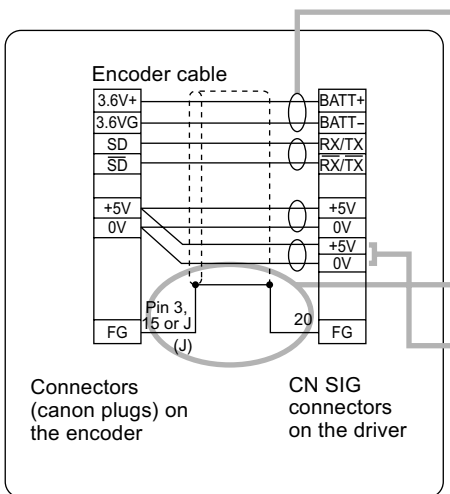

- 3) Signal/power paired wires should be of a twist-paired type.
- 4) Shield:
 - The shield at the driver side should be connected to Pin 20 (FG) of CN SIG Connector.
 - The shield at the motor side should be connected to:
 - Pin 3 (for AMP connector of 9 pins type)
 - Pin 15 (for AMP connector of 15 pins type)
 - J-pin (for canon plug connector)
- 5) If the cable is longer than 10 m, the encoder power line (+5V and 0V) should be dual per the figure shown left.
- 6) Other terminals should be left unconnected.

Wiring Diagrams (with a 2500P/r incremental type encoder ([A]*1)

- MSMA 750W or smaller, and MQMA

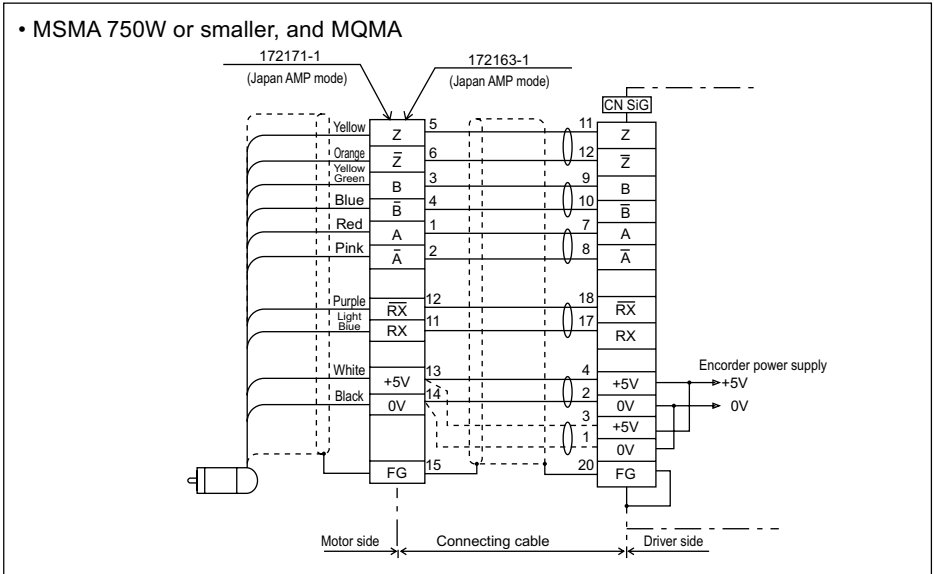

- MSMA 1kW or larger, MDMA, MFMA, MHMA and MGMA

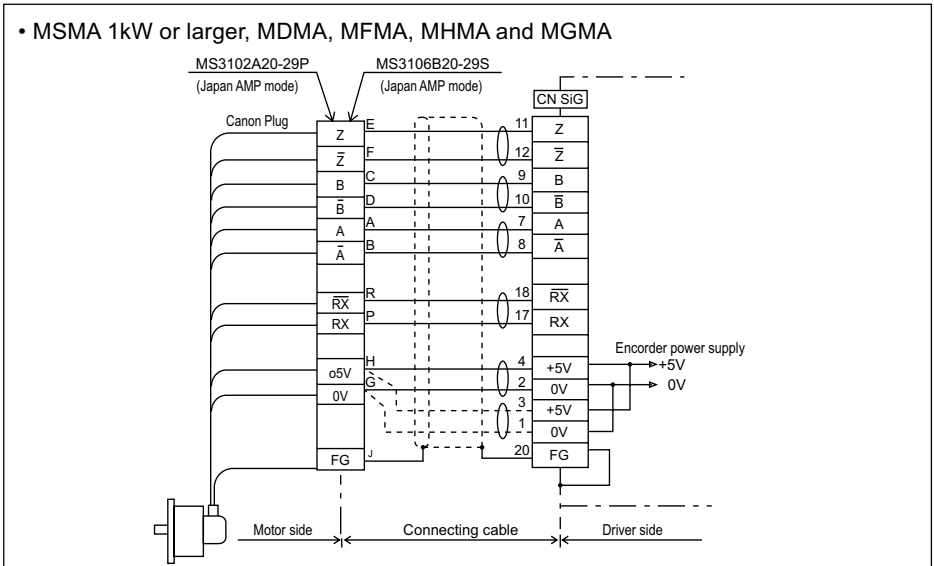

* 1 For encoder symbols, see Table 1-b in page 9.

⊗) shows a pair of twisted wires.

System configuration and wiring

Wiring Diagram

Driver with a 17 bits absolute encoder ([C]*1)

Driver with a 17 bits absolute/incremental encoder ([D]*1)

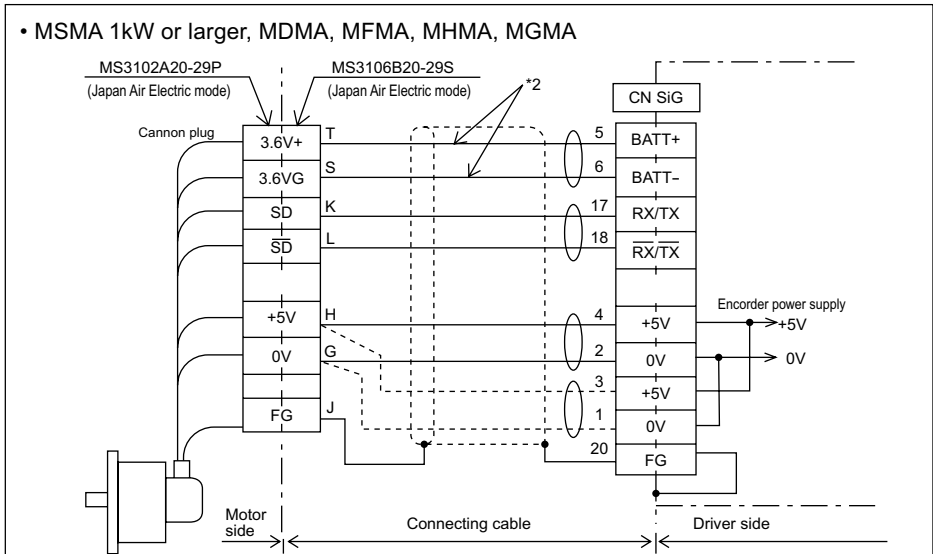
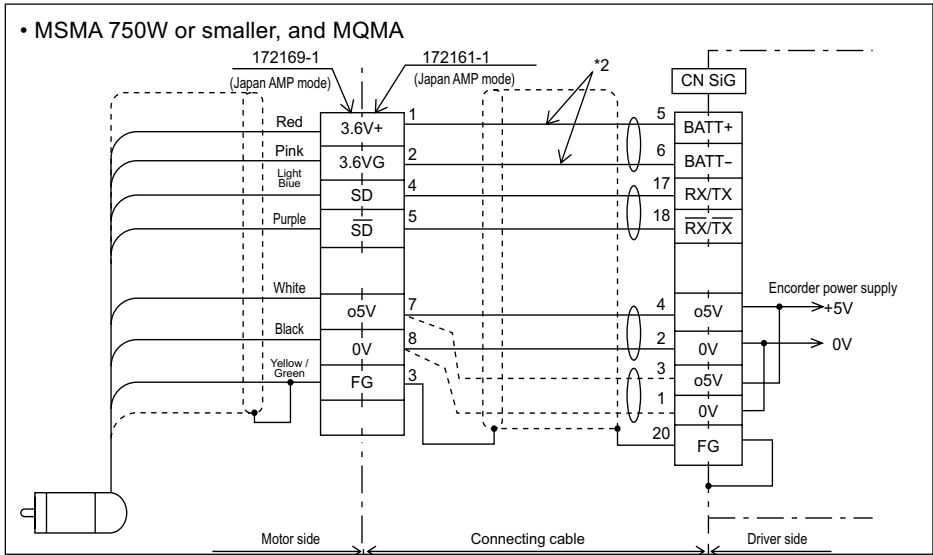

*2 If you use an absolute encoder ([C]) or absolute/incremental encoder ([D]) as an incremental encoder, you don't need to connect the back-up battery.

⊗ shows a pair of twisted wires.

CN SER and CN NET Connectors (For PC or Controller)

- These connectors can be used as either RS232C or RS485. There are three ways for using these connectors as shown below.

For RS232C communication only

Connect the personal computer and the driver 1:1 through RS-232C, The PANATERM using for communication control software. The PANATERM using this function the monitor of the personal computer settings wave graphics.

How to connect

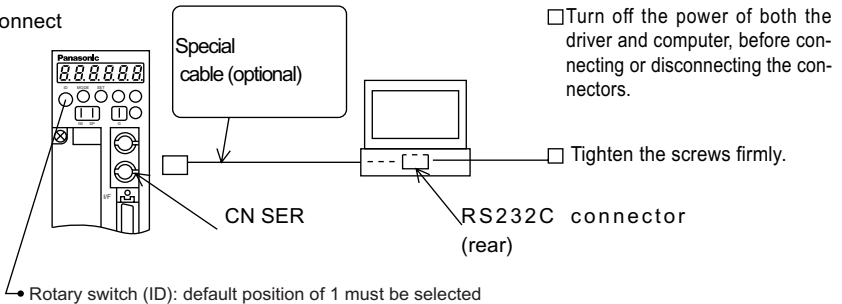

For both RS232C and RS485 communication

You connect the host and the 1st driver with RS232C, and connect the drivers in series with RS485.

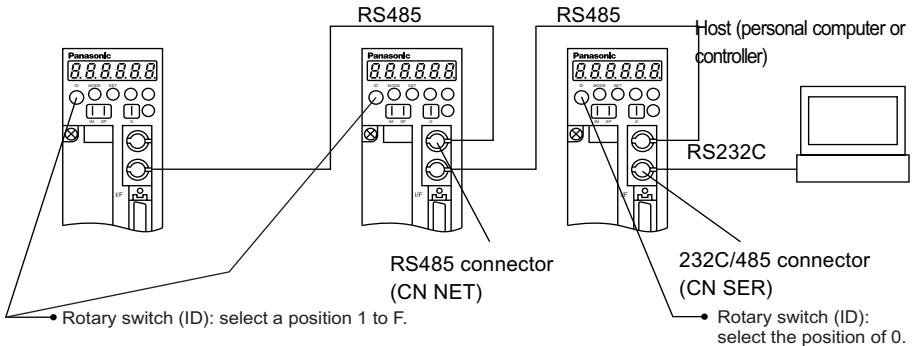

For RS485 communication only

Connect all the drivers and a host with RS485.

- Rotary switch (ID): select a position 1 to F.

< NOTE >

- Max. 15 drivers can be connected to a host.
- For detailed information, see Communication Specifications.

List of Available Components

CN I/F Connector (For Controller)

Wiring Instructions

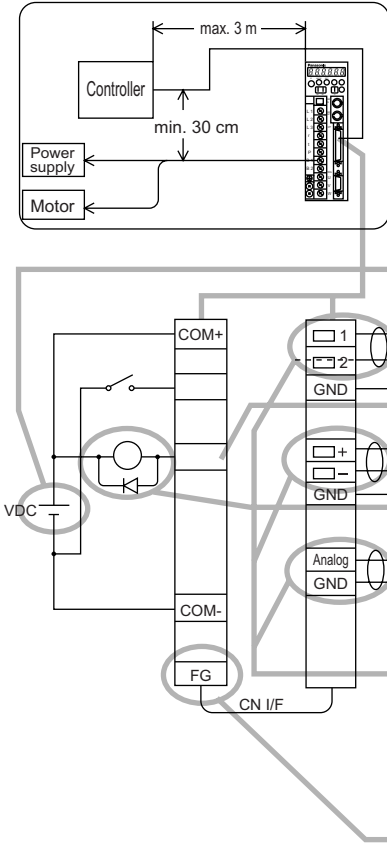

- Displace the peripheral devices such as the controller max. 3 m away from the driver.
- Separate these wiring min. 30 cm from the main circuit wires. Don't lay these wires in the same duct of the mains or bundle with them.
- The control power (VDC) between COM+ and COM- should be supplied by the customer (recommended voltage: +12VDC to +24VDC).
- Control signal output terminals can accept max. 24V or 50mA: Don't apply larger voltage or current exceeding these limits.
- If you directly activate a relay using the control signal, install a diode in parallel to the relay as shown in the left figure. Without a diode or with it but placed in the opposite direction, the driver will be damaged.
- Use a shielded twist-paired type for the wiring of pulse input, encoder signal output or analog command input.
- The Frame Ground (FG) is connected to an earth terminal in the driver.

• CN I/F Connector Specifications

Receptacle on the driver side	Connector to controller side		Manufacturer
	Part description	Part No.	
10250-52A2JL	Solder type plug	10150-3000VE	by Sumitomo 3M
	Shell	10350-52A0-008	

- The CN I/F pins assignment is shown in "Optional Parts" in Appendix.

Circuits Available for Typical Control Modes

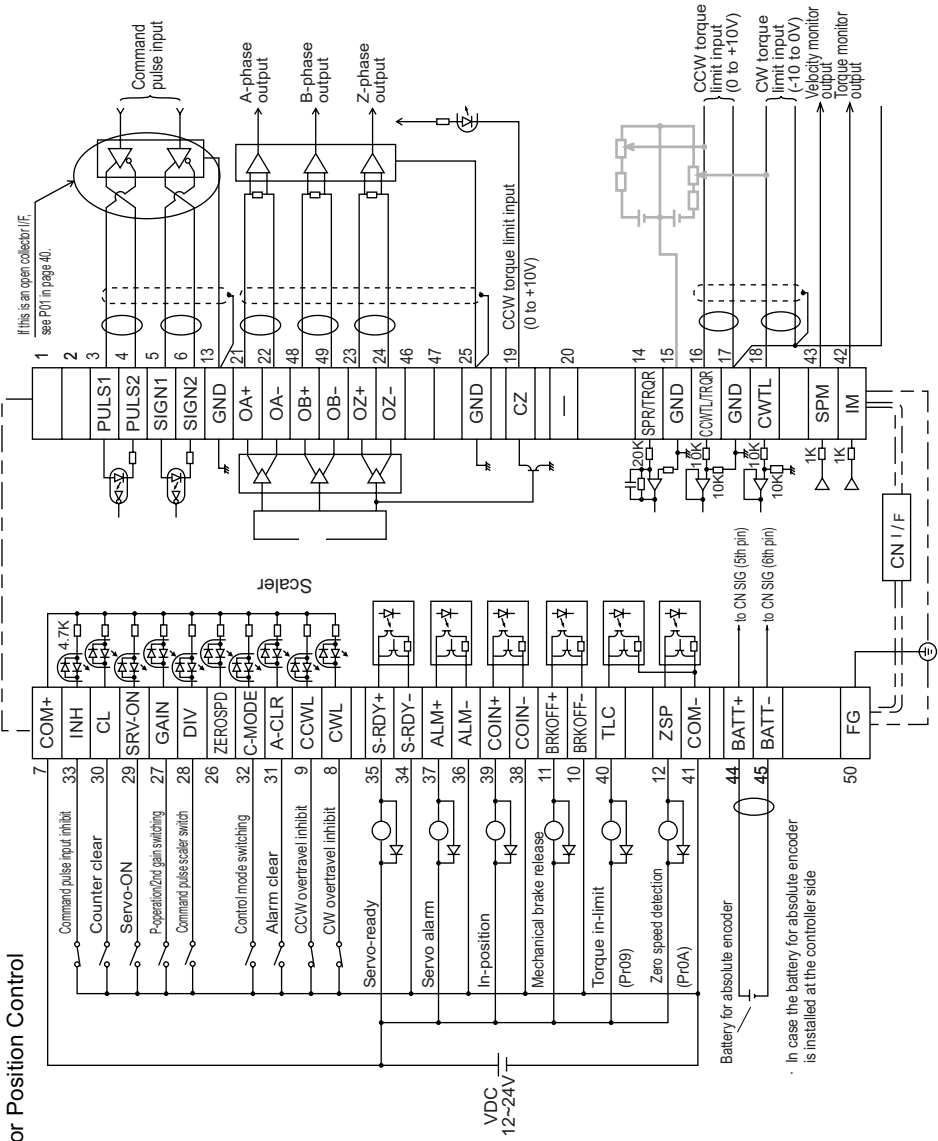

• CN 1/F Wiring for Position Control

System configuration and wiring

• CN I/F Wiring for Velocity Control

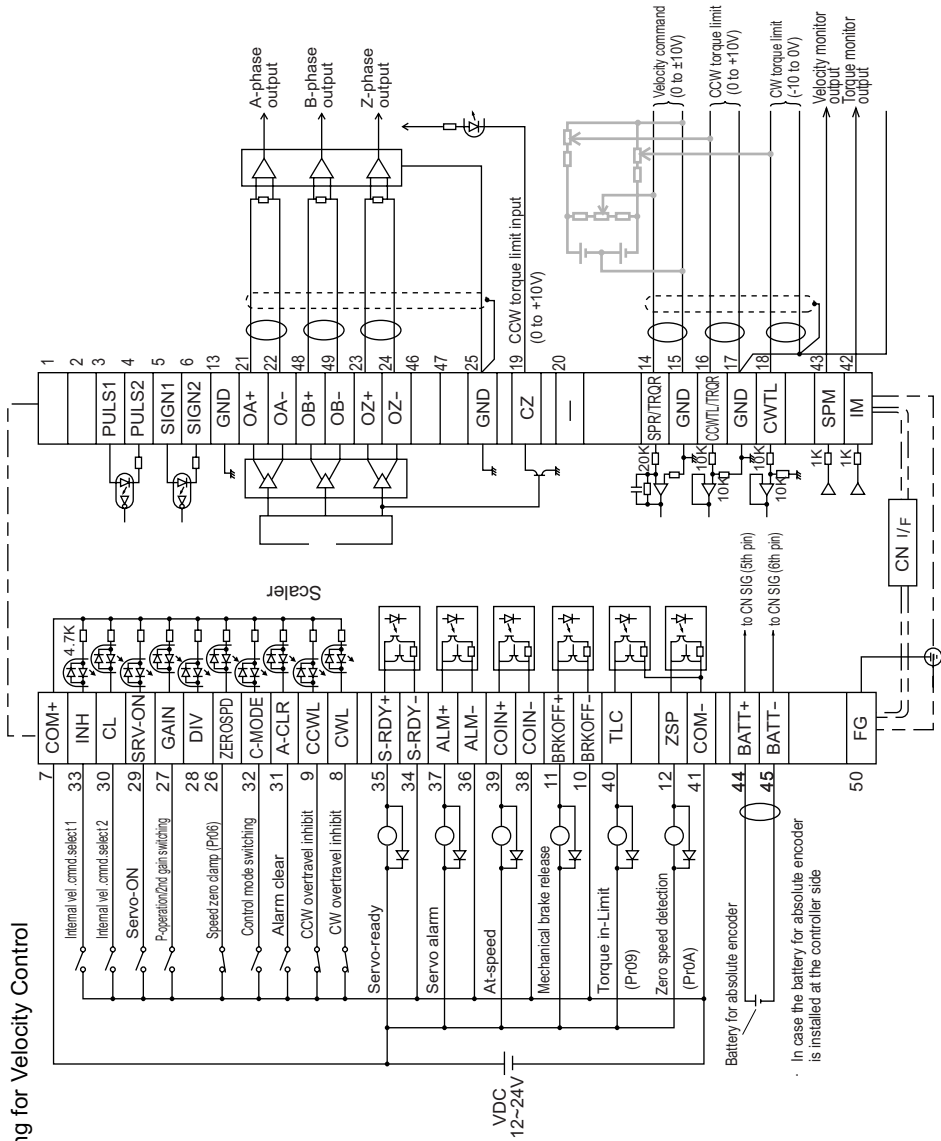

• CN I/F Wiring for Torque Control

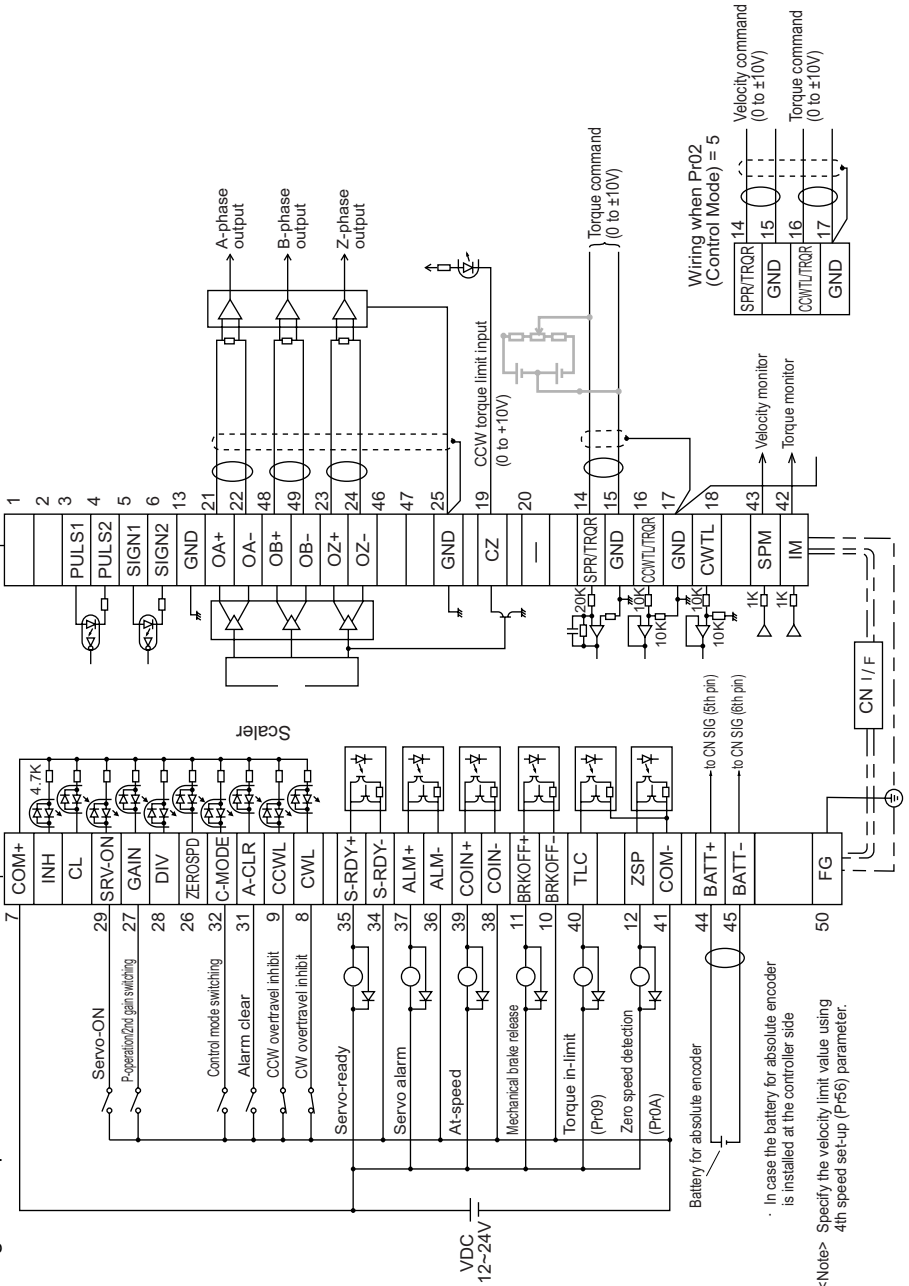

Wiring when PRO2
(Control Mode) = 5

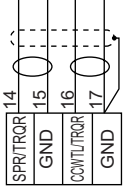

- In case the battery for absolute encoder is installed at the controller side
- <Note> Specify the velocity limit value using 4th speed set-up (P66) parameter.

System configuration and wiring

CN I/F Connector

Input Signals (Common) and their Functions

Signal	Pin No.	Symbol	Function	I/F circuit														
Control signal power (+)	7	COM +	<ul style="list-style-type: none"> Connect to (+) of an external power supply(12VDC to 24VDC). 	—														
Control signal power (-)	41	COM -	<ul style="list-style-type: none"> Connect to (-) of an external power supply(12VDC to 24VDC). The required capacity depends on the I/O circuit configuration. 0.5A or larger is recommended. 															
Servo-ON	29	SRV-ON	<ul style="list-style-type: none"> When this signal is connected to COM-, the dynamic brake will be released and the driver is enabled. (Servo-ON). <p><Notes></p> <ol style="list-style-type: none"> This signal becomes effective about two seconds after power on (see the Timing chart). Don't use this Servo-ON or Servo-OFF signal to turn on or off the motor. <ul style="list-style-type: none"> Allow at least 50ms delay after the driver is enabled before any command input is entered. By opening the connection to COM- , the driver will be disabled(Servo-OFF) and the current flow to the motor will be inhibited. Operation of the dynamic brake and clearing action of the position error counter can be selected using Pr69 (Sequence under Servo-OFF). 	SI page 38														
Control mode switching	32	C-MODE	<p>AEWhen Pr02 (Control Mode Selection) = 3, 4 or 5, the control mode is selected per the table below.</p> <table border="1"> <thead> <tr> <th>Pr02 value</th> <th>COM- open</th> <th>COM- closed</th> </tr> </thead> <tbody> <tr> <td>3</td> <td>(1st)</td> <td>(2nd)</td> </tr> <tr> <td>4</td> <td>Position control mode</td> <td>Velocity control mode</td> </tr> <tr> <td rowspan="2">5</td> <td>Position control mode</td> <td>Torque control mode</td> </tr> <tr> <td>Velocity control mode</td> <td>Torque control mode</td> </tr> </tbody> </table>	Pr02 value	COM- open	COM- closed	3	(1st)	(2nd)	4	Position control mode	Velocity control mode	5	Position control mode	Torque control mode	Velocity control mode	Torque control mode	SI page 38
			Pr02 value	COM- open	COM- closed													
			3	(1st)	(2nd)													
			4	Position control mode	Velocity control mode													
			5	Position control mode	Torque control mode													
Velocity control mode	Torque control mode																	
CW overtravel inhibit	8	CWL	<ul style="list-style-type: none"> If COM- is opened when the movable part of the machine has moved to CW exceeding the limit, the motor does not generate torque. 	SI page 38														
CCW overtravel inhibit	9	CCWL	<ul style="list-style-type: none"> If COM- is opened when the movable part of the machine has moved CCW exceeding the limit, the motor does not generate torque. When Pr04 (Overtravel Limit Input Disabled) = 1, CW and CCW inputs are disabled. The dynamic brake can be made operable during CW/CCW inputs valid. Use Pr66 (Dynamic Brake Inactivation at Overtravel Limit) to make the dynamic brake operable. 	SI page 38														

Signal	Pin No.	Symbol	Function	I/F circuit							
Counter clear	30	CL	The function differs depending on the control mode.	SI page 38							
			Position control		<ul style="list-style-type: none"> Clears the position error counter. Connect to COM- to clear the counter. Use Pr4D to select the clear mode (0 = Level, 1 = Edge) 						
			Velocity control		<ul style="list-style-type: none"> The internal speed selection 2 (input) is valid. Use this together with the INH signal (input). For details, see Pr05 (Velocity Set-Up Switching) description. 						
			Torque control		<ul style="list-style-type: none"> Invalid 						
Command pulse input inhibit	33	INH	The function differs depending on the control mode.	SI page 38							
			Position control		<ul style="list-style-type: none"> The command pulse input inhibit signal (input) is selected. This signal can be made disabled using Pr43. <table border="1" style="margin-left: 20px;"> <thead> <tr> <th>Pr43 value</th> <th>Meaning</th> </tr> </thead> <tbody> <tr> <td>1</td> <td>The INH signal (input) is disabled.</td> </tr> <tr> <td>0</td> <td> <ul style="list-style-type: none"> With COM- closed, the pulse command signal (PULSE SIGN) is enabled. With COM- open, the pulse command signal (PULSE SIGN) is inhibited. </td> </tr> </tbody> </table>	Pr43 value	Meaning	1	The INH signal (input) is disabled.	0	<ul style="list-style-type: none"> With COM- closed, the pulse command signal (PULSE SIGN) is enabled. With COM- open, the pulse command signal (PULSE SIGN) is inhibited.
			Pr43 value		Meaning						
			1		The INH signal (input) is disabled.						
0	<ul style="list-style-type: none"> With COM- closed, the pulse command signal (PULSE SIGN) is enabled. With COM- open, the pulse command signal (PULSE SIGN) is inhibited. 										
Velocity control	<ul style="list-style-type: none"> The internal command velocity selection 1 (input) is valid. Use this together with the CL signal (input). For details, see Pr05 (Speed Set-Up Switching) description. 										
Torque control	<ul style="list-style-type: none"> Invalid 										
Speed zero clamp	26	ZEROSPD	<ul style="list-style-type: none"> With COM- open, the velocity command is considered zero. This input can be made disabled using Pr06. <table border="1" style="margin-left: 20px;"> <thead> <tr> <th>Pr43 value</th> <th>Meaning</th> </tr> </thead> <tbody> <tr> <td>0</td> <td>ZEROSPD is disabled.</td> </tr> <tr> <td>1</td> <td>ZEROSPD is enabled</td> </tr> </tbody> </table>	Pr43 value	Meaning	0	ZEROSPD is disabled.	1	ZEROSPD is enabled	SI page 38	
			Pr43 value	Meaning							
			0	ZEROSPD is disabled.							
			1	ZEROSPD is enabled							

System configuration and wiring

Signal	Pin No.	Symbol	Function	I/F circuit		
Gain switching	27	GAIN	• The function depends on the value of Pr30.	SI page 38		
			Pr30 value		Connection to COM-	Function
			0		Open	Velocity loop: PI operation
					Close	Velocity loop: P operation
			1		Open	• 1st gain selected (Pr10, 11, 12, 13 and 14)
Close	• 2nd gain selected (Pr18, 19, 1A, 1B, 1C)					
		• No.2 Gain change Functions See Protective Adjustments on page 62.				
Alarm clear	31	A-CLR	<ul style="list-style-type: none"> • If the COM- connection is kept closed for more than 120 ms, the alarm status will be cleared. • For details, see Protective Functions on page 64. 	SI page 38		

Input Signals (Position Control) and their Functions

Signal	Pin No.	Symbol	Function	I/F circuit
Command pulse	3	PULS1	<ul style="list-style-type: none"> • This is the input terminal for command pulses. The driver receives this signal by a high-speed photo coupler. • The input impedance of PULSE and SIGN signals is 220Ω. • Command pulses can be input in three different ways. Use Pr42 to select one of the following. <ol style="list-style-type: none"> 1) Quadrature (A and B) input 2) CW (PULSE)/CCW (SIGN) pulse input 3) Command pulse (PULS)/Sign (SIGN) input 	PI page 38
	4	PULS2		
Command sign	5	SIGN1		
	6	SIGN2		
Command pulse scalar switch	28	DIV	<ul style="list-style-type: none"> • With COM- closed, the numerator of the command scalar is changed from the value stored in Pr46 (Numerator of 1st Command Scalar) to the value stored in Pr47 (Numerator of 2nd Command Scalar). <p>< Note > Don't enter command pulses 10 ms after or before switching.</p>	SI page 38
Battery +	44	BATT +	<ul style="list-style-type: none"> • Connect a backup battery for absolute encoder (pole-sensitive !). • If the battery is connected directly to the driver, it is not necessary to connect a battery to this terminal. 	—
Battery -	45	BATT -		

Input Signals (Velocity and Torque Control) and their Functions

Signal	Pin No.	Symbol	Function	I/F circuit
Velocity (torque) command	14 (15)	SPR/ TRQR (GND)	<p>< At velocity control ></p> <ul style="list-style-type: none"> This becomes velocity command input (analogue) You can set-up the relationship between the command voltage level and the motor speed, with Pr50 (Velocity Command Input Gain) . Use Pr51 to inverse the polarity of the command input. <p>< At torque control >*</p> <ul style="list-style-type: none"> This becomes torque command input (analogue) You can set-up the relationship between the command voltage level and the motor torque, with Pr5C (Torque Command Input Gain) . Use Pr5D to inverse the polarity of input signals. Use Pr56 (4th Speed Set-up) to adjust the speed limit in torque control. <p>< Note ></p> <p>SPR/TRQR are invalid in position control mode.</p>	AI page 39
CCW torque limit	16 (17)	CCWTL/ TRQR* (GND)	<p>< At velocity and position control ></p> <ul style="list-style-type: none"> You can limit the motor torque in the CCW direction by entering positive voltage (0 to +10V) to CCWTL. You can limit the motor torque in the CW direction by entering negative voltage (-10 to 0V) to CWTL. The torque limit value is proportional to the voltage with a factor of 100%/3V. CCWTL and CWTL are valid when Pr03 (Torque Limit Input Inhibit) = 0. They are invalid when Pr03 = 1. 	AI page 39
CW torque limit	18 (17)	CWTL (GND)	<p>< At torque control >*</p> <ul style="list-style-type: none"> Both of CCWTL and CWTL are invalid. Use the 4th. speed set-up(Pr56) to limit the speed. 	

* When the torque control mode is selected at the velocity/torque switching mode (Pr02 = 5), the No.16 pin (CCWTL/TRQR) becomes the torque command input (analogue). You can set-up the relationship between the command voltage level and the motor torque with Pr5C (Torque Command Input Gain).

System configuration and wiring

Output Signals (Common) and their Functions

Signal	Pin No.	Symbol	Function	I/F circuit	
Servo alarm	37 36	ALM + ALM -	• This output(transistor) turns OFF, when the driver detects and error(trip).	SO1 page 40	
Servo-ready	35 34	S-RDY + S-RDY -	• This output(transistor) turns ON, when the main power is on(for both the driver and the motor) and no alarm is active.	SO1 page 40	
Mechanical brake release	11 10	BRK-OFF + BRK-OFF -	• This output(transistor) turns ON , when the brake is released.	SO1 page 40	
Zero speed detection	12	ZSP	• Signal which is selected at Pr0A (ZSP Output Selection) will be turned on.s	SO2 page 40	
		Pr0A value	Signal symbol		Function
		0	TLC		Output(transistor) turns ON during the In-torque limiting.
		1	ZSP		Output(transistor) turns ON when the motor speed becomes lower than that of the preset speed with Pr61(Zero speed).
		2	WARN ALL		Output(transistor) turns ON when either one of over-regeneration, overload or battery warning is activated.
		3	WARN REG		Output(transistor) turns ON when the over-regeneration (more than 85% of permissible power of the internal regenerative discharge resistor) warning is activated.
		4	WARN OL		Output(transistor) turns ON when the overload (the effective torque is more than 85% of the overload trip level) warning is activated.
		5	WARN BATT		Output(transistor) turns ON when the battery (the voltage of the backup battery becomes lower than approx. 3.2V at the encoder side) warning is activated.
Torque in-limit	40	TLC	• Signal which is selected by Pr09 (TLC Output Selection) will be turned ON. • See the above ZSP signal for the set-up of Pr09 and functions.	SO2 page 40	
	39 38	COIN + COIN -			
In-position/At-speed		Control mode	Function	SO1 page 40	
		Position	Output(transistor) turns ON when the position error is below the preset value by Pr60 (In-Position Range).		
		Velocity and torque	Output(transistor) turns ON when the motor speed reaches the preset value by Pr62 (At-Speed).		

Signal	Pin No.	Symbol	Function	I/F circuit
A-phase output	21	OA +	<ul style="list-style-type: none"> Provides differential outputs of the encoder signals (A, B and Z phases) that come from the divider (equivalent to RS422 signals). The logical relation between A and B phases can be selected by Pr45 (Output Pulse Logic Inversion). Not insulated 	PO1 page 40
	22	OA -		
B-phase output	48	OB +		
	49	OB -		
Z-phase output	23	OZ +	<ul style="list-style-type: none"> Z-phase signal output in an open collector (not insulated) 	PO2 page 41
	24	OZ -		
Z-phase output	19	CZ		
Velocity monitor output	43	SP	<ul style="list-style-type: none"> Outputs the motor speed, or voltage in proportion to the commanded speed with polarity. + : CCW rotation - : CW rotation Use Pr07 (Velocity Monitor Selection) to switch between actual and commanded speed, and to define the relation between speed and output voltage. 	AO page 41
	(17)	(GND)		
Torque monitor output	42	IM	<ul style="list-style-type: none"> Outputs the output torque, or voltage in proportion to the position error with polarity. + : Fgenerating CCW-torque - : Fgenerating CW-torque Use Pr08 (Torque Monitor Selection) to switch between torque and positional error, and to define the relation between torque/positional error and output voltage. 	AO page 41
	(17)	(GND)		

Output Signals (Others) and their Functions

Signal	Pin No.	Symbol	Function	I/F circuit
Signal ground	13	GND	<ul style="list-style-type: none"> Signal ground in the driver Internally isolated from the control power (COM -). Internally connected to the earth terminal. 	—
	15			
	17			
	25			
Frame ground	50	FG	<ul style="list-style-type: none"> No connections should be made. 	—
(Not in use)	1	—		—
	2			
	20			
	46			
	47			

System configuration and wiring

CN I/F Connector

Interface Circuit (Input Circuit)

SI SI Connecting to sequence input signals

- Connect to a contact of switch and relay, or a transistor of an open collector output.
- Use a switch or relay for micro current so that insufficient contact can be avoided.
- Lower limit of the power supply (12 to 24V) should not be less than 11.4V in order to secure the appropriate level of primary current of the photo coupler.

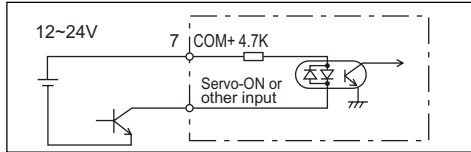
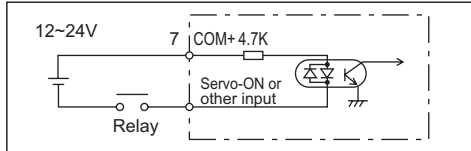

PI PI Command pulse input circuit

1) Line Driver I/F

- This is a good signal transmission method that is less sensitive to noises. We recommend you to use this to maintain the reliability of signals.

2) Open Collector I/F

- This uses an external control power supply(VDC).
- This requires a current-limiting resistor corresponding to the capacity of the VDC value.

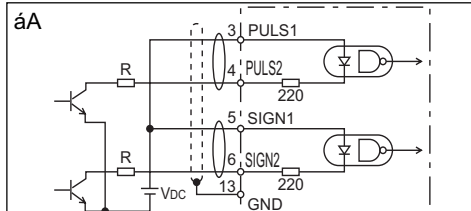
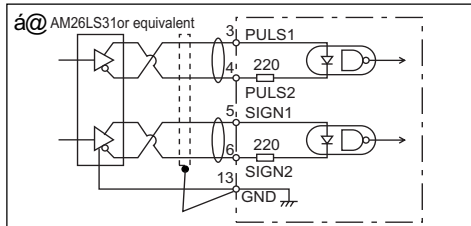

VDC	R value
12V	1kΩ 1/4W
24V	2kΩ 1/4W

$$\frac{V_{DC} - 1.5}{R + 220} = 10\text{mA}$$

 shows a pair of twisted wires.

AI Analogue Command Input

- There are three analogue command inputs of SPR/TRQQR (14 pins), CCWTL (16 pins) and CWTL (18 pins).
- The maximum permissible input voltage is $\pm 0V$. For the input impedance of these inputs, see the right figure.
- If you make a simplified circuit comprising a variable resistor (VR) and resistor (R), refer to the right figure.
When the variable range of each input is $-10V$ to $+10V$, the VR should be a B type resistor of $2k\Omega$ (min. $1/2W$). The R should be 200Ω (min. $1/2W$).
- The A/D converters for these inputs should have the following resolution.

- 1) ADC1 (SPR and TRQQR) : 16 bits (including one bit for sign)
- 2) ADC2 (CCWTL and CWTL) : 10 bits (including one bit for sign)

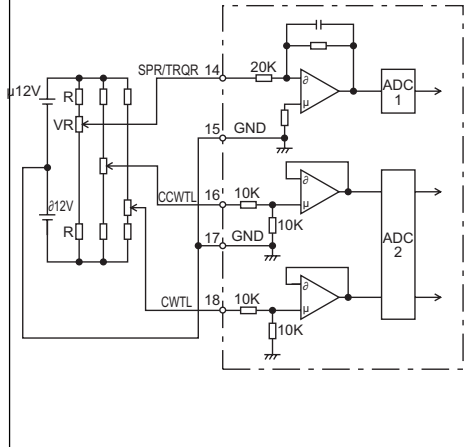

System Configuration and Wiring

Interface Circuit (Output Circuit)

SO1 SO2 Sequence output circuit

- This comprises a Darlington amplifier with an open collector. This is connected to a relay or photo coupler.
- here exists a collector-to-emitter voltage $V_{CE(SAT)}$ of approx. 1V at transistor ON, because of Darlington connection of the output transistor. Note that normal TTLIC can't be directly connected since this does not meet V_{IL} requirement.
- This circuit has an independent emitter connection, or a emitter connection that is commonly used as the minus (-) terminal (COM-) of the control power.
- The maximum rating is 30V, 50mA.

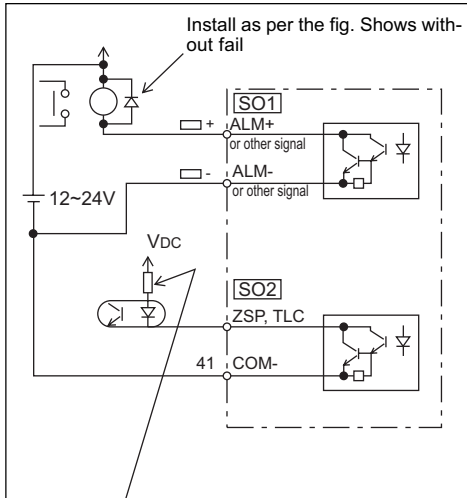

Calculate the value of R using the formula below so as the primary current of the photo coupler become approx. 10mA.

$$R = \frac{V_{DC} - 2.5}{1} \quad [K\Omega]$$

PO Line Driver (Differential Output) Output

- Provides differential outputs of encoder signals (A, B and Z phases) that come from the scalar.
- Receive these signals with a line receivers. In this case, install a resistor of approx. 330Ω between the inputs.
- These outputs are non-insulated signals.

 shows a pair of twisted wires.

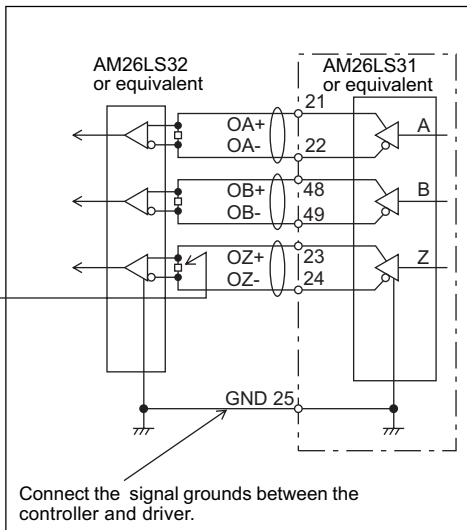

PO2 Open Collector Output

- Outputs Z-phase signals among those from the encoder. The outputs are non-insulated.
- Receive these signal with high-speed photo coupler at controller side, since these Z-phase signal width is normally narrow.

 shows a pair of twisted wires.

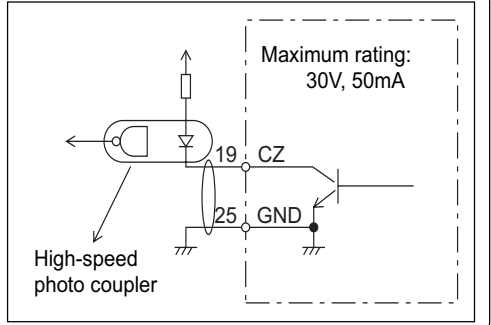

AO Analogue Monitor Output

- This output is the velocity monitor signal (SP) or torque monitor signal (IM).
- The signal range is approx. 0 to $\pm 9V$.
- The output impedance is $1k\Omega$. Pay attention to the input impedance of your measuring instruments and external circuits connected.

<Resolution>

- 1) Velocity monitor signal (SP): 8r/min./LSB calculated from $6V/3000r/min$ (Pr07 = 3)
- 2) Torque monitor signal (IM): 0.4%/LSB calculated from $3V/rated\ value$ (100%)

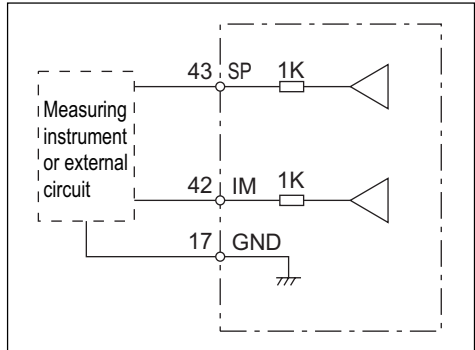

Parameter Setting

Overview

This driver has various parameters that are used for adjusting or setting the features or functions of the driver. This

section describes the purpose and functions of these parameters. Understanding these parameters is essential for

obtaining the best, application-specific operation of the driver.

You can view, set and adjust these parameters using either:

- 1) the front touch panel or
- 2) your personal computer with the communication software PANATERM .

Parameter Groups and Listing

Group	ParameterNo. Pr□□	Brief explanation
Function selection	00 ~ 0F	You can select the control mode, allocate I/O signals, and set the baud rate and etc.
Adjustment	10 ~ 1F	You can set various factors and constants such as the servo gains (1st and 2nd) for position, velocity and integration, and time constants of filters.
	20 ~ 2F	Real time auto-tuning parameters You can set the real time auto-tuning mode, select the machine stiffness, etc.
Position control	30 ~ 3F	You can set the parameters relating to the switching between 1st and 2nd gains.
	40 ~ 4F	You can set the input format of command pulses, logical selection, encoder pulse rate and pulse scalar.
Velocity and torque control	50 ~ 5B	You can set the input gain, polarity inversion and offset adjustment of velocity command. You can set the internal speed (1st to 4th and jog speed), and it's acceleration and deceleration time.
	5C ~ 5F	You can set the input gain, polarity inversion and offset adjustment of torque command and set the torque limit.
Sequence	60 ~ 6F	You can set the conditions for detecting of the output such as in-position and zero-speed, and set the processing conditions at excess position error, etc. You can also set the conditions for stopping at the main power-off, in-alarm and servo-off, or conditions for the error counter clearance, etc.
Full-close version	70 ~ 7F	"Full close" parameters. For details, see "Full-Close Specifications".

For details, see "Details of Parameters" in Appendix.

Parameters for Selecting Function

P : Position, S : Velocity, T : Torque

ParameterNO. (Pr □□)	Parameter description	Range	Default	Default	Related control mode
* 0 0	Axis address	0 ~ 15	1	—	P · S · T
* 0 1	Initial LED status	0 ~ 2	1	—	P · S · T
* 0 2	Control mode set-up	0 ~ 10	1	—	P · S · T
0 3	Analogue torque limit inhibit	0 ~ 1	1	—	P · S
0 4	Overtravel Input inhibit	0 ~ 1	1	—	P · S · T
0 5	Internal speed switching	0 ~ 2	0	—	S
* 0 6	ZEROSPD input selection	0 ~ 1	0	—	S
0 7	Speed monitor(SP) selection	0 ~ 9	3	—	P · S · T
0 8	Torque monitor (IM) selection	0 ~ 10	0	—	P · S · T
0 9	TLC output selection	0 ~ 5	0	—	P · S · T
0 A	ZSP output selection	0 ~ 5	1	—	P · S · T
* 0 B	Absolute encoder set-up	0 ~ 2	1	—	P · S · T
* 0 C	Baud rate set-up of RS232C	0 ~ 2	2	—	P · S · T
* 0 D	Baud rate set-up of RS485	0 ~ 2	2	—	P · S · T
0 E, 0 F	Internal use	—	—	—	—

Parameters for Adjusting Time Constants of Gain Filters, etc.

ParameterNO. (Pr □□)	Parameter description	Range	Default	Unit	Related control mode
1 0	1st position loop gain	10 ~ 2000	50	1/s	P
1 1	1st velocity loop gain	1 ~ 3500	<<100>>	Hz	P · S · T
1 2	1st velocity loop integration time constant	1 ~ 1000	50	ms	P · S · T
1 3	1st speed detection filter	0 ~ 5	4	—	P · S · T
1 4	1st torque filter time constant	0 ~ 2500	<<50>>	0.01ms	P · S · T
1 5	Velocity feed forward	0 ~ 100	0	%	P
1 6	Feed forward filter time constant	0 ~ 6400	0	0.01ms	P
1 7	(Internal use)	—	—	—	—
1 8	2nd position loop gain	10 ~ 2000	50	1/s	P
1 9	2nd velocity loop gain	1 ~ 3500	<<100>>	Hz	P · S · T
1 A	2nd velocity loop integration time constant	1 ~ 1000	50	ms	P · S · T
1 B	2nd speed detection filter	0 ~ 5	4	—	P · S · T
1 C	2nd torque filter time constant	0 ~ 2500	<<50>>	0.01ms	P · S · T
1 D	Notch frequency	100 ~ 1500	1500	Hz	P · S · T
1 E	Notch width selection	0 ~ 4	2	—	P · S · T
1 F	Disturbance torque observer	0 ~ 8	8	—	P · S · T

For values marked with << >>, see <Note> in page 44. For values marked with *, see page 46.

Parameter Setting

Parameters for Defining the Real Time Auto Gain Tuning

Parameter No. (Pr□□)	Parameter description	Range	Default	Unit	Related control mode
2 0	Inertia ratio	0 ~ 10000	<<100>>	%	P · S · T
2 1	Real time auto tuning set-Up	0 ~ 3	0	—	P · S · T
2 2	Machine stiffness at auto tuning	0 ~ 9	2	—	P · S · T
2 3	(Not available)				
24 ~ 2F	(Internal use)				

Parameters for Adjustments (for 2nd Gain)

Parameter No. (Pr□□)	Parameter description	Range	Default	Unit	Related control mode
3 0	2nd gain action set-up	0 ~ 1	0	—	P · S · T
3 1	Position control switching mode	0 ~ 8	0	—	P
3 2	Position control switching delay time	0 ~ 10000	0	166μs	P
3 3	Position control switching level	0 ~ 10000	0		P
3 4	Position control switching hysteresis	0 ~ 10000	0		P
3 5	Position loop gain switching time	0 ~ 10000	0	(1 + Setting value) x 166μs	P
3 6	Velocity control switching mode	0 ~ 5	0	—	S
3 7	Velocity control switching delay time	0 ~ 10000	0	166μs	S
3 8	Velocity control switching level	0 ~ 10000	0	—	S
3 9	Velocity control switching hysteresis	0 ~ 10000	0	—	S
3 A	Torque control switching mode	0 ~ 3	0	—	T
3 B	Torque control switching delay time	0 ~ 10000	0	166μs	T
3 C	Torque control switching level	0 ~ 10000	0	—	T
3 D	Torque control switching hysteresis	0 ~ 10000	0	—	T
3E ~ 3F	(Internal use)	—	—	—	—

For values marked with << >>, see <Note> in page 44.

<Note>

The following parameters have different default values depending on the Series of the Driver.

Parameter No. (Pr□□)	Default	
	Series MSDA and MQDA	Series MDDA, MFDA, MHDA and MGDA
1 1	100	50
1 4	50	100
1 9	100	50
1 C	50	100
2 0	100	0

Parameters for Position Control

P : Position, S : Velocity, T : Torque

Parameter No. (Pr□□)	Parameter description	Range	Default	Unit	Related control mode
* 4 0	Command pulse multiplier set-up	1 ~ 4	4	—	P
* 4 1	Command pulse logic inversion	0 ~ 3	0	—	P
* 4 2	Command pulse input mode set-up	0 ~ 3	1	—	P
4 3	Command pulse inhibit input invalidation	0 ~ 1	1	—	P
* 4 4	Output pulses per single turn	1 ~ 16384	2500	P/r	P · S · T
* 4 5	Pulse output logic Inversion	0 ~ 1	0	—	P · S · T
4 6	Numerator of 1st command pulse ratio	1 ~ 10000	<10000>	—	P
4 7	Numerator of 2nd command pulse ratio	1 ~ 10000	<10000>	—	P
4 8	Numerator of 3rd command pulse ratio	1 ~ 10000	<10000>	—	P
4 9	Numerator of 4th command pulse ratio	1 ~ 10000	<10000>	—	P
4 A	Multiplier of numerator of command pulse ratio	0 ~ 17	<0>	2 ⁿ	P
4 B	Denominator of command pulse ratio	1 ~ 10000	10000	—	P
4 C	Smoothing filter set-up	0 ~ 7	1	—	P
4 D	Counter clear input	0 ~ 1	0	—	P
4 E, 4 F	(Internal use)				

Parameters for Velocity and Torque Control

Parameter No. (Pr□□)	Parameter description	Range	Default	Unit	Related control mode
5 0	Velocity command input gain	10 ~ 2000	500	(r/min) / V	S · T
5 1	Velocity command input logic inversion	0 ~ 1	1	—	S · T
5 2	Velocity command offset	- 2047 ~ 2047	0	0.3mV	S · T
5 3	1st internal speed	- 10000 ~ 10000	0	r/min	S · T
5 4	2nd internal speed	- 10000 ~ 10000	0	r/min	S · T
5 5	3rd internal speed	- 10000 ~ 10000	0	r/min	S · T
5 6	4th internal speed	- 10000 ~ 10000	0	r/min	S · T
5 7	JOG speed set-up	0 ~ 500	300	r/min	P · S · T
5 8	Acceleration time set-up	0 ~ 5000	0	2ms/kr/min	S · T
5 9	Deceleration time set-up	0 ~ 5000	0	2ms/kr/min	S · T
5 A	S-shaped Accel./Decel. time set-up	0 ~ 500	0	2ms	S · T
5 B	(Internal use)	—	—	—	—
5 C	Torque command input gain	10 ~ 100	30	0.1V/100%	T
5 D	Torque command input inversion	0 ~ 1	0	—	T
5 E	Torque limit set-up	0 ~ 500	300	%	P · S · T
5 F	(Internal use)	—	—	—	—

For values marked with < > or *, see <Note> in page 46.

Parameter Setting

Parameters for Sequence

P : Position, S : Velocity, T : Torque

Parameter No. (Pr□□)	Parameter description	Range	Default	Unit	Related control mode
6 0	In-position range	0 ~ 32767	<10>	Pulse	P
6 1	Zero speed	0 ~ 10000	50	r/min	P • S • T
6 2	At-speed	0 ~ 10000	1000	r/min	S • T
6 3	Position error set-up	1 ~ 32767	<1875>	1/256Pulse	P
6 4	Position error invalidation	0 ~ 1	0	—	P
6 5	Undervoltage trip selection at main power-off	0 ~ 1	1	—	P • S • T
6 6	Dynamic Brake inhibition at overtravel limit	0 ~ 1	0	—	P • S • T
6 7	Sequence at main power-off	0 ~ 7	0	—	P • S • T
6 8	Sequence at alarm	0 ~ 3	0	—	P • S • T
6 9	Sequence at Servo-OFF	0 ~ 7	0	—	P • S • T
6 A	Mech. break action set-up at motor stadstill	0 ~ 100	0	2ms	P • S • T
6 B	Mech. break action set-up at motor in motion	0 ~ 100	0	2ms	P • S • T
* 6 C	External regenerative discharge resistor selection	0 ~ 2	0	—	P • S • T
6 D ~ 6 F	(Internal use)				

<Note>

The following parameters have different default values depending on the type of the encoder incorporated.

Parameter No. (Pr □ □)	Default	
	With the 2500P/r incremental encoder ([A])	With the 17 bits absolute encoder or absolute/incremental encoder ([C] or [D])
4 6	10000	1
4 7	10000	1
4 8	10000	1
4 9	10000	1
4 A	0	17
6 0	10	131
6 3	1875	25000

- To validate the parameters having a parameter number marked with *, set the parameters, then download them into EEPROM, then turn off the control power and then turn it on again.

Parameters (Pr70 to Pr7F) for "Full-Close" drivers

Pr70 ~ Pr7F

Refer to "Full-Close Specifications".

Setting the Parameters

• You can set the Parameters with;

- 1) the front touch panel or
- 2) A your personal computer with the A-series communication software PANATERM.

<Note>

For the use of PANATERM for parameter handling, see the instruction manual of the software.

• Using the front panel

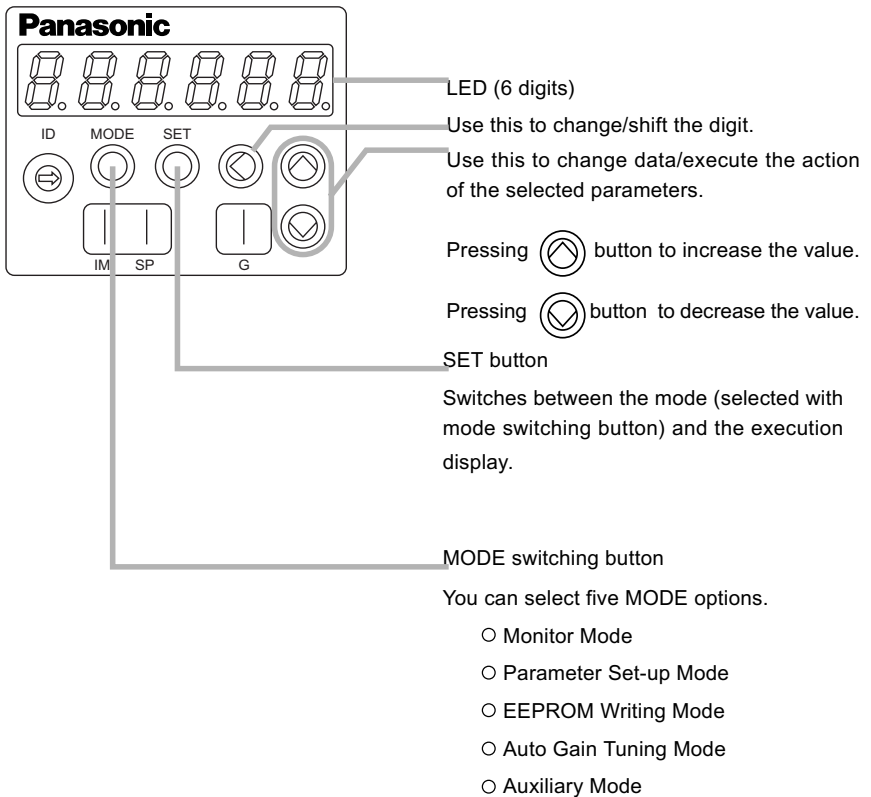

To set a parameter, select the Parameter Setting Mode.

Parameter Setting

MODE's Structure

You can select a desired MODE by using the front panel button.

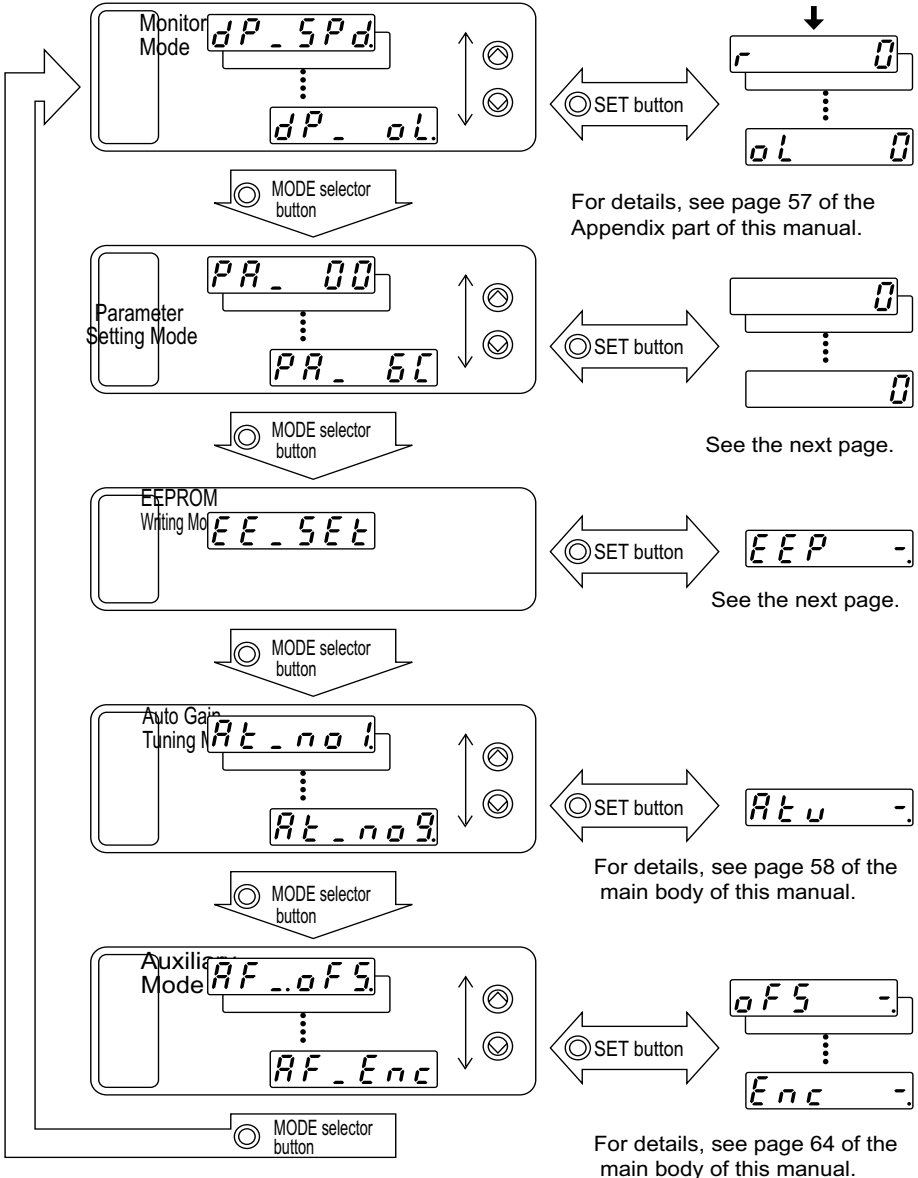

Using the front touch panel

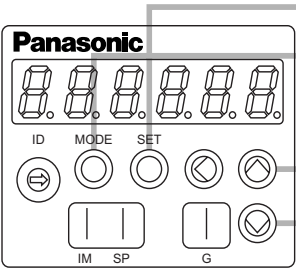

- 1) Turn the driver (power) ON.
- 2) ^{SET} Press SET button. PA_ 00
- 3) ^{MODE} Keep pressing MODE button. PA_ 10
- 4) Select your desired Parameter No. by using UP and DOWN button. 50
- 5) ^{SET} Press SET button. 100
- 6) Change the value using LEFT ARROW, UP and DOWN buttons.
- 7) ^{SET} Press SET button.

Select EPROM Writing Mode.

- 8) ^{MODE} Keep pressing MODE button EE_ SET
- 9) ^{SET} Press SET button. EEP -
↓
- 10) Keep pressing UP button (approx. 3 seconds). Bars in the display increases as shown in the right figure. EEP --
↓
- - - - -
↓

Start writing (momentary message will be displayed as shown in the right figure).

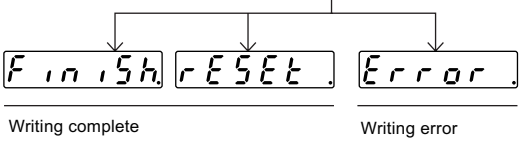

- If you set a parameter that will become valid after a reset operation, "RESET." will appear at writing complete. Turn off the power and then turn it on again to make the change valid.
 - You can re-write the parameter by keeping the UP button depressed at the parameter writing complete.
- <Notes>
- 1.If a writing error occurs, return to the first step of the writing procedure, and repeat it.
 - 2.Do not turn off the power during EEPROM writing. Otherwise a false data may be entered. If this happens, set all parameters again, make sure that all the parameter values are correct, and then write them down to EEPROM.

Trial Run

Inspections before Trial Run

1) Inspecting the wiring

- Make sure that all wire connections (especially main power and motor output) are correct.
- Make sure that there are no improper grounding connections, and earth wires are properly connected.

2) Inspecting the power specifications

- Make sure that the voltage is correct.

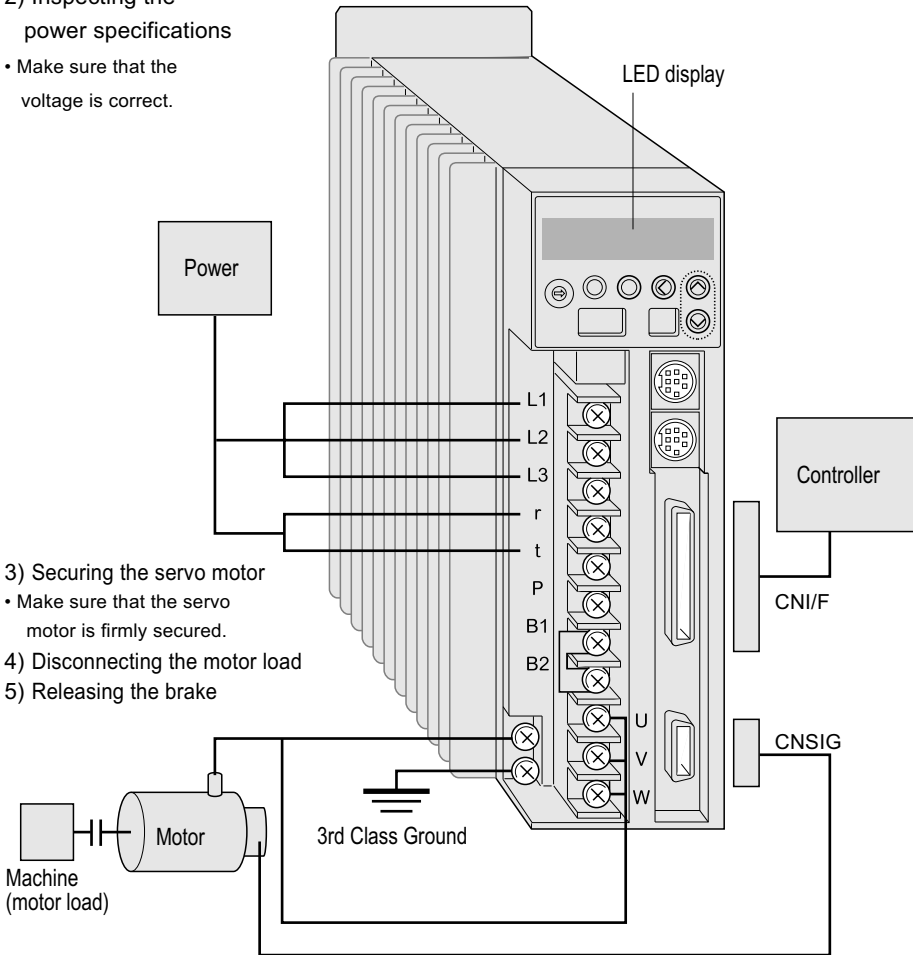

Trial Run without Motor Load (JOG)

Use the JOG function (run with the motor and driver alone) for trial run.

If the motor runs with this JOG, it means the motor and the driver are in good condition and so is the connection between them.

<Notes>

1. Disconnect the load from the motor and CN I/F, before executing the trial run.
2. Set the user parameters to the defaults (especially Pr10 (Position Gain) and Pr11 (Velocity Gain)) to avoid oscillation and other unfavorable behaviors.

Procedure

1) Turn ON the power (driver) .

→ r 0

Motor speed will be displayed (initial display)

2) Switch the parameter set-up(basis mode).

→ RF_JOG Call out.

3) Press SET button.

4) Keep pressing UP button until " r E A d y ." appears(see the fig. below)

- Keep pressing UP button (approx.3 seconds).
Bars increased as the rightfig. shows

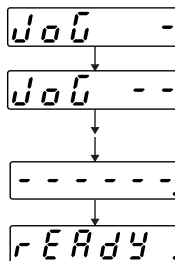

The trial run preparation is now complete.

5) Keep pressing LEFT ARROW button until " S r U . o n ." appears.

- Decimal point shifts from right to left by keep pressing LEFT ARROW button (approx. 3 seconds) as the right fig. shows.

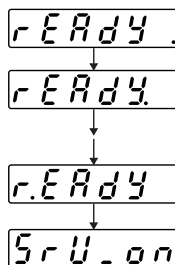

The secondary preparation is now complete.

5) The motor runs CCW by pressing UP button, and runs CW by pressing DOWN button, at the speed set by Pr57 (JOG speed set-up).

Trial Run

Operation With CN I/F Connected

- 1) Connect CN I/F.
- 2) Connect the control signal (COM+/-) to the power supply (12 to 24 VDC) .
- 3) Turn the main power (driver) ON.
- 4) Check the defaults of the parameters.
- 5) Connect between SRV-ON (CN I/F pin 29) and COM- (CN I/F pin 41) to make Servo-On active.
The motor will be kept excited.

Run at Position Control Mode

- 1) Set Pr42 (Command Pulse Input Mode Set-Up) according to the output form of the controller.
Then write it down to EEPROM. Then turn the power OFF and then ON again.
- 2) Send a low-frequency pulse signal from the controller to the driver to run the motor at low speed.
- 3) Check the motor speed at monitor mode.
 - Make sure that the speed is per the set-up.
 - Check if the motor stops when the command(pulse) is stopped.

Wiring Diagram

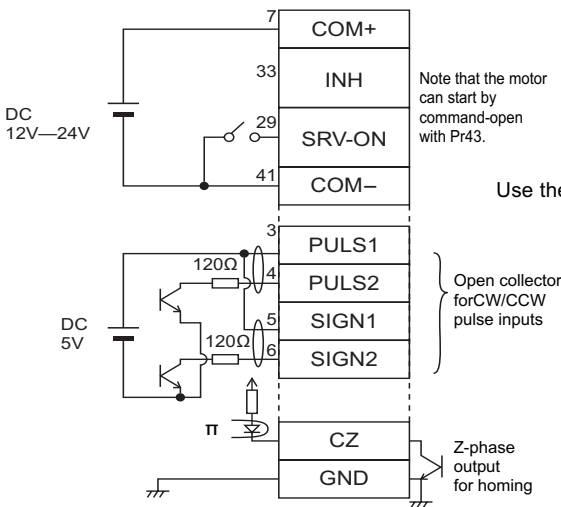

Parameters

PrNo.	Parameter description	Value
Pr02	Control mode set-up	0
Pr04	Overtravel input inhibit	1
Pr42	Command pulse input mode set-up	1
Pr43	Command pulse inhibit input invalidation	1

Use the controller to send command pulses.

Input Signals Status

No.	Input signal	Monitor display	
0	Servo-ON	+ A	
2	CW overtravel inhibit	—	
3	CCW overtravel inhibit	—	
8	Command pulse input inhibit	—	Related to Pr43
A	Counter clear	—	

Set-up of motor speed and input pulse frequency

Input pulse frequency (PPS)	Motor speed (r/min)	Pr 46 x 2 ^{Pr 4A} Pr 4B	
		17 bits	2500P/r
500K	3000	$\frac{1}{10000} \times 2^{17}$	$\frac{10000}{10000} \times 2^0$
250K	3000	$\frac{1}{5000} \times 2^{17}$	$\frac{10000}{5000} \times 2^0$
100K	3000	$\frac{1}{2000} \times 2^{17}$	$\frac{10000}{2000} \times 2^0$
500K	1500	$\frac{1}{10000} \times 2^{16}$	$\frac{5000}{10000} \times 2^0$

* You can set any value by setting any value for the numerator and denominator. However, the motor action will not follow the extreme setting of the ratio. It is recommended to set within a range from 1/50 to 20.

Relationship between motor speed and input pulse frequency

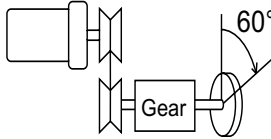

Pulley ratio: 18/60

Gear ratio: 12/73

Overall reduction: 18/365

(Example) Rotate the motor by 60 degrees with an overall reduction ratio of 18/365

		Encoder pulse			
		17 bits	2500P/r	2 ⁿ	10 Decimal
$\frac{\text{Pr46}}{\text{Pr48}} \times 2^{\text{Pr4A}}$		$\frac{365}{6912} \times 2^{10}$	$\frac{365}{108} \times 2^0$	2 ⁰	1
Theory	From the controller to the driver, enter a command with which the motor turns one revolution with 8192 (2 ¹³) pulses.		From the controller to the driver, enter a command with which the motor turns one revolution with 10000 pulses.	2 ¹	2
Determining the parameter	$\frac{365}{18} \times \frac{1A-2^{17}}{2^{13}} \times \frac{60^\circ}{360^\circ}$ $= \frac{365}{884736} \times 2^{17}$ <p>The numerator 47841280 is greater than 2621440, and the denominator is greater than 10,000. Thus,</p> $\frac{365}{18} \times \frac{1 \times 2^{10}}{2^6} \times \frac{60^\circ}{360^\circ}$ $= \frac{365}{6912} \times 2^{17}$		$\frac{365}{18} \times \frac{10000}{10000} \times \frac{60^\circ}{360^\circ}$ $= \frac{365}{108} \times 2^0$	2 ²	4
				2 ³	8
				2 ⁴	16
				2 ⁵	32
				2 ⁶	64
				2 ⁷	128
				2 ⁸	256
				2 ⁹	512
				2 ¹⁰	1024
				2 ¹¹	2048
				2 ¹²	4096
				2 ¹³	8192
				2 ¹⁴	16384
				2 ¹⁵	32768
				2 ¹⁶	65536
				2 ¹⁷	131072

Trial Run

Run at Velocity Control Mode

- 1) Apply a DC voltage between the velocity command input SPR (CN I/F pin 14) and GND (CN I/F pin 15). Increase the voltage gradually from 0, and make sure that the motor runs and the speed change accordingly.
- 2) Select the Monitor Mode to monitor the motor speed.
 - Make sure that the motor speed is as per the commanded speed.
 - Set the command to 0 to see if the motor stops.
- 3) If the motor still runs at very low speed, even the command voltage is set to 0, use the Auxiliary Mode to correct the voltage of command input (see Automatic Offset Adjustment function in Appendix).
- 4) To change the speed or direction, adjust the following parameters.
 - Pr50 (Velocity Command Input Gain)
 - Pr51 (Velocity Command Input Inversion)
 See "Details of Parameters" in Appendix

Parameters

PrNo.	Parameter description	Value	Default
Pr02	Control mode set-up	1	1
Pr04	Overtravel input inhibit	1	1
Pr06	ZEROSPD input selection	1	0
Pr50	Velocity command input gain	Set as required	500r/min/V
Pr58	Acceleration time set-up		0
Pr59	Deceleration time set-up		0
Pr5A	S-shaped accel/decel time set-up		0

Wiring Diagram

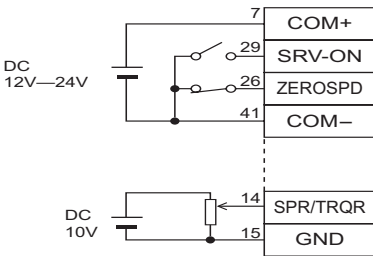

ZEROSPD switch
Close: Run
Open: Stop

One way operation

For two ways (CW and CCW) operation, use a bipolar power source.

Input Signal Status

No.	Input signal	Monitor display	
0	Servo-ON	+ A	
2	CW overtravel inhibit	—	
3	CCW overtravel inhibit	—	
5	Speed zero clamp	—	Stop with +A

Adjustments

Purposes of Gain Adjustment

In case of the servo motor, the motor is required to act per any command without any time delay, or without missing any commands. To ensure this, gain adjustment is necessary.

<Example: ball screw>

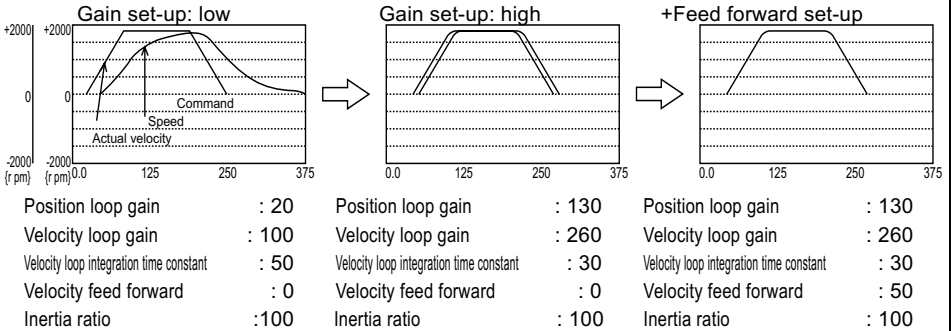

Preparations and Adjustments

Types of Gain Adjustment

Type		Description
Automatic adjustment	Normal mode auto gain tuning	Accelerate and decelerate the motor per the preset (internally fixed) patterns to calculate the load inertia from the required torque. Then automatically define appropriate gains according to the inertia.
	Real time auto gain tuning	During an actual operation, calculate the load inertia in real time. Then automatically define appropriate gains according to the inertia. The gains will be automatically adjusted against the fluctuation of load inertia during operation.
Manual adjustment	Manual gain tuning	You can manually adjust the necessary gains to obtain the most appropriate action by monitoring command to the driver, motor speed, torque and position error as the monitor signals(SP, IM), or using the optional communication software, PANATERM(especially with is graphic functi

Adjustments

Applicability of Automatic Adjustment

Item	Conditions
Load inertia	Must be at least three times as large as the motor inertia, but not greater than 20 times.
Load	<ul style="list-style-type: none"> • The machine (motor load) and its coupling must have a higher mechanical stiffness. • The backlash of the gears and other equipment must be small. • Eccentric load must be smaller than one-fourth of the rated torque. • The viscous load torque must be smaller than one-fourth of the rated torque. • Any oscillation must not cause any mechanical damages of the machine (motor load). • Two CCW turns and subsequent two CW turns must in no case cause any troubles.

The auto gain tuning affects the values of the following six parameters.

Pr10	1st Position Loop Gain	Pr13	1st Speed Detection Filter
Pr11	1st Velocity Loop Gain	Pr14	1st Torque Filter Time Constant
Pr12	1st Velocity Loop Integration Time Constant	Pr20	Inertia Ratio

- Pr15 (Velocity Feed Forward) will be automatically changed to 0%, if the auto gain tuning is executed.

<Notes>

The auto gain tuning will be disabled when you select a control mode using an external scale, i.e. Pr02 is set to 6, 7, 8, 9 or 10.

The real time auto gain tuning will be disabled in the following cases:

- 1) Running pattern at a constant speed
- 2) Running pattern with a small acceleration/deceleration

Relationship between Gain Adjustment and Mechanical Stiffness

To increase the mechanical stiffness,

- 1) The machine (motor load) should be firmly secured to a rigid foundation.
- 2) The coupling between the motor and machine should be a high-stiffness special one designed for servo motors.
- 3) The timing belt should have a larger width. The tension of the timing belt should be adjusted according to the allowable axial load of the motor.
- 4) The gears should have a smaller backlash characteristic.
 - The inherent frequency (resonance) of the machine significantly affects the gain adjustment of the servo motor. If the machine has a lower resonance frequency (i.e. lower stiffness), you can't set the high response of the servo system.

How to Adjust Gain

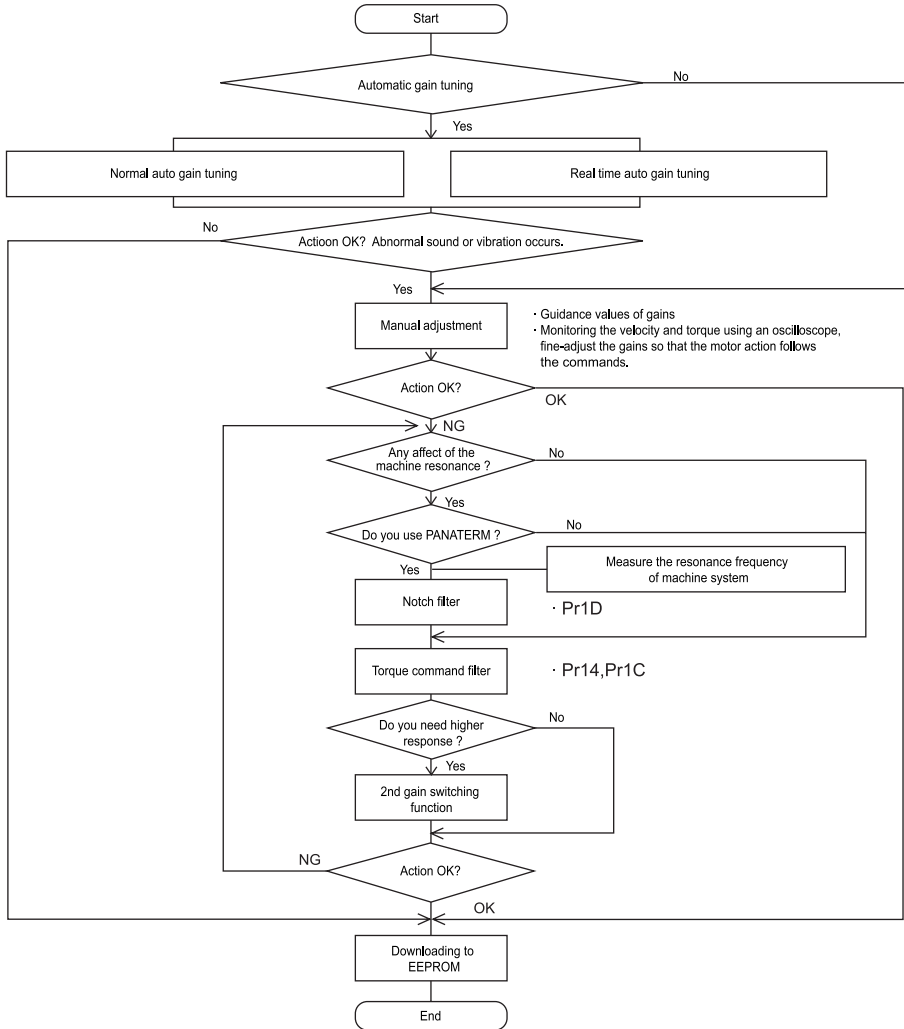

<Note>

- Pay extra attention to the safety.
- If the machine enter to oscillation (abnormal sound and vibration) , shut off the power immediately, or change to Servo-OFF.

Adjustments

How to Use "Normal Auto Gain Tuning"

1) Select the Normal Auto Gain Tuning

Mode.

Press SET button once and press

MODE switching button three times.

See page 48.

r 0

Motor speed display
(initial display)

At_no1

Mechanical stiffness
value

2) Press UP (⊕) or DOWN (⊖) button to select the stiffness of the machine.

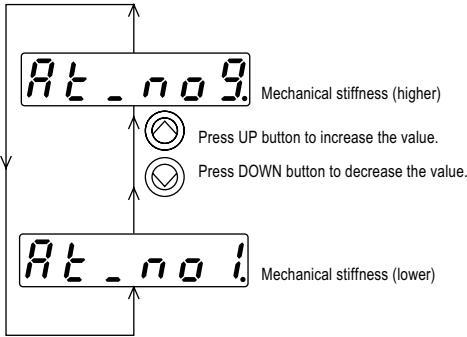

Driving method	Mechanical stiffness
Ball screw + direct coupling	4 ~ 8
Ball screw + timing belt	3 ~ 6
Timing belt	2 ~ 5
Gear, or rack & pinion	1 ~ 3
Others: lower stiffness	1 ~ 3

3) ^{SET} ⊙ Press SET button to turn to the monitor/execution mode.

4) Operation at the monitor/execution mode:

⊙ Keep pressing UP button until

START appears.

- CN I/F pin 29: Servo-ON
- Pr10 (Notch Frequency) = 1500

⊙ Keep pressing UP button
(approx. three seconds).

The horizontal bar increases as shown in the right figure.

Atu -

Atu --

START

FINISH

Error

The motor starts to run.

For approx. 15 seconds, the motor repeats the cycle 5 times(at most), which consists of two CCW revolutions

and two CW revolutions. Note that this process doesn't necessarily repeat 5 cycles and this is not abnormal.

5) Download the obtained gain values to EEPROM. Note that if you turn off the power before downloading, the gain values will be lost.

<Notes>

Symptom	Cause	Remedy
Error message displayed	Either one of Alarm, Servo-Off or Position Error Counter Clear activated.	<ul style="list-style-type: none"> • Avoid operation near the limit switch or home position sensor. • Turn to Servo-ON.
	The load inertia cannot be calculated	<ul style="list-style-type: none"> • Cancel the Position Error Counter Clear.
Values of gain affecting parameters (e.g. Pr10) doesn't change		Execute the manual adjustment.

How to Use "Real Time Auto-Gain" Tuning

- 1) Select the Parameter Set-up Mode.
- 2) Set Pr1F (Disturbance torque observer) to 8 (invalid).
- 3) Set Pr22 (Real time auto tuning machine stiffness).

First, set the parameter to the smallest value and then gradually increase it up to a with which no abnormal sound or vibration will occur.

Driving method	Mechanical stiffness
Ball screw + direct coupling	4 ~ 8
Ball screw + timing belt	3 ~ 6
Timing belt	2 ~ 5
Gear, or rack & pinion	1 ~ 3
Others: lower stiffness	1 ~ 3

- 4) Set Pr21 (Real time auto tuning mode set-up) to 1 or 2.
 - The operation may not be stable depending the operation pattern. In this case, set the parameter to 0 (to disable the auto tuning function).

Pr21 value	Real time auto tuning set-up	Fluctuation of load inertia during operation
0	Disabled	—
1	Enabled	Almost no change
2		Small change
3		Quick change

- With a larger value, the response to the change in load inertia (acceleration) is quicker.

- 5) Start the motor.
- 6) If the fluctuation in load inertia is small, stop the motor (machine), and set Pr21 to 0 to fix the gain (in order to raise the safety).
- 7) Download the obtained gain values to EEPROM. Note that if you turn off the power before downloading, the gain values will be lost.

<Notes>

- Before changing Pr21 or Pr22, stop (servo-lock) the motor.
- Don't modify Pr10 through Pr15.
- Otherwise it may give a shock to the machine.

Adjustment

How to Adjust Gain Manually

Before Adjustment

You may adjust the gains by viewing or hearing the motions and sound of the machine during operation. But, to adjust the gains more quickly and precisely, you can obtain quicker and secure adjustment by analog wave form monitoring.

1. Using the analogue monitor output

You can measure the actual motor speed, commanded speed, torque, position error in analog voltage level with an oscilloscope. To do this, it is necessary to specify the types of output signals and output voltage level by using Pr07 (Velocity monitor selection), Pr08 (Torque monitor selection). For details, see "CN I/F Connector" in the main part of this manual, and "Details of Parameters" in Appendix.

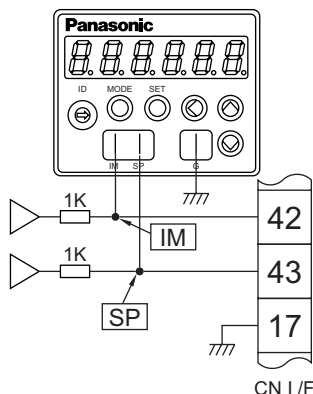

2. Wave form graphic function of PANATERM

You can view the graphic information of the command to the motor, actual motor action (speed, torque and position error) on the computer display screen. For details, see the instructions of PANATERM.

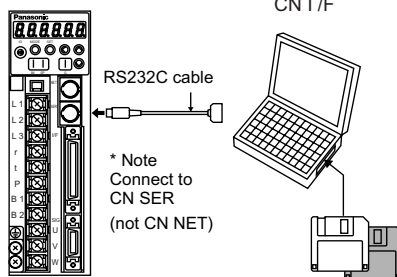

Guidance Values of Gains, and How to Adjust

See the table below for the guidance values of gains, if the inertia ratio has been set correctly.

Machine	Position loop gain Pr10	Velocity loop gain Pr11	Velocity loop integration time constant Pr12
Ball screw	100 ~ 150	200 ~ 300	100 ~ 150
Timing belt	50	100 ~ 200	50
Rack & pinion	70	100	70

How to adjust

- 1) Adjust the gain Pr11 and Pr12 which relate to the velocity loop.
- 2) Adjust the position loop gain, Pr10.
- 3) Pr10 (Position loop gain) should be smaller than Pr11 (Velocity loop gain).

<Note>

You cannot adjust the current loop gain, since these are fixed per the model.

How to Adjust the Gain at Position Control Mode

- 1) Start the motor (machine).
- 2) Set Pr10 (1st Position Loop Gain) to 50.
- 3) Increase the value of Pr11 (1st Velocity Loop Gain) gradually until the motor (machine) does not generate abnormal sound or vibration.
- 4) CIncrease the value of Pr10 (1st Position Loop Gain) gradually until the motor (machine) does not generate abnormal sound or vibration.
- 5) Decrease the value of Pr12 (1st Velocity Loop Integration Time Constant) according to the In-position time.
 - With a larger value, positional errors may not be converged.
- 6) If you want to improve the response further, adjust Pr15 (Velocity Feed Forward) within the extent that the motor (machine) does not generate abnormal sound or vibration.
 - With a larger value, overshoot and/or chattering of in-position signals may occur, which results in a longer in-position time. Note that this may be improved by adjusting the value of Pr16 (Feed Forward Filter).

How to Adjust the Gains for Velocity Control

- 1.If the controller does not have a position loop gain
Adjust Pr11 (1st Velocity Loop Gain) and Pr12 (1st Velocity Loop Integration Time Constant). Note that Pr15 (Velocity Feed Forward) is not effective.
- 1) Increase the value of Pr11 (1st Velocity Loop Gain) gradually until the motor (machine) does not generate abnormal sound or vibration.
- 2) Decrease the value of Pr12 (1st Velocity Loop Integration Time Constant) gradually until the overshoot/undershoot is reduced to an acceptable level.
2. If the controller has a position loop gain
 - 1) Set Pr58 (Acceleration Time Set-Up), Pr59 (Deceleration Time Set-Up) and Pr5A (S-Curve Accel/Decel Time Set-Up) to 0.
 - 2) Increase the value of Pr11 (1st Velocity Loop Gain) gradually until the motor (machine) does not generate abnormal sound or vibration.
 - 3) Decrease the value of Pr12 (1st Velocity Loop Integration Time Constant) gradually until the overshoot/undershoot is reduced to an acceptable level.
 - 4) Adjust the position loop gain on the controller.

<Notes>

Position loop gain changes when you change the value of Pr50 (Velocity Command Input Gain).

	Pr50 value	Relationship between command voltage and velocity	Position loop gain set in the controller
	Default = 500	6V at 3000r/min	Assuming this is 1
Examples	250	6V at 1500r/min	1/2
	750	6V at 4500r/min	1.5 times

Adjustment

How to improve the response further

You can manually adjust the 2nd gain.

With the 2nd gain adjustment, you can expect quicker response.

1st Gain		2nd Gain	
Pr10	1st Position Loop Gain	Pr18	2nd Position Loop Gain
Pr11	1st Velocity Loop Gain	Pr19	2nd Velocity Loop Gain
Pr12	1st Velocity Integration Time Constant	Pr1A	2nd Velocity Integration Time Constant
Pr13	1st Speed Detection Filter	Pr1B	2nd Speed Detection Filter
Pr14	1st Torque Filter Time Constant	Pr1C	2nd Torque Filter Time Constant

<Example>

When you want to reduce the noise produced during the stopping (servo-locking), you set the lower gain after the motor stops.

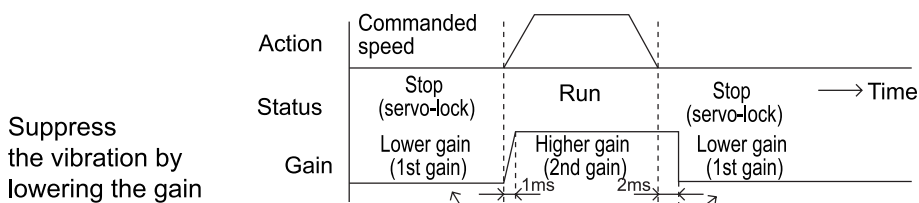

Parameters to be set-up		Setup value	Description
Pr30	2nd gain action set-Up	1	Switches to 2nd gains
Pr31	Position control switching mode	7	Switches to 2nd gains, if a position command is entered
Pr32	Position control switching delay time	12	Returns to 1st gains if "no command" status (no command pulse is entered for 166μs) lasts 2 ms.
Pr35	Position loop gain switching time	5	Shift from lower gain to higher gain at position control in a step of $((5+1) \times 166\mu s = 1ms)$. The set-up value should be smaller than the difference between Pr10 and Pr18.
Pr10	1st position loop gain	—	You can set the gains at the motor standstill.
Pr11	1st velocity loop gain		
Pr12	1st velocity integration time constant		
Pr13	1st speed detection filter		
Pr14	1st torque filter time constant		
Pr18	2nd position loop gain	—	You can set the gains during run.
Pr19	2nd velocity loop gain		
Pr1A	2nd velocity integration time constant		
Pr1B	2nd speed detection filter		
Pr1C	2nd torque filter time constant		

<Notes> For setting parameters for other control modes, see Appendix.

To reduce the mechanical resonance

If the machine is not stiff, vibration and noise may be generated due to the resonance by shaft torsion, and you may not be able to set-up the higher gains. You can suppress the resonance by 2 types of the filters.

1. Torque command filter (Pr14 and Pr1C)

Set the filter's time constant so that the frequency components around the resonance region can be attenuated.

You can obtain the cutoff frequency (fc) by the following formula;

$$\text{Cutoff frequency, } f_c \text{ (Hz)} = \frac{1}{(2\pi \times \text{Parameter value} \times 0.00001)}$$

2. Notch filter (Pr1D and Pr1E)

Adjust the notch frequency of the filter to the resonance frequency.

Pr1D	Notch frequency	Set this about 10% lower than the resonance frequency measured by the frequency characteristics analysis function of PANATERM.
Pr1E	Notch width selection	Use the default value of 2.

Resonance characteristics

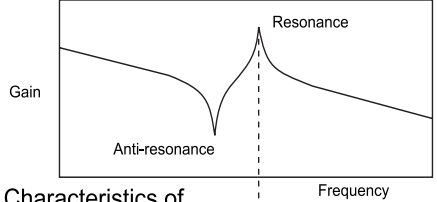

Characteristics of notch filter

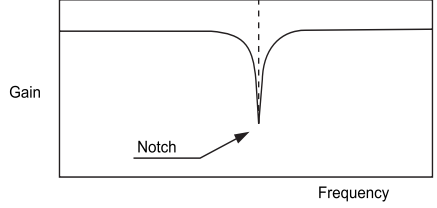

How to measure the resonance frequency of a machine system

- 1) Log-on PANATERM and open the frequency characteristics screen.
- 2) Set the following parameters and measuring conditions. Note that the values shown below are only guidance.
 - Decrease the value of Pr11 (1st Velocity Loop Gain) to 25 (to make the resonance frequency more distinguishable).
 - Set the amplitude to 50 r/min (so that the torque may not saturate).
 - Set the offset to 100 r/min. (to increase the amount of velocity detection information, and run the motor in one-way rotation).
 - Polarities: (+) for CCW and (-) for CW.
 - Set the sampling rate to 1 (from a range between 0 and 7).
- 3) Start the frequency characteristics analysis function.

<Notes>

- Before starting the measurement, make sure that the machine does not move beyond the limit.
Approximate speed = Offset (r/min.) x 0.017 x (Sampling rate + 1)
With a larger offset value, good results can be obtained, though the speed becomes higher.
- Set-up Pr22 (Real time auto tuning mode set-up) to 0.

<Notes>

- Set-up the offset larger than the amplitude setting, and with one-way rotation so that you can obtain better results.

Protective Functions

What are the Protective Functions?

The MINAS driver has various protective functions. When one of the protections is activated, the motor trips according to the timing chart shown in "Error Handling" in Appendix, and the Servo Alarm Output (ALM) is turned off.

Actions to be taken after trip events

- After a trip event, the LED touch panel displays an alarm code no., and no Servo-ON occurs.
- Any trip status is cleared by keeping A-CLR (Alarm Clear Input) on for at least 120 ms after A-CLR off.
- The overload protection can be cleared by A-CLR at least 10 seconds after the occurrence of the event. If the control power connection between r and t is opened, the time limiting operation is cleared.
- The alarms mentioned above can also be cleared with the LED touch panel. See Alarm Clear Modes in Appendix.
- The alarms mentioned above can also be cleared by using PANATERM.

<Notes>

Protections marked with * cannot be cleared with A-CLR (Alarm Clear Input). They should be cleared by turning the power off, removing the causes, and then turning the power on again.

Protective Functions: Causes and Corrections

Protection	Alarm Code No.	Cause	Countermeasures
Undervoltage, control power	11	The P-N voltage of the control power converter is lower than the specified value. Or the control voltage is too low due to an instantaneous outage or shortage of power capacity.	Measure the P-N voltage to check whether the voltage is correct or not. Modify the control voltage to an acceptable value, and/or increase the power capacity.
Overvoltage error	12	The line voltage is larger than the specified acceptable range, so that the P-N voltage of the converter is larger than the specified value, or the line voltage was raised by a condensive load or UPS (Uninterruptible Power Supply).	Measure the terminal-to-terminal voltages (between L1, L2 and L3). Remove the causes. Feed a power of correct voltage.

Protection	Alarm Code No.	Cause	Countermeasures
Overvoltage error (continued)	12	<ol style="list-style-type: none"> 1) The internal regenerative discharge resistor is disconnected. 2) The external regenerative discharge resistor is not suitable so that regenerative energy cannot be absorbed. 3) The driver (circuit) failed. 	<ol style="list-style-type: none"> 1) Measure the P-B1 resistance of the driver using a circuit tester. If it read ∞, the connection is broken. Replace the driver. Insert an external regenerative discharge resistor between the P and B2 terminals. 2) Use a resistor having the specified resistance for specified Watt. 3) Replace with a new driver (that is working correctly for another axis).
Undervoltage, main power	13	<ol style="list-style-type: none"> 1) The P-N voltage of the main power converter is lower than the specified value during Servo-ON. 2) The main power line voltage is too low, an instantaneous outage occurred, the power source is too small, the main power is turned off, or the main power is not fed. 3) Too small power source: the line voltage dropped due to the inrush current at power on. 	<p>Measure the terminal-to-terminal voltages (between L1, L2 and L3).</p> <ol style="list-style-type: none"> 1) Increase the capacity of the main power or replace it with a larger one. Or remove the causes of the failure of the magnetic contact, and then restart the power source. 2) Increase the capacity of the main power. For the required capacity, see "List of Applicable Components". 3) Correct the phase (L1, L2 and L3) connections of the main power. If the main power is single-phase 100V, use L1 and L3. 4) Check the timing of power-on (for both the main power and control power).

Important information

Protective Functions

Protection	Alarm Code No.	Cause	Countermeasures
*Overcurrent error	14	<p>The current flowing in the converter is larger than the specified value.</p> <ol style="list-style-type: none"> 1) The driver failed (due to defective circuits or IGBT parts). 2) Motor wires (U, V and W) are shorted. 3) Motor wires (U, V and W) are grounded. 4) Motor burned 5) Poor connection of Motor wires 6) The relay for the dynamic brake is melted and stuck due to the frequent Servo-ON/OFF. 7) The motor is not compatible with the driver. 	<ol style="list-style-type: none"> 1) Disconnect the motor wires, and enter Servo-ON. If this trouble happens immediately, replace the driver with a new one (that is working correctly). 2) Check if the U, V and W wires are shorted at the connections. Reconnect them, if necessary. 3) Measure the insulation resistance between U/V/W and earth wire. If the resistance is not correct, replace the motor with a new one. 4) Measure the resistance between U, V and W. If they are unbalanced, replace the motor with a new one. 5) Check if the U/V/W connector pins are firmly secured with screws. Loosened pins should be fixed firmly. 6) Replace the driver with a new one. Do not start or stop the motor by entering Servo-ON or OFF. 7) Check the capacity of the motor and driver on the nameplate. If the motor is not compatible with the driver, replace it with a correct one.
* Overheat error	15	<p>The radiator is heated up to exceed the limit temperature. The power elements of the driver is overheated. Overload.</p>	<p>Check the ambient temperature and cooling conditions. Check the load rate. Make the environment under which the driver operates. Reduce the load.</p>

Protection	Alarm Code No.	Cause	Countermeasures
Overload error	16	<p>Overload protection is activated via the specified time limiting operation when the integration of a torque command exceeds the specified overload level. Caused by a long operation with a torque that exceeds the specified torque limit.</p> <ol style="list-style-type: none"> 1) Long operation with more load and torque than the rating. 2) Vibration or hunting due to incorrect gains. Cause vibration and/or abnormal sound. 3) Motor wires connected wrong or broken 4) The machine is hit against a heavy hing, or suddenly becomes heavy in operation. The machine is en tangled. 5) The electromagnetic brake is ON. 6) In a system of multiple drivers, some motors are wired incorrectly to other axis. 	<p>Monitor the torque (current wave) using an oscilloscope to check whether the torque is surging or not. Check the load factor and overload alarm messages.</p> <ol style="list-style-type: none"> 1) Increase the capacity of the driver and motor. Lengthen the ramp time of acceleration/deceleration. Reduce the motor load. 2) Readjust the gains. 3) Correct the motor wiring per the wiring diagrams. Replace cables. 4) Free the machine of any tangle . Reduce the motor load. 5) Measure the voltage at the brake wiring connections. Turn off the brake. 6) Correct the motor and encoder wiring to eliminate the mismatching between the mo
Regenerative discharge	18	<p>The regenerative energy is larger than the capacity of the regenerative discharge resistor.</p> <ol style="list-style-type: none"> 1) When the load inertia is too large,the converter voltage increases due to the large energy regener ated during deceleration, and in creases more due to the shortage of energy consumption by the regenerative discharge resistor. 2) When the velocity of the motor is too high, the regenerative energy cannot be consumed within the 	<p>Check the load rate of the regenerative resistor in the Monitor mode. The driver should not be used with continuous regenerative braking.</p> <ol style="list-style-type: none"> 1) Check the operation pattern (using the velocity monitor). Check the load rate of the regenerative resistor and the over-regeneration alarm on display. Increase the capacity of the driver and motor. Increase the deceleration time. Use an external regenerative resistor. Check the connection wire between B1 and B2 terminals. 2) Check the operation pattern (using the velocity monitor). Check the load rate of the regenerative resistor and

Protective Functions

Protection	Alarm Code No.	Cause	Countermeasures
* Encoder A/B-phase error	20	No A- and B-phase pulse is detected. The 11-wire encoder failed.	Correct the encoder wiring per the wiring diagram. Correct the connection of the pins.
* Encoder communication error	21	Due to no communication between the encoder and driver, the detective function for broken encoder wires is activated.	
* Encoder connection error	22	The connection between the 11-wire encoder and driver is broken. The encoder rotates higher than the specified rate when control power is on.	Make sure that the power of the encoder is 5VDC \pm 5% (4.75 to 5.25V). Especially when the wire length is long, it is important to meet this requirement. You should not bundle the encoder wires and motor wires together. Connect the shield to FG. See the encoder wiring diagram.
* Encoder communication data error	23	The encoder sends an erroneous data mainly due to noises. The encoder is connected correctly, though the data is not correct.	
Position error	24	The position error pulse is larger than Pr63 (position error limit). The motor operation does not respond to the commands.	Check whether the motor operates per the position command pulse or not. See the torque monitor to check if the output torque is saturated. Readjust the gains. Maximize the value of Pr5E (torque limit set-up). Correct the encoder wiring per the wiring diagram. Increase the acceleration and deceleration time. Reduce the load and velocity.
Hybrid error	25	When the driver of the full-closed version is under the full-closed and hybrid control with an external encoder, the load position detected by the external encoder and the motor position detected by the motor encoder are beyond the limit specified by Pr73 (hybrid error limit).	Check the connection between the motor and load. Check the connection between the external encoder and driver. Correct the values of the external scale numerator and denominator regarding parameters Pr74, Pr75, Pr 76 and Pr77. Increase the value of Pr73. Increase the value of Pr71 (hybrid switching time).
Over-speed	26	The motor velocity exceeds the specified limit.	Decrease the target speed (command values). Decrease the value of Pr50 (velocity command input gain). Adjust the scale ratio so that the frequency of the command pulse is 500 kpps or less. If an overshoot occurs, readjust the gains. Correct the encoder wiring per the wiring diagram. AB

Protection	Alarm Code No.	Cause	Countermeasures
Command pulse sealer error	27	The command pulse is larger than 500 kpps at the entrance of the position error counter. The scale ratios set by Pr46 through Pr4B (numerator of 1st to 4th command scale) are not correct.	Reduce the multiplication factor by adjusting the values of Pr46 through Pr4B, and then adjust the scale ratios so that the command pulse frequency is 500 kpps or less.
External scale error	28	When Pr76 (scale error invalidation) = 0, and the driver is operated under the full-closed and hybrid control with an external encoder, the scale error input is OFF.	Check the reason why the CN I/F Pin 33 is OFF.
Error counter over flow	29	The value of the position error counter is over 227 (134217728).	Check that the motor operates per the position command pulse. See the torque monitor to check that the output torque does not get saturated. Readjust the gains. Maximize the value of Pr5E (torque limit set-up). Correct the encoder wiring per the wiring diagram.
* External scale disconnection error	35	The external scale is disconnected, or the scale fails.	Check the power supply for the external scale. Correct the wiring and SIG connections per the wiring diagram.
* EEPROM parameter error	36	The data contained in the parameter storage area of the EEPROM is broken, so erroneous data is retrieved.	Set all the parameters again. If this error occurs frequently, the driver may have been broken. Replace the driver with a new one. Return the old driver to the sales agent for repair.
* EEPROM check code error	37	The check code of the EEPROM is broken, so erroneous data is retrieved.	The driver may have been broken. Replace the driver with a new one. Return the old driver to the sales agent for repair.
Overtravel inhibit	38	Both the CW and CCW over-travel limits are not active.	Check the switches, wires and power supply that constitute the circuits. Check that the control power (12 to 24VDC) can be established without delay. Check the value of Pr04. Correct the wiring, if necessary.

Protective Functions

Protection	Alarm Code No.	Cause	Countermeasures
Absolute system down error	40	The power of the encoder is out.	Check the voltage of the battery. Connect to the battery, and then clear the encoder using the absolute encoder clear mode contained in the auxiliary function (see Details of Operation in Appendix).
Absolute encoder counter overflow	41	The data of the multi-turn counter of the encoder exceeds the specified limit.	Limit the movable range to 32767 revolutions (15 bits) from the initial position. Adjust the value of Pr0B.
Absolute encoder overspeed error	42	The encoder rotates faster than the specified rate when it is battery-powered.	Connect the power to the encoder and then make sure that the encoder voltage is 5V±5%. Correct the SIG connections, if necessary.
* Absolute encoder single-turn counter error	44	The encoder detects an error of the single-turn counter.	The motor may be broken. Replace the motor with a new one. Return the old motor to the sales agent for repair.
* Absolute encoder multi-turn counter error	45	The encoder detects an error of the multi-turn counter.	
Absolute encoder status error	47	The encoder detects an internal status error. After the control power on, the encoder rotates faster than the specified rate.	Take measures to keep the motor away from rotating until the driver outputs S-RDY. Take measures to keep the motor away from rotating until the driver outputs S-RDY.
Full close selection error	97	When an 11-wire encoder is used, Pr02 (control mode selection) is set to 7, 8 or 9 ("full-close" control).	Set the value of Pr02 to 0, 1, 2, 3, 4 or 5.
* Other error error	E E E E E 3 3 3 3 3 F F F F F 7 7 7 7 7	The control circuit operates incorrectly due to large noises or any other reasons.	Turn off the power and turn it on again. If the error cannot be eliminated, the motor and/or driver may be broken. Disconnect the power supply of these equipment, and replace them with new ones. Return the old equipment to the sales agent for repair.
* Other error	Numbers other than the above	The driver's self-diagnosing function is activated, because an error happens in the driver.	

Maintenance and Inspections

- Routine maintenance and inspections are essential for proper and satisfactory operation of the driver and motor.

Notes to Maintenance/Inspections Personnel

- 1) Power-on/off operations should be done by the operators themselves.
- 2) For a while after power off, the internal circuits is kept charged at higher voltage. Inspections should be done a while (about 10 minutes), after the power is turned off and the LED lamp on the panel is extinguished.
- 3) Do not take insulation resistance measures because the driver gets damaged.

Inspection Items and cycles

Normal (correct) operating conditions:

Ambient temperature: 30°C (annual average) Load factor : max. 80%
 Operating hours : max. 20 hours per day

Daily and periodical inspections should be done per the following instructions.

Type	Cycles	nspection items
Daily inspection	Daily	<ul style="list-style-type: none"> • Ambient temperature, humidity, dust, particles, foreign matters, etc. • Abnormal sound and vibration • Main circuit voltage • Odor • Lint or other foreign matters in the ventilation openings • Cleanliness of the operation board • Damaged circuits • Loosened connections and improper pin positions • Foreign matters caught in the machine (motor load)
Periodical inspection	Every year	<ul style="list-style-type: none"> • Loosened screws • Signs of overheat • Burned terminals

Important information

<Notes>

If the actual operating conditions differ from things mentioned above, the inspection cycles may change accordingly.

Maintenance and Inspections

Replacement Guidance

Parts replacement cycles depend on the actual operating conditions and how the equipment has been used. Defective parts should be replaced or repaired immediately.

 Prohibited	Dismantling for inspections or repairs should be done by our company (or our sales agents).
---	---

Equipment	Part	Standard replacement cycles (hour)	Remarks
Driver	Smoothing condenser	about 5 years	The replacement cycles shown here are just only for reference. If any part is found defective regardless of the standard replacement cycles, immediately replace it with a new one.
	Cooling fan	2 to 3 years (10 to 30 thousand hours)	
	Aluminum electrolytic capacitor on the print board	about 5 years	
Motor	Bearing	3 to 5 years (20 to 30 thousand hours)	
	Oil seal	5000 hours	
	Encoder	3 to 5 years (20 to 30 thousand hours)	
	Battery (Absolute encoder)	1 year from the first use	

Troubleshooting

The motor does not rotate.

[Check Points]

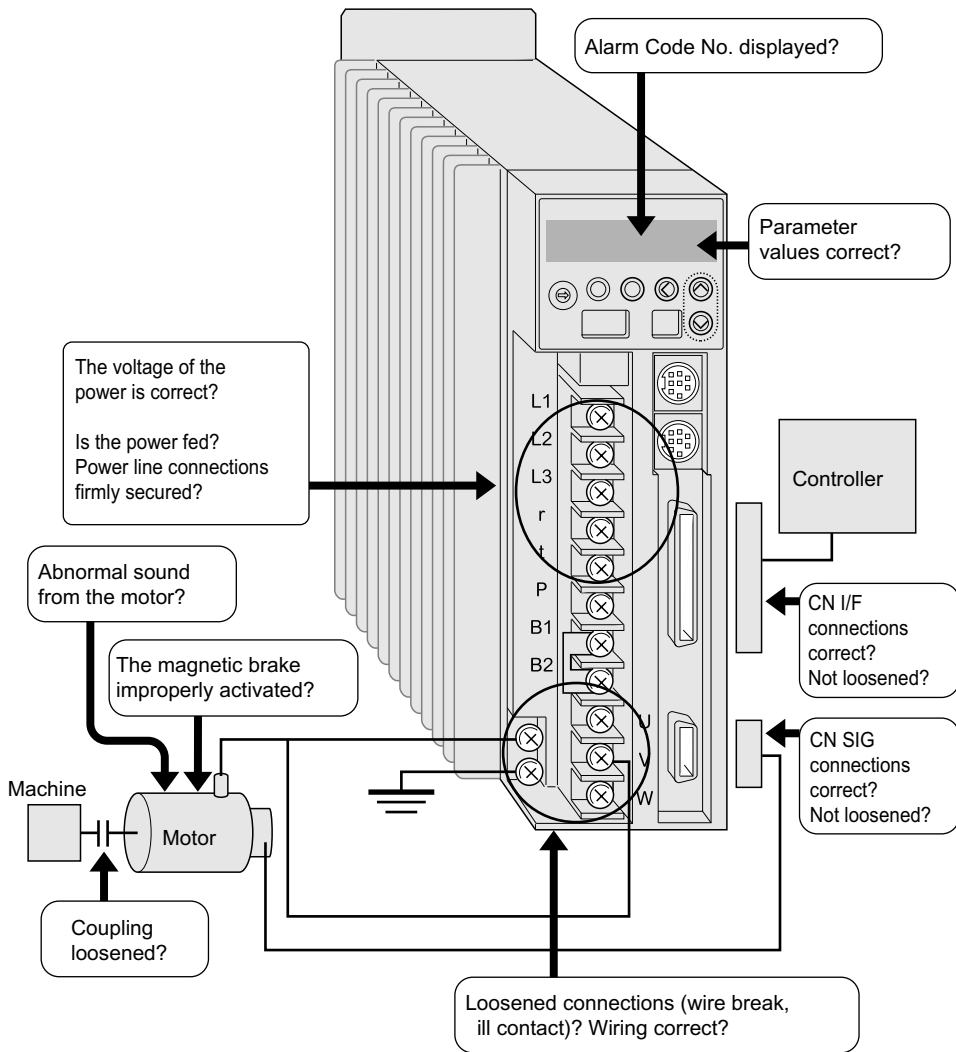

Important Information

Troubleshooting

The motor does not rotate.

Category	Causes	Countermeasures
Parameters	The control mode selected is not correct.	Check the value of Pr02 (control mode set-up). 0: position control, 1: velocity control, 2: torque control
	The internal velocity command (switching between internal and external commands) does not work.	Check the value of Pr05 (Internal speed switching). 0: At analogue velocity command set-up, Change the value to 1 or 2.
	The torque limit inhibition setting is not correct.	Check the value of Pr03 (Analog torque limit inhibit). 0: torque cannot be produced, so the motor does not rotate. Change the value to 1.
	The torque limit has been set to 0.	Check the value of Pr5E (torque limit set-up).
	The zero speed clamp is ON, so the motor does not operate.	Change the value to 300 (default). Check the value of Pr06 (ZERPSPD input selection).
Wiring	The circuit for CW/CCW overt-ravel inhibit is open.	Change the value to 0. If the value is 1, the zero clamp function is valid. If you desire to set the parameter to 1, enable the zero speed clamp input, and adjust the wiring so that the zero speed clamp input can be turned on correctly. Check the value of Pr04. If the value is 0, connect between CN I/F pins 9 and 41, and 8 and 41.
	CN I/F Servo-ON signal is not received.	Connect (short circuit) between CN I/F pins 29 and 41.
	CN I/F Counter clear is ON (shorted).	Disconnect between CN I/F pins 30 and 41.
	CN I/F command pulse input inhibit is active, so the motor does not operate.	Check the value of Pr43. If the value is 0, connect between CN I/F pins 33 and 41. If the value is 1, the command pulse input inhibition is disregarded, so the motor will rotate according to command pulses.
Installation	Bearing lock	Turn off the power. Disconnect the motor. Rotate the motor shaft by hand to make sure that the motor rotates freely. If the motor is fitted with an electromagnetic brake, rotate the shaft by hand while applying a voltage (24VDC) to the brake. If the motor does not rotate, consult the sales agent to repair it.

The rotation is not smooth.

The motor rotates slowly even if the target speed is zero in the speed control mode.

Category	Causes	Countermeasures
Parameters	The control mode selection is not correct.	With the position control mode selected, if Pr02 is set to other than 0, the motor will rotate slowly because Pr52 (velocity command offset) governs the operation of the motor. Change the value of Pr02 to 0.
Adjustment	The gains are not appropriate.	Increase the value of Pr11 (1st velocity loop gain). Insert a torque filter (Pr14) and then further increase the value of Pr11.
	Velocity and position commands are not stable.	Check the behavior of the motor using the check pin on the LED touch panel and the wave form graphics function of PANATERM. Check the wiring and its connections. Check the controller.
Wiring	<p>CN I/F signals are chattering.</p> <p>1) Servo-ON signal</p> <p>2) CW/CCW torque limit input signal</p> <p>3) Counter clear input signal</p> <p>4) Speed zero clamp signal</p> <p>5) Command pulse input inhibit signal</p>	<p>1) Check the wiring and connections between CN I/F pins 29 and 41 by monitoring the display of input and output signals status. Modify the wiring so that Servo-ON signals can be made active correctly. Check the controller.</p> <p>2) Check the wiring and connections between CN I/F pins 17 and 18, and 16 and 17 using a circuit tester and/or oscilloscope. Modify the wiring so that CW/CCW torque limit input can be made active correctly. Check the controller.</p> <p>3) Check the wiring and connections between CN I/F pins 30 and 41 by monitoring the display of input and output signals status. Modify the wiring so that Position Error Counter input can be made active correctly. Check the controller.</p> <p>4) Check the wiring and connections between CN I/F pins 26 and 41 by monitoring the display of input and output signals status. Modify the wiring so that Zero Speed Clamp input can be made active correctly. Check the controller.</p> <p>5) Check the wiring and connections between CN I/F pins 33 and 41 by monitoring the display of input and output signals status. Modify the wiring so that Command Pulse Input Inhibit can be made active correctly. Check the controller.</p>

Troubleshooting

Category	Causes	Countermeasures
Wiring	Velocity commands contain noises.	Use shielded cables for connection to CN I/F. Power and signal cables should be separated by at least 30 cm and put in duct.
	Improper offset	
	Velocity commands contain noises.	Measure the voltage between CN I/F pins 14 and 15 (velocity command inputs) using a circuit tester and/or oscilloscope. Adjust the value of Pr52 so that the motor can stop.
		Use shielded cables for connection to CN I/F. Power and signal cables should be separated by at least 30 cm and put in duct.

Positioning accuracy is bad.

Category	Causes	Countermeasures
System	Position commands (amount of command pulses) are not correct.	Count the number of feedback pulses while repeating to travel back and forth within a fixed distance. If the number of feedback pulses varies, adjust the controller. Take measures to reduce the noise on the command pulse.
	Reading of in-position signals occurs at the edge.	Use the check pin (IM), to monitor the position error when the in-position signals are received. Read the in-position signals at a mid point on the time span, not at the edge. If the command pulses are deformed or narrowed, adjust the pulse generation circuit. Take measures to reduce the noise on the command pulse.
	The form and width of the command pulses deviate from the specified values.	
Adjustment	The position loop gain is too small.	Check the amount of position error in the monitor mode. Increase the value of Pr10 to the extent that no oscillation occurs.
Parameter	The setting of in-position detection range (Pr60) is too large.	Decrease the value of Pr60 (in-position range) to the extent that the in-position signals do not chatter.
	The command pulse frequency exceeds 500 kpps.	Decrease the command pulse frequency. Change the values of Pr46 through Pr4B (numerator of 1st to 4th command scale).
	The scale is not appropriate.	Check the repetition accuracy. If repeated without fluctuation, increase the capacity of the motor and driver.

Category	Causes	Countermeasures
Wiring	CN I/F signals are chattering: 1) Servo-ON signals 2) Counter clear input signal 3) CW/CCW torque limit input signal 4) Command pulse input inhibit signal	1) Check the wiring and connections between CN I/F pins 29 and 41 by monitoring the display of input and output signals status. Modify the wiring so that Servo-ON signals can be made active correctly. Check the controller. 2) Check the wiring and connections between CN I/F pins 30 and 41 by monitoring the display of input and output signals status. Modify the wiring so that Position Error Counter input can be made active correctly. Check the controller. 3) Check the wiring and connections between CN I/F pins 17 and 18, and 16 and 17 using a circuit tester and/or oscilloscope. Modify the wiring so that CW/CCW torque limit input can be made active correctly. Check the controller. 4) Check the wiring and connections between CN I/F pins 33 and 41 by monitoring the display of input and output signals status. Modify the wiring so that Command Pulse Input Inhibit can be made active correctly. Check the controller.
Installation	Load inertia is large.	Check the overshoot at stop using the wave form graphics function of PANATERM. Adjust the gains. If this is not effective, increase the capacity of the driver and motor.

The initial (home) position varies.

Category	Causes	Countermeasures
System	When calculating the initial (home) position, the Z-phase output is not detected.	Check that the Z-phase accords to the center of the proximity dog. Perform initialization correctly according to the controller.
	Creep speed to initial position is too high.	Decrease the return speed near the initial (home) position, or lengthen the initialization sensor.
Wiring	The output of the initial (home) position proximity sensor (dog sensor) is chattering.	Check the input to the sensor using an oscilloscope. Modify the wiring around the sensor. Take measures to reduce the noise.
	Noise on encoder wires	Take measures to reduce the noise (noise filters, ferrite cores, etc.). Properly connect the shield wires of I/F cables. Use twist-paired wires. Separate the signal and power wires.

Troubleshooting

Category	Causes	Countermeasures
Wiring	Z-phase signal is not output.	Monitor the Z-phase signal using an oscilloscope. Check that CN I/F Pin 13 is connected to the ground terminal of the controller. Connect the open collector to the ground of the driver. Replace the driver and controller, or repair them. Check that the line driver is connected at the both sides. If
	The circuit for Z-phase signal is not correct.	the controller does not have a differential input, use CZ output (open collector).

The motor produces an abnormal sound and/or vibration.

Category	Causes	Countermeasures
Wiring	Velocity commands contain noises.	Check the wiring between CN I/F Pins 14 and 15 (velocity command inputs) using an oscilloscope. Take measures to reduce the noise (noise filters, ferrite cores, etc.). Properly connect the shield wires of I/F cables. Use twist-paired wires. Separate the signal and power wires.
Adjustment	The gains are too large.	Decrease the values of Pr10 (velocity loop gain) and Pr11 (position loop gain).
	The velocity detection filter is not correct.	Increase the value of Pr13 (speed detection filter) until the sound decreases to an acceptable level, or return the value to 4 (default).
Installation	Resonance between the machine and motor occurs.	Adjust the value of Pr14 (torque filter). Check the mechanical resonance using the frequency characteristics analysis program in PANATERM. If a resonance occurs, set Pr10(notch frequency).
	Motor bearing	Operate the motor without load in order to check the sound and vibration near the bearing. Replace the motor and operate it to do the same checks. Repair the motor, if necessary. Operate the motor without load or use a new motor in order
	Electromagnetic sound, gear sound, braking sound, hub sound, rubbing sound from the encoder, etc.	to locate the source of sounds. Repair the motor, if necessary.

Overshoot or undershoot

The motor overheats (burnt)

Category	Causes	Countermeasures
Adjustment	Gains are not correct.	Check the gains using the wave form graphics monitoring function of PANATERM, speed monitor (SP) and/or torque monitor (IM). Adjust the gains. See "Adjustments" chapter.
Installation	Load inertia is too large.	Check the load inertia using the wave form graphics monitoring function of PANATERM, velocity monitor Check the coupling between the motor and machine.
	Rattling or slip of the machine	If the ambient temperature is higher than the specified value, install a cooling fan.
	Environment (ambient temperature, etc.)	Check the cooling fans of the driver and machine. The cooling fan of the driver should be replaced at regular cycles.
	The cooling fan does not work. The air intake is dirty.	This replacement should be done by a service engineer of the sales agent.
	Mismatch between the driver and motor	Check the nameplates of the driver and motor. For available combinations between driver and motor, see the instruction manuals or catalogues.
	Motor bearings fail.	Turn off the power. Rotate the motor shaft by hand to check whether abnormal sound (rumbling) occurs or not. If it rumbles, replace it with a new one, or repair it.
	The electromagnetic brake is ON (failure to release the brake).	Check the voltage at the brake terminal. Apply 24VDC to release the brake.
	The motor fails (due to oil, water, etc.). The motor is operated by external	Avoid high temperature/humidity, oil, dust and iron powders.
	forces while the dynamic brake is activated.	Check the operation pattern, use and working status. This kind of operation should be avoided.

Troubleshooting

The motor speed does not increase up to the specified value.

The speed (movement) is too large or small.

Category	Causes	Countermeasures
Parameter	The velocity command input gain is not correct.	Check that the value of Pr50 (velocity command input gain) is 500 (i.e. 3000rpm/6V).
Adjustment	The position loop gain is too small. The scale is not appropriate.	Adjust the value of Pr10 (position loop gain) to approximately 100.
		Correct the values of Pr46 (numerator of 1st command pulse ratio), Pr4A (Multiplier of numerator of command pulse ratio) and Pr4B (denominator of pulse command scale). See "Details of Parameters" chapter.

Parameter values change to the former value.

Category	Causes	Countermeasures
Parameter	Parameter values are not downloaded into EEPROM before power off.	See "Parameter Setting" chapter (page 52).

In PANATERM, a message "communication port or driver cannot be detected" appears.

Category	Causes	Countermeasures
Wiring	The communication cable (RS232C) is connected to CN NET.	The communication cable (RS232C) must be connected to CN SER.

Appendixes

Conform to EC Directives and UL Standards	App. 2
List of Connectable Motors	App. 7
How to Use	
• Holding brake	App. 9
• Dynamic brake	App. 12
• Timing chart	App. 14
• Allowable loads on output axes	App. 18
• Initialization (Precautions)	App. 19
"Absolute" Driver	App. 20
Full Close" Driver	App. 28
Details of Parameters	App. 30
Details of Operation	App. 57
Overview of a Communication Control Software PANATERM	App. 67
Optional Parts (encoder cables, motor cables, brake cable connector kits, communication cables, communication control software PANATERM, mounting brackets and reactors)	App. 69
Recommended Parts	
• Surge absorber for motor brake	App. 84
• List of peripheral equipment manufacturers	App. 85
Outer Views and Dimensions	
• Motor	App. 86
• Driver	App. 100
Properties	
Overload protection: time-related characteristics	App. 106
Specifications	
• Gain switching conditions for each control mode	App. 107
• Block diagrams	App. 109
• Specifications of driver	App. 113

Conformance to EC Directives and UL Standards

EC Directives

The EC Directives apply to all such electronic products as those having specific functions and directly sold to general consumers in EU countries. These products are required to meet the EU unified standards and to be furnished with CE Marking.

Our product, AC servo, has specific functions, but is not sold directly to general consumers, i.e. this product is regarded as a component that constitutes a machine or equipment. Therefore, the product (AC servo) is not required to be furnished with CE Marking.

However, our AC servos meet the EC Directives for Low Voltage Equipment so that the machine or equipment comprising our AC servos can meet relevant EC Directives.

EMC Directives

Our servo systems can meet EMC Directives and related standards. However, to meet these requirements, the systems must be limited with respect to configuration and other aspects, e.g. the distance between the servo driver and motor is restricted, and some special wiring conditions must be met. This means that in some cases machines and equipment comprising our servo systems may not satisfy the requirements for wiring and grounding conditions specified by the EMC Directives. Therefore, conformance to the EMC Directives (especially the requirements for emission noise and noise terminal voltage) should be examined based on the final products that include our servo drivers and servo motors.

Applicable Standards

Subject	Applicable standard	
Motor	IEC34-1	Standards referenced by Low-Voltage Directive
Motor and driver	EN50178	
	IEC61800-3	EMC Requirements for Variable Speed Electric Power Driven Systems
	EM55011	Radio Disturbance Characteristics of Industrial, Scientific and Medical (ISM) Radio-Frequency Equipment
	IEC61000-4-2	Electrostatic Discharge Immunity Test
	IEC61000-4-3	Radio Frequency Electromagnetic Field Immunity Test
	IEC61000-4-4	Electric High-Speed Transition Phenomenon - Burst Immunity Test
	IEC61000-4-5	Lightning Surge Immunity Test
	IEC61000-4-6	High Frequency Conduction - Immunity Test
IEC61000-4-11	Instantaneous Outage- Immunity Test	
		Standards referenced by EMC Directives

IEC: International Electrical Commission

EN Europäischen Normen

EMC: Electromagnetic Compatibility

Peripheral Equipment

Environment

The servo driver should be used under Contamination Level 2 or 1 specified by IEC60664-1 (housing the driver in an IP54 control box).

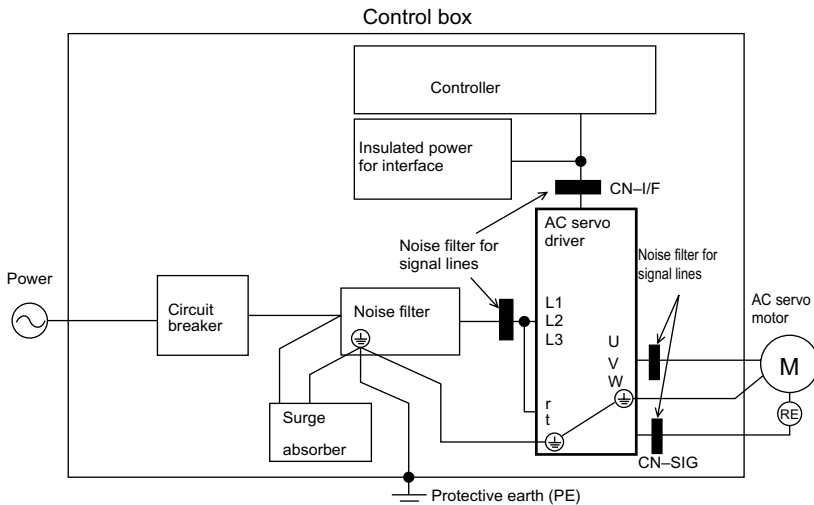

Power

100V system: Single-phase 100 to 115V +10%/-15%, 50/60Hz

200V system: Three-phase 200 to 230V +10%/-15%, 50/60Hz

(1) Use under the environment of Over-voltage Category III specified by IEC60664-1.

(2) The power for interface should be marked CE or EN Standard (EN60950) type, 12VDC to 24VDC, insulated.

Circuit Breaker

Install a circuit breaker between the power supply and noise filter. The circuit breaker should be IEC Standard and UL listed (UL marked).

Noise Filter

If several drivers are used, and a single noise filter is installed at the power supply, consult the manufacturer of the noise filter.

Surge Absorber

Install a surge absorber at the primary side of the noise filter.

<Notes>

When performing a voltage-resisting test, remove the surge absorber. Otherwise the absorber may be damaged.

Noise Filters for Signal Lines

Install noise filters.

Install noise filters (specially designed for signal wires) for all cables (power, motor, encoder and interface wires).

Grounding

- 1) Connect between the servo driver's protective earth terminal (⊕) and control box's protective earth (PE) to prevent electric shocks.
- 2) Multiple connections to a single protective earth terminal (⊕) should be avoided. There are two protective earth terminals.

Peripheral Devices Applicable to Drivers (EC Directives)

Driver's Series No.	Voltage	Output rating	Circuit breaker (current rating)	Noise filter	Surge absorber	Noise filter for signal lines
MSDA MQDA	100V	30W ~ 200W	10 A	DVOP1441	DVOP1450	DVOP1460
		400W	15 A	DVOP1442		
MSDA MQDA	200V	30W ~ 400W	10 A	DVOP1441		
MGDA		300W	15 A	DVOP1442		
MSDA		750W, 1kW				
MDDA		750W, 1kW				
MFDA		400W, 750W				
MHDA		500W, 1kW				
MGDA		600W, 900W				
MSDA		1.5kW				
MDDA		1.5kW				
MFDA		1.5kW	20 A			
MHDA		1.5kW	30 A			
MGDA		1.2kW				
MSDA		2kW, 2.5kW				
MDDA		2kW, 2.5kW				
MFDA		2.5kW				
MHDA		2kW				
MGDA		2kW				
MSDA		3kW ~ 5kW	50 A	DVOP1443		
MDDA		3kW ~ 5kW				
MHDA	3kW ~ 5kW					
MFDA	3.5kW, 4.5kW					
MGDA	3kW, 4.5kW					

Surge Absorber

Optional Part No.	Manufacturer's Product No.	Manufacturer
DVOP1450	R•A•V-781BXZ-4	Okaya Electric Industries Co., Ltd.

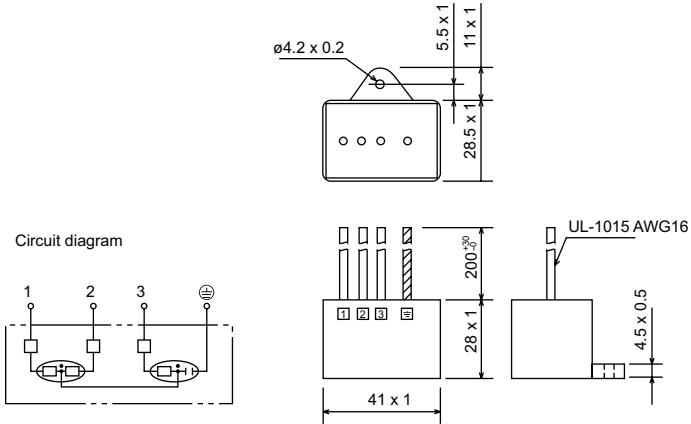

Install noise filters

Optional Part No.	Manufacturer's Product No.	Manufacturer
DVOP1460	ZCAT3035-1330	TDK Corporation

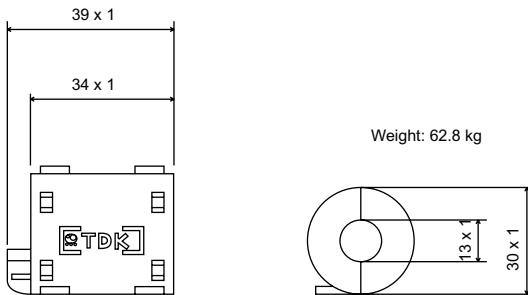

Noise Filters for Signal Lines

Noise Filter

Optional Part No.	Manufacturer's Product No.	Manufacturer
DVOP1441	3SUP-A10H-ER-4	Okaya Electric Industries Co., Ltd.
DVOP1442	3SUP-A30H-ER-4	
DVOP1443	SSUP-A50H-ER-4	

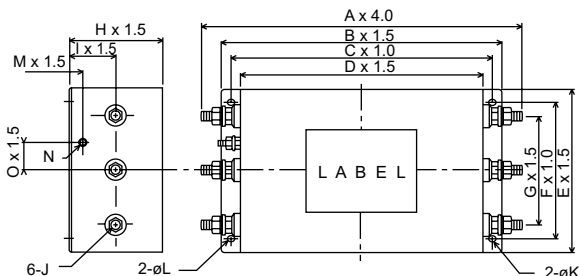

Circuit diagram

1
2
3

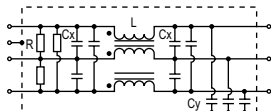

4
5
6

	A	B	C	D	E	F	G	H	I	J	K	L	M	N	O
DVOP1443	188	160	145	130	110	95	70	55	25	M5	4.5	ø4.5a7	10	M4	17.5
DVOP1442	228	200	185	170	110	95	70	60	30	M6	4.5	ø4.5a7	10	M4	17.5
DVOP1441	272	240	220	200	140	110	70	80	40	M6	6.5	ø6.5a8	15	M4	20

Conform to UL Standards

The noise filters conform to UL508C (File No. E164620) to satisfy the following conditions.

- 1) The servo driver should be used under Contamination Level 2 or 1 specified by IEC60664-1 (housing the driver in an IP54 control box).
- 2) Install a circuit breaker or fuse between the power supply and noise filter. The circuit breaker or fuse should be a UL listed (UL marked) type. The current rating of the circuit breaker or fuse should be per the table in page 4.

List of Motors applicable to Drivers

Driver with a 2500 P/r incremental encoder

Drivers	Size	Applicable motors								
		Series	Product name	Voltage	Output rating	Velocity rating	Encoder			
MDDA083AIA	Size 4-2	MDMA	MDMA082A**	200 V	750 W	2000r/min	Incremental, 2500 P/r, 11-wire			
MDDA103AIA			MDMA102A**		1.0kW					
MDDA153AIA			MDMA152A**		1.5kW					
MDDA203AIA	Middle Inertia	MDMA202A**	2.0kW							
MDDA253AIA		MDMA252A**	2.5kW							
MDDA303AIA		MDMA302A**	3.0kW							
MDDA353AIA	Size 5	Middle Inertia	MDMA352A**		3.5kW					
MDDA403AIA			MDMA402A**		4.0kW					
MDDA453AIA			MDMA452A**		4.5kW					
MDDA503AIA			MDMA502A**		5.0kW					
MHDA053AIA	Size 4-2	MHMA	MHMA052A**	200 V	500 W	2000r/min	Incremental, 2500 P/r, 11-wire			
MHDA103AIA			MHMA102A**		1.0kW					
MHDA153AIA			MHMA152A*		1.5kW					
MHDA203AIA	Size 43	High Inertia	MHMA202A**ñ		2.0kW					
MHDA303AIA			MHMA302A**		3.0kW					
MHDA403AIA	Size 5	High Inertia	MHMA402A**		4.0kW					
MHDA503AIA			MHMA502A**		5.0kW					
MFDA043AIA	Size 3	MFMA	MFMA042A**		200 V			400 W	2000r/min	Incremental, 2500 P/r, 11-wire
MFDA083AIA	Size 4-2		MFMA082A**					750 W		
MFDA153AIA			MFMA152A**					1.5kW		
MFDA253AIA	Size 43	Flat	MFMA252A**	2.5kW						
MFDA353AIA	Size 5		MFMA352A**	3.5kW						
MFDA453AIA			MFMA452A**	4.5kW						
MGDA033AIA	Size 3	MGMA	MGMA032A**	200 V		300 W	1000r/min	Incremental, 2500 P/r, 11-wire		
MGDA063AIA	Size 4-2		MGMA062A**			600 W				
MGDA093AIA			MGMA092A**			900 W				
MGDA123AIA			Size 43			MGMA122A**				
MGDA203AIA	Size 5				MGMA202A**	2.0kW				
MGDA303AIA			MGMA302A**		3.0kW					
MGDA453AIA			MGMA452A**		4.5kW					
MQDA011AIA			Size 1		MQMA	MQMA011A**			100 V	100 W
MQDA021AIA	Size 2	MQMA021A**	200 W							
MQDA041AIA	Size 3	MQMA041A**	400 W							
MQDA013AIA	Size 1	Flat Small	MQMA012A**	100 W						
MQDA023AIA			200 V	MQMA022A**		200 W				
MQDA043AIA				MQMA042A**		400 W				

List of Motors applicable to Drivers

Driver with a 17 bits absolute/incremental encoder

Drivers	Size	Applicable motors								
			Product name	Voltage	Output rating	Velocity rating	Encoder			
MDDA083DIA	Size 4-2	MDMA	MDMA082D**	200V	750W	2000r/min	Absolute/ Incremental, 17 bits, 7-wire, see Note 1)			
MDDA103DIA			MDMA102D**		1.0kW					
MDDA153DIA			MDMA152D**		1.5kW					
MDDA203DIA	Size 4-3	Middle Inertia	MDMA202D**		2.0kW					
MDDA253DIA			MDMA252D**		2.5kW					
MDDA303DIA	Size 5	Middle Inertia	MDMA302D**		3.0kW					
MDDA353DIA			MDMA352D**		3.5kW					
MDDA403DIA			MDMA402D**		4.0kW					
MDDA453DIA			MDMA452D**		4.5kW					
MDDM503DIA			MDMA502D**	5.0kW						
MHDA053DIA	Size 4-2	MHMA	MHMA052D**	200V	500W	2000r/min	Absolute/ Incremental, 17 bits, 7-wire, see Note 1)			
MHDA103DIA			MHMA102D**		1.0kW					
MHDA153DIA			MHMA152D**		1.5kW					
MHDA203DIA	Size 4-3	High Inertia	MHMA202D**		2.0kW					
MHDA303DIA			MHMA302D**		3.0kW					
MHDA403DIA	Size 5	High Inertia	MHMA402D**		4.0kW					
MHDA503DIA			MHMA502D**		5.0kW					
MFDA043DIA	Size 3	MFMA	MFMA042D**		200V			400W	2000r/min	Absolute/ Incremental, 17 bits, 7-wire, see Note 1)
MFDA083DIA	Size 4-2		MFMA082D**					750W		
MFDA153DIA			MFMA152D**	1.5kW						
MFDA253DIA	Size 4-3		Flat	MFMA252D**		2.5kW				
MFDA353DIA	Size 5			MFMA352D**		3.5kW				
MFDA453DIA				MFMA452D**		4.5kW				
MGDA033DIA	Size 3	MGMA	MGMA032D**	200V	300W	1000r/min	Absolute/ Incremental, 17 bits, 7-wire, see Note 1)			
MGDA063DIA	Size 4-2		MGMA063D**		600W					
MGDA093DIA			MGMA093D**		900W					
MGDA123DIA			Size 4-3		MGMA123D**			1.2kW		
MGDA203DIA	Size 5				MGMA203D**			2.0kW		
MGDA303DIA			MGMA303D**		3.0kW					
MGDA453DIA			MGMA453D**		4.5kW					
MQDA011DIA	Size 1		MQMA		MQMA011C**			100V	100W	3000r/min
MQDA021DIA	Size 2	MQMA021C**		200W						
MQDA041DIA	Size 3	MQMA041C**		400W						
MQDA013DIA	Size 1	Flat Small		MQMA012C**	100W					
MQDA023DIA				200V	MQMA022C**	200W				
MQDA043DIA					MQMA042C**	400W				

Holding brake

The brake is to hold the work (movable part coupled to a vertical motor axis) to prevent it from falling by gravity in case the servo power is lost.

<Caution>

The holding brake is to hold the work, not stop its motion. Never use the brake for decelerating and stopping the machine.

Wiring (Example)

This circuit shows a function of controlling the brake using the brake release signal (BRK-OFF) from the driver.

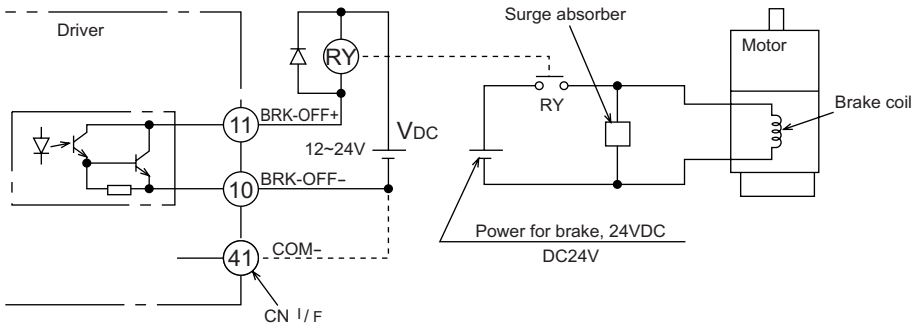

<Notes and Cautions>

1. The brake coil has no polarities.
2. The power supply for the brake should be supplied by the customer. Do not use the control power (VDC) for driving the brake.
3. Install a surge absorber per the figure above in order to suppress the surge voltage due to the on/off operation of the relay (RY). If you use a diode for surge absorber, note that the start of the servo motor after releasing the brake is delayed.
4. Use the recommended surge absorber. See Recommended Parts in page 84.

Holding brake

BRK-OFF Signal

- See Timing Chart describing the timing of issuing BRK-OFF signal, e.g. to release the brake after power-on, and activate the brake in case a servo-off/alarm occurs during the operation of the motor.
- The timing (delay) of deactivating BRK-OFF signal (i.e. activating the brake) after the motor is freed into a non-excited status in case of Servo-OFF or alarm event can be adjusted by using Pr6B (brake output delay time set-up at motor in motion). For details, see Details of Parameters.

<Notes>

1. The brake may produce a sound (rattling of brake liner). This is not a problem.
2. When energizing the brake coil (when the brake is off), magnetic flux may leak from the end of the axis. If a magnetic sensor or similar device is used near the motor, make sure that the device is not affected by the magnetic flux.

Holding Brake Specifications

Motor	Capacity	Static friction torque (N•m)	Inertia x 10 ⁴ (kg•m ²)	Absorption time (ms)	Releasing time (ms) *1	Excitation current (DC current (A)) (during cooling)	Releasing voltage	Allowable thermal equivalent of work per braking (J)	Allowable overall thermal equivalent of work(x103 J)
MSMA	30W ~ 100W	0.29 or more	0.003	25 or less	20 or less 15 or less	0.26	1VDC or more	39.2	4.9
	200W, 400W	1.27 or more	0.03	50 or less		0.36		137	44.1
	750W	2.45 or more	0.09	60 or less		0.43		196	147
MQMA	100W	0.29 or more	0.03	50 or less		0.29		137	44.1
	200W, 400W	1.27 or more	0.09	60 or less		0.41		196	147
MSMA	1kW	4.9 or more	0.25	50 or less		0.74	2VDC or more	392	196
	1.5kW ~ 2.5kW	7.8 or more	0.33	80 or less		0.81			
	3kW, 3.5kW	11.8 or more							
MSMA	4kW ~ 5kW	16.1 or more	1.35	110 or less	50 or less	0.90		1470	2156
	MDMA	750W	7.8 or more	0.33	50 or less	15 or less	0.81	392	490
		1kW	4.9 or more	1.35	80 or less	70 or less	0.59	588	784
MDMA	1.5kW, 2kW	13.7 or more		100 or less	50 or less	0.79	1176	1470	
	2.5kW, 3kW	16.1 or more		110 or less		0.90	1470	2156	
	3.5kW, 4kW	21.5 or more		4.25	90 or less	35 or less	1.10	1078	2450
	4.5kW, 5kW	24.5 or more	4.7	80 or less	25 or less	1.30	1372	2940	
	MHMA	500W, 1kW	4.9 or more	1.35	80 or less	70 or less	0.59	588	784
1.5kW		13.7 or more	100 or less	50 or less		0.79	1176	1470	
2kW ~ 5kW		24.5 or more	4.7	25 or less		1.30	1372	2940	
MFMA	400W	4.9 or more	1.35	150 or less	70 or less	0.59	588	784	
	750W, 1.5kW	7.8 or more	4.7		35 or less	0.83	1372	2940	
	2.5kW, 3.5kW	21.6 or more	8.75		100 or less	0.75	1470	1470	
	4.5kW	31.4 or more					2156		
MGMA	300W	4.9 or more	1.35	80 or less	70 or less	0.59	588	784	
	600W, 900W	11.8 or more	4.7		15 or less	0.81	392	490	
	1.2kW, 2kW	24.5 or more			25 or less	1.3	1372	2940	
	3kW, 4.5kW	58.8 or more	150 or less		50 or less	1.4			

Excitation voltage should be 24VDC ± 10%

*1) Delay of DC cutoff in case a surge absorber is used.

The values in this table are representative (except the friction torque, releasing voltage and excitation voltage). The backlash of the brake is factory-set to within ±1 degree.

Dynamic Brake (DB)

The driver has a dynamic brake for emergency use. Observe the following precautions.

<Notes>

1. The dynamic brake should be used for emergency stop only.

Do not start or stop the motor by switching servo-on signal on or off.

Otherwise the dynamic brake circuit may be broken.

2. The dynamic brake should be on for just a short time for emergency. If the dynamic brake is activated during a high-speed operation, leave the motor stopped for at least three minutes.

The dynamic brake can be used in the following cases.

- A Main power OFF.
- B Servo-OFF
- C One of the protective functions is activated.
- D Over-travel Inhibit (CWL or CCWL) is activated.

In any of four cases above, the dynamic brake can be activated either during deceleration or after stop, or can be made disabled (i.e. allowing the free running of the motor). These features can be set by using the relevant parameters. However, if the control power is OFF, the dynamic brake is kept ON overriding the parameter settings in case the driver is Type 1, 2, 3 or 4; if the driver is type 5, the dynamic brake is not activated overriding the parameter settings.

A Options of the operation through deceleration and stop by turning off the main power (Pr67)

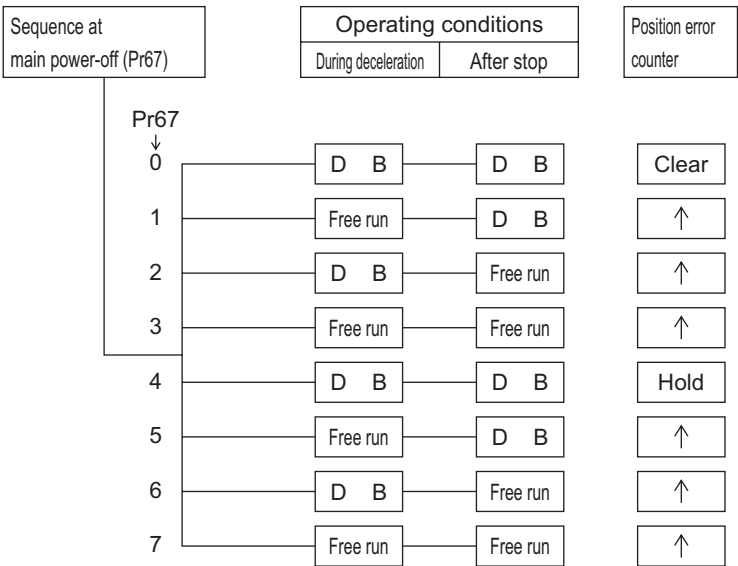

B Options of the operation through deceleration and stop by turning on Servo-OFF (Pr69)

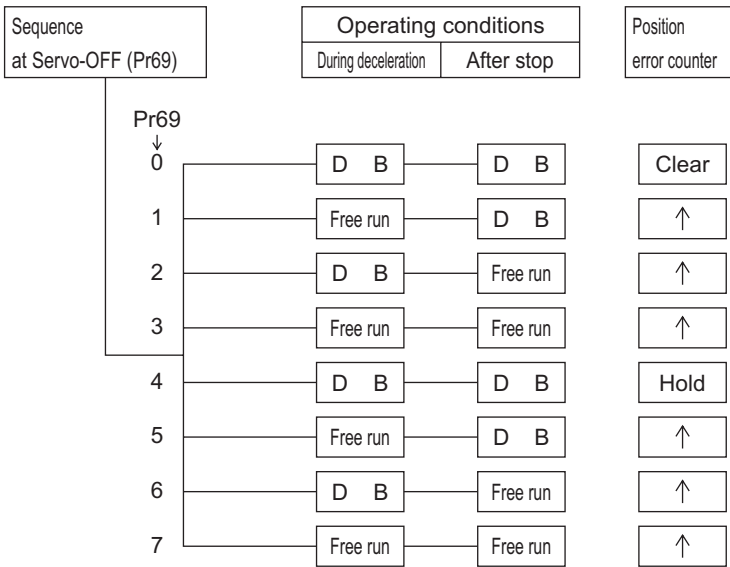

C Options of the operation through deceleration and stop by turning on a protective function (Pr68)

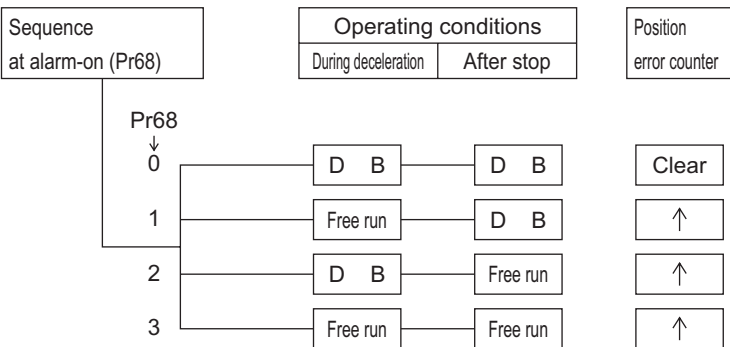

D Options of the operation through deceleration and stop by turning on Over-travel Inhibit (CWL or CCWL) (Pr66)

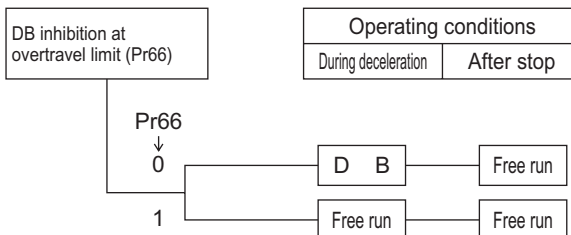

Timing Chart

After Power ON (receiving Servo-ON signal)

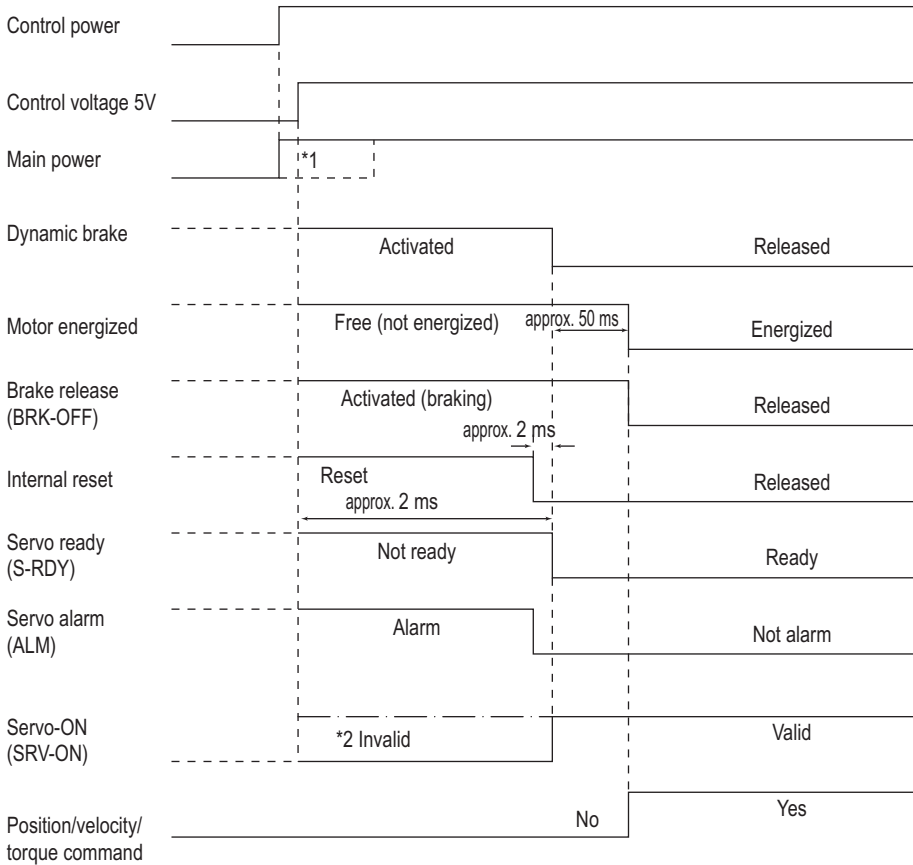

<Notes>

*1. The main power should be turned on at the same time or after turning on the control power.

*2. This means that SRV-ON signal is entered mechanically, but not accepted actually.

After an Alarm event (during Servo-ON)

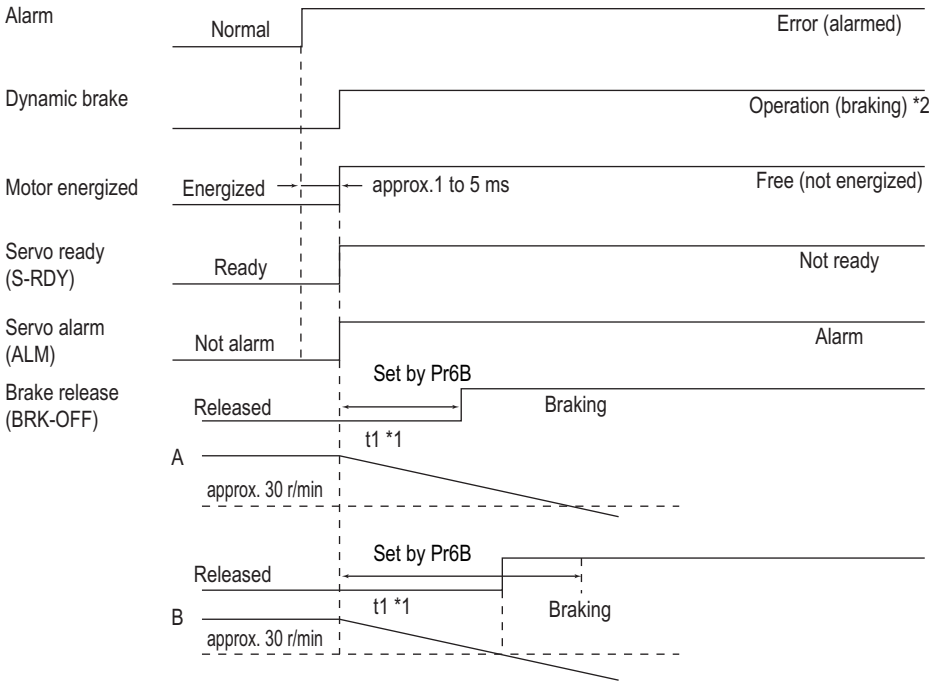

*1. The value of $t1$ is the value of Pr6B or the time needed for decreasing the motor speed to approx. 30 r/min, which is shorter.

*2. For the operation of the dynamic brake following an alarm event, see the explanation of Pr68 in "Details of Parameters".

Timing Chart

After an Alarm is cleared (during Servo-ON)

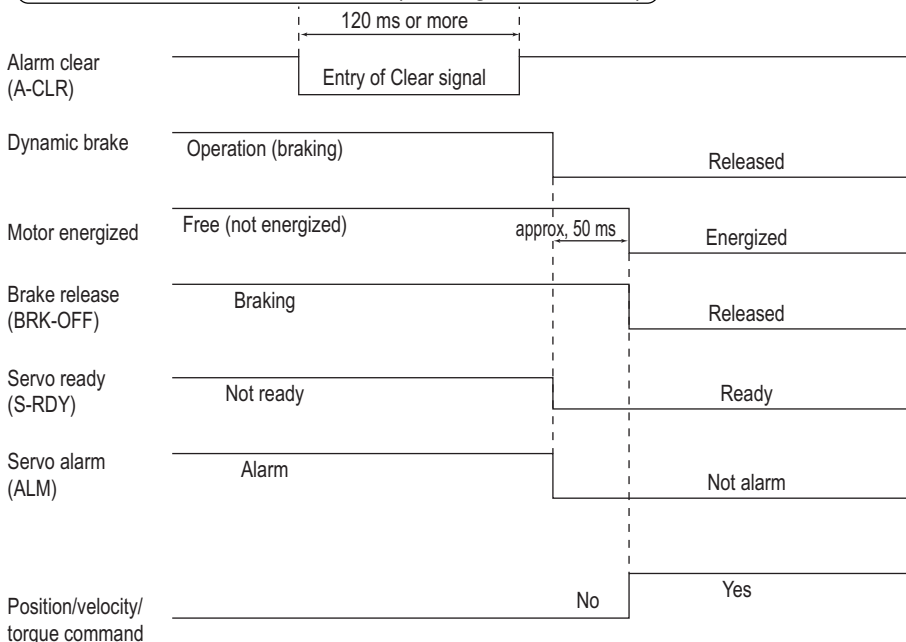

Servo-ON/OFF operation when the motor is stopped

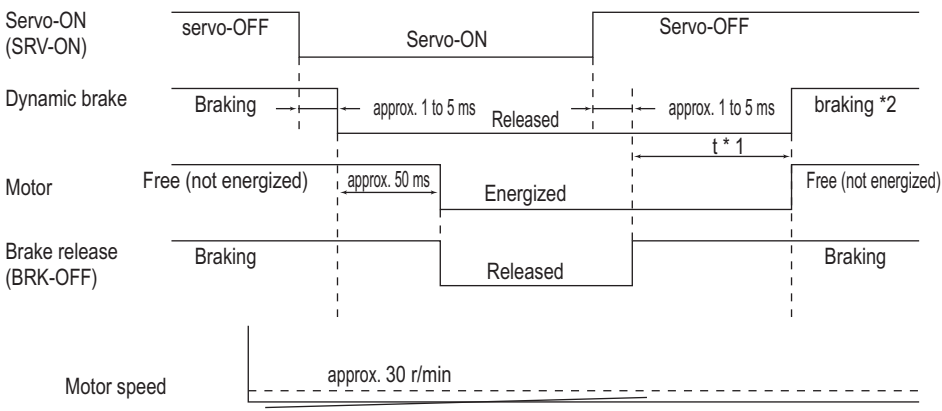

*1. The value of t depends on the value of Pr6A.

*2. For the operation of the dynamic brake at Servo-OFF, see the explanation of Pr69 in "Details of Parameters".

Servo-ON/OFF operation when the motor is in operation

With Servo-ON entered

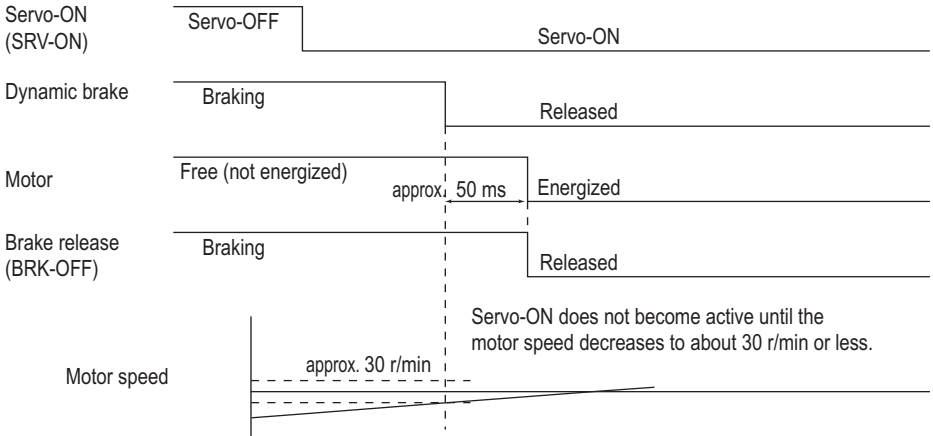

With Servo-OFF entered

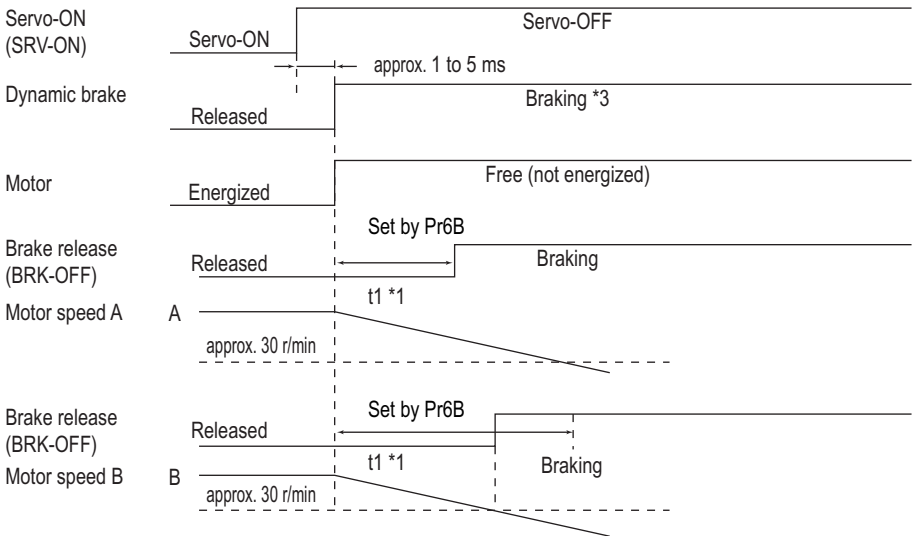

- *1. The value of $t1$ is the value of Pr6B or the time needed for decreasing the motor speed to about 30 r/min, which is shorter.
- *2. During deceleration, Servo-ON does not become active until the motor stops, even if you attempt to turn on SRV-ON again.
- *3. For the operation of the dynamic brake at Servo-OFF, see the explanation of Pr69 in "Details of Parameters".

Acceptable Loads on Output Axes

Acceptable Loads on Output Axes

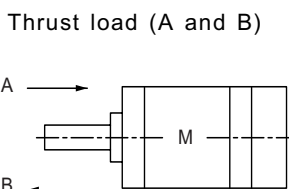
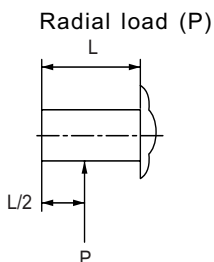

Unit: N (1 kgf = 9.8 N)

Motor series	Motor capacity	Design			Acceptable during operation	
		Radial load	Thrust load		Radial load	Thrust load (A or B direction)
			A direction	B direction		
MSMA	30W	1 4 7	8 8	1 1 7 . 6	4 9	2 9 . 4
	50W, 100W				6 8 . 6	5 8 . 8
	200W, 400W	3 9 2	1 4 7	1 9 6	2 4 5	9 8
	750W	6 8 6	2 9 4	3 9 2	3 9 2	1 4 7
MQMA	100W	1 4 7	8 8	1 1 7 . 6	6 8 . 6	5 8 . 8
	200W, 400W	3 9 2	1 4 7	1 9 6	2 4 5	9 8
MSMA	1kW	6 8 6	3 9 2	4 9 0	3 9 2	1 4 7
	1.5kW ~ 3.5kW	9 8 0	5 8 8	6 8 6	4 9 0	1 9 6
	4kW ~ 5kW				7 8 4	3 4 3
MDMA	750W	6 8 6	3 9 2	4 9 0	3 9 2	1 4 7
	1kW ~ 2kW	9 8 0	5 8 8	6 8 6	4 9 0	1 9 6
	2.5kW, 3kW				7 8 4	3 4 3
	3.5kW, 4kW	1 6 6 6	7 8 4	9 8 0		
	4.5kW, 5kW					
MHMA	500W ~ 1.5kW	9 8 0	5 8 8	6 8 6	4 9 0	1 9 6
	2kW ~ 5kW	1 6 6 6	7 8 4	9 8 0	7 8 4	3 4 3
MFMA	400W	9 8 0	5 8 8	6 8 6	3 9 2	1 4 7
	750W, 1.5kW				4 9 0	1 9 6
	2.5kW ~ 4.5kW	1 8 6 2	6 8 6		7 8 4	2 9 4
MGMA	300W ~ 900W	9 8 0	5 8 8		4 9 0	1 9 6
	1.2kW ~ 3kW	1 6 6 6	7 8 4	9 8 0	7 8 4	3 4 3
	4.5kW	2 0 5 8	9 8 0	1 1 7 6	1 1 7 6	4 9 0

Initialization (Precautions)

- In the operation of initialization (returning to the home position), if the initialization signal (Z-phase signal from the encoder) is entered before the motor is not substantially decelerated (after the proximity sensor is activated), the motor may not stop at the required position. To avoid this, determine the positions with the proximity sensor on and initialization signal on in consideration of the number of pulses required for successful deceleration. The parameters for setting the acceleration/deceleration time also affect the operation of initialization, so that these parameters should be determined in consideration of both the positioning and initializing operations.

The motor will start to decelerate with the proximity sensor ON, and stop with the first initialization signal (Z-phase).

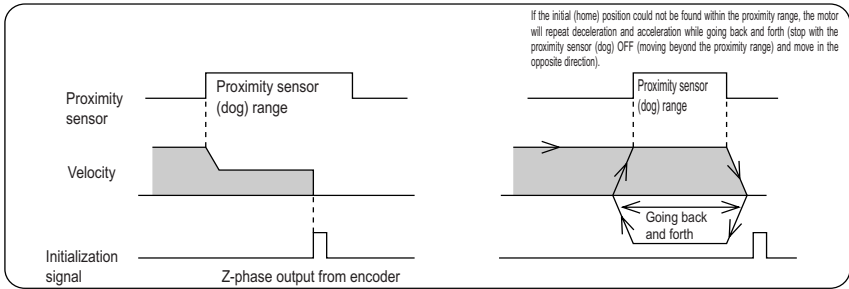

The motor will start to decelerate with the proximity sensor ON, and stop with the first initialization Z-phase signal after the proximity sensor OFF.

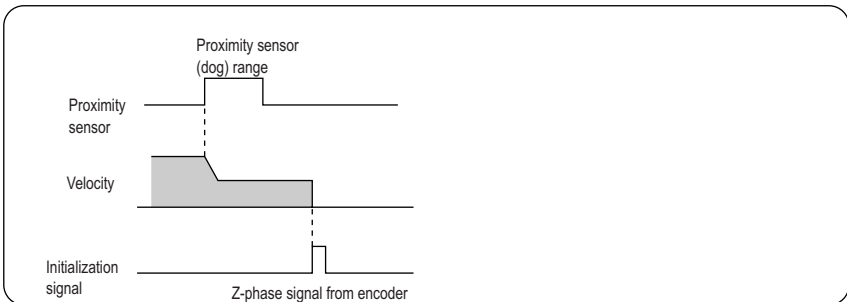

"Absolute" Driver

In case of using an absolute encoder, or in case of using an absolute/incremental encoder as an absolute encoder, connect a battery for operating the absolute encoder, and set Pr0B (absolute encoder set-up) to 0. With this setting, the controller can know the current position of the motor, and the absolute system without any operation of initialization will become available.

Initializing the Encoder

Before using the driver-motor system, it is necessary to clear (initialize) the encoder at the home position. With this operation, the value of the multi-turn counter will become 0. For this operation, use the LED touch panel (auxiliary function: absolute encoder clear mode) or PANATERM (DVOP1950). After this operation, you must turn off the control power and turn it on again to save the data in the encoder.

Absolute Data

The absolute data consist of: Single-turn data that defines the absolute position of the motor, and Multi-turn data that counts the number of turns after the latest clearing operation of the encoder.

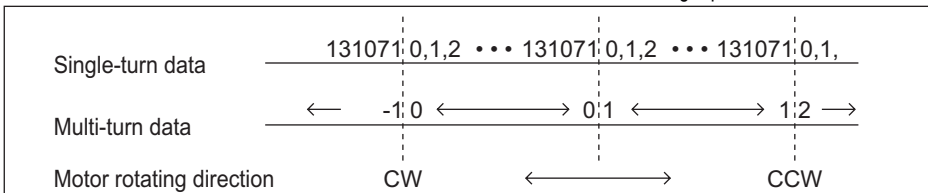

Structure of Absolute Data

The single- and multi-turn data consist of 15-character data (hexadecimal binary code) from the RS232C or RS485 communication interface. For the communication procedure, see pages 23 and 25 in Appendix.

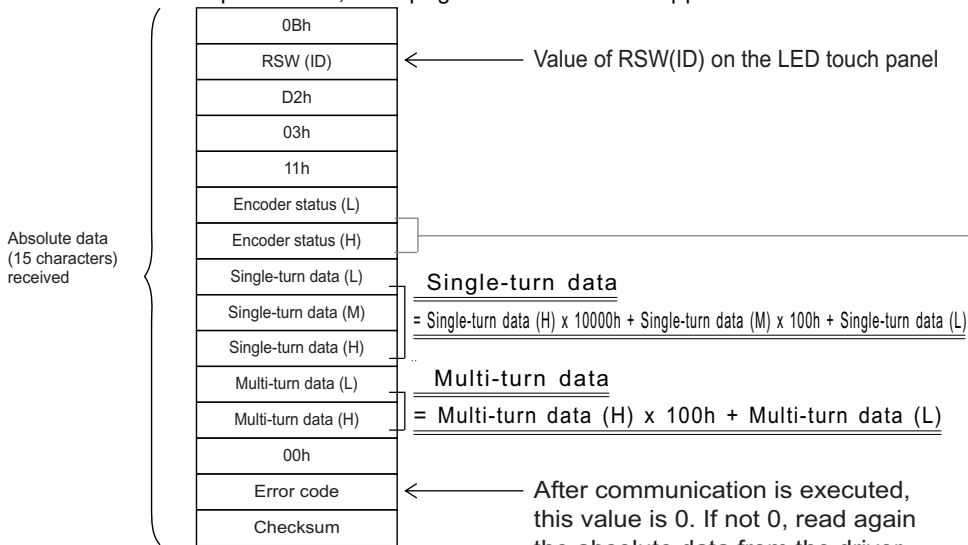

Encoder status (1 means the occurrence of an error)

Encoder status (L)							
Bit 7	Bit 6	Bit 5	Bit 4	Bit 3	Bit 2	Bit 1	Bit 0
			0				

- Over-speed → Err42
(absolute over-speed error)
- Full absolute status → Err47
(absolute status error)
- Count error → Err44
(absolute single-turn counter error)
- Counter overflow → Err41
(absolute counter overflow error)
- Multi-turn counter error → Err45
(absolute multi-turn counter error)
- Battery error → Err40
(absolute system down error)
- Battery alarm → Battery alarm

Encoder status (H)							
Bit 7	Bit 6	Bit 5	Bit 4	Bit 3	Bit 2	Bit 1	Bit 0
0	0			0	0	0	0

- Battery error
- Occurrence of battery alarm, multi-turn counter error, counter over, counter error, full absolute status or over-speed

For details of the encoder status, see Encoder Specifications.

- For details of the transfer of absolute data, see Communication Specifications.
- When transferring absolute data, enter Servo-OFF and fix the motor using a brake.

Installing the Battery

The backup battery is used for saving the position data of the absolute encoder when the main power of the driver is off. Use one of the following methods for connecting the battery.

- 1 Install the battery at the controller side.
- 2 Install the battery in the driver.
- 3 Install the battery at the motor side.

If the encoder cable must be removed and then reconnected at the installation site, apply the method 3 (Install the battery at the motor side) so that the encoder can be powered continually.

"Absolute" Driver

RS232C Communication Protocol

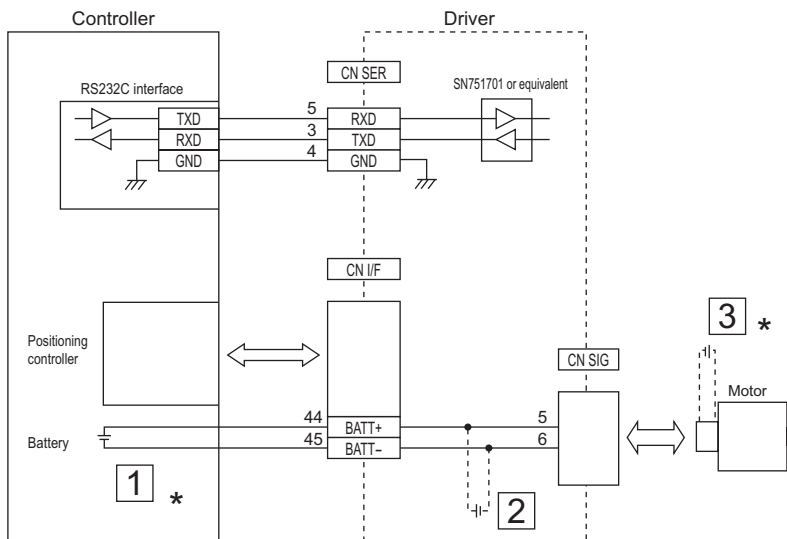
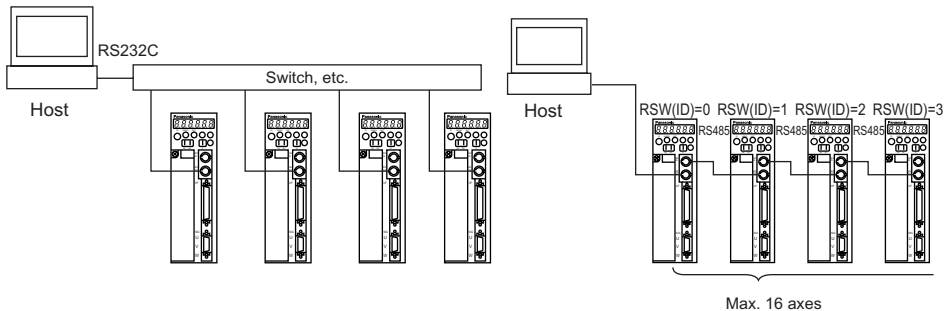

* For battery connection, see Installing the Battery in the previous page.

Baud rate	2400, 4800, 9600bps
Data length	8 bits
Parity	Nil
Start bit	1 bit
Stop bit	1 bit

The baud rate is determined by Parameter No.0C (Baud rate set-up of RS232C).

RS232C Communication Protocol

For the transfer of commands, see the instructions of the controller.
RS232C communication is possible with Servo Ready output ON.

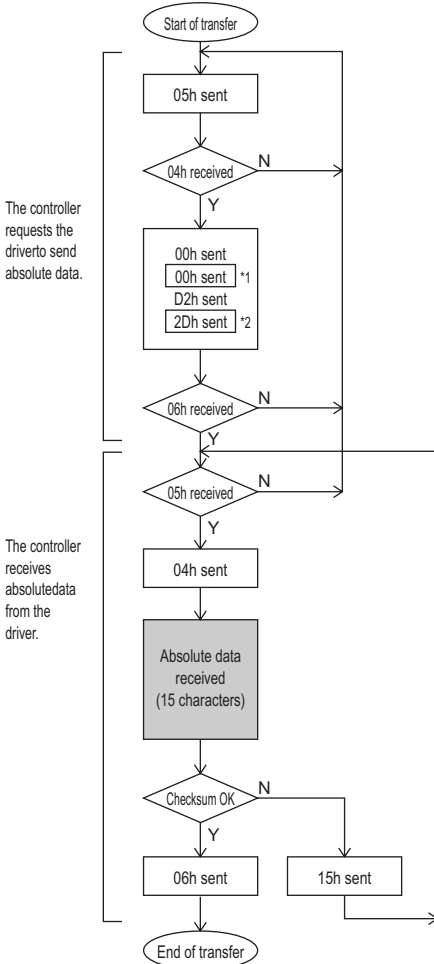

*1 and *2 data depend on the value of RSW(ID) on the LED touch panel.

RSW(ID)	*1 data	*2 data
0	00 h	2E h
1	01 h	2D h
2	02 h	2C h
3	03 h	2B h
4	04 h	2A h
5	05 h	29 h
6	06 h	28 h
7	07 h	27 h
8	08 h	26 h
9	09 h	25 h
A	0A h	24 h
B	0B h	23 h
C	0C h	22 h
D	0D h	21 h
E	0E h	20 h
F	0F h	1F h

Checksum: OK if the value of the lowest 8 bits of the sum of the received absolute data (15 characters) is 0.

The host enters the RSW value (*1 data) of the desired driver into the "axis" field of the command block, and sends the command according to the RS232C communication protocol.

"Absolute" Driver

RS485 Connection

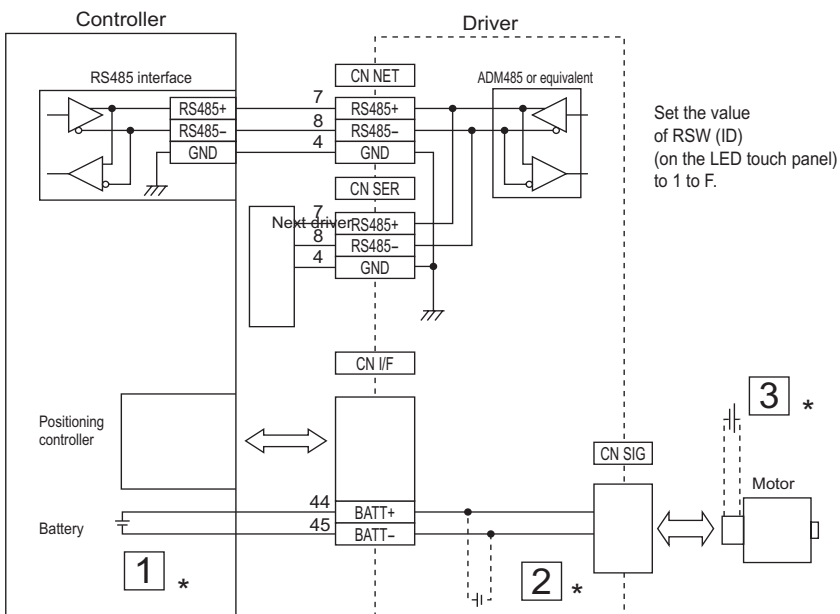
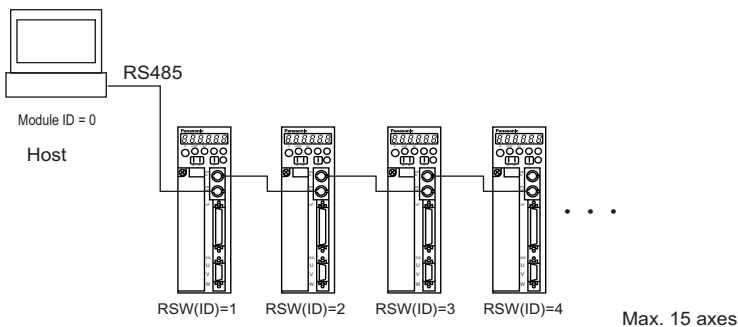

* For battery connection, see Installing the Battery in the previous page.

Baud rate	2400, 4800, 9600 bps
Data length	8 bits
Parity	Nil
Start bit	1 bit
Stop bit	1 bit

The baud rate is determined by Parameter No.0D (Baud rate set-up of RS485).

RS485 Communication Protocol

For the transfer of commands, see the instructions of the controller.

RS485 communication is possible with Servo Ready output ON.

The following flow chart shows the communication when RSW(ID) = 1.

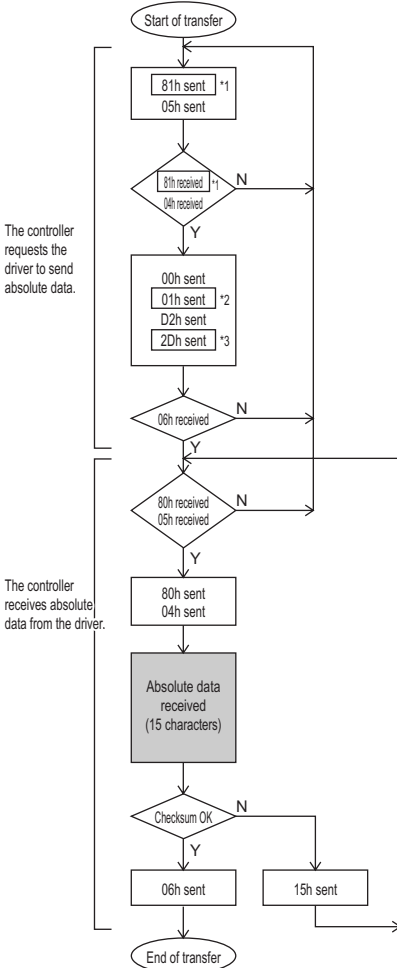

*1, *2 and *3 data depend on the value of RSW(ID) on the LED touch panel.

RSW(ID)	*1 data	*2 data	*3 data
0	RS485 is not available		
1	8 1 h	0 1 h	2 D h
2	8 2 h	0 2 h	2 C h
3	8 3 h	0 3 h	2 B h
4	8 4 h	0 4 h	2 A h
5	8 5 h	0 5 h	2 9 h
6	8 6 h	0 6 h	2 8 h
7	8 7 h	0 7 h	2 7 h
8	8 8 h	0 8 h	2 6 h
9	8 9 h	0 9 h	2 5 h
A	8 A h	0 A h	2 4 h
B	8 B h	0 B h	2 3 h
C	8 C h	0 C h	2 2 h
D	8 D h	0 D h	2 1 h
E	8 E h	0 E h	2 0 h
F	8 F h	0 F h	1 F h

Checksum : OK if the value of the lowest 8 bits of the sum of the received absolute data (15 characters) is 0.

The host sends the command to the desired driver according to the RS485 communication protocol.

"Absolute" Driver

How to install the battery

1. Cut away the upper right corner of the terminal block cover for types 1 through 3

1 Remove the screw.

2 Remove the cover, and cut away its upper right corner.

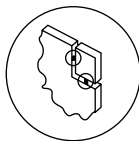

Use nippers.

3 Replace the cover, and tighten the screw.

Terminal block cover

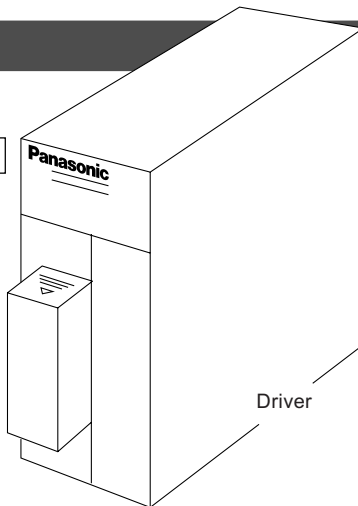

Driver

2. Insert the battery into the holder.

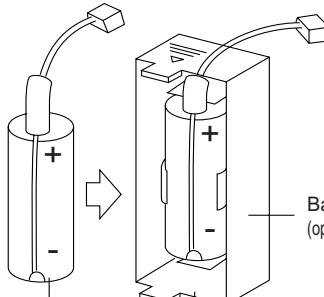

Battery holder
(optional: DVOP2061)

3. Set the holder to the driver.

Battery
DVOP2060

1 Insert the battery

1 Connect the cable.

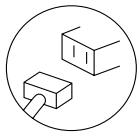

2 Set the lug into place.

3 Snap the upper lug into place while pressing the  mark.

Battery holder

Note:
Make sure that the cable is not caught between the driver and holder.

1. Remove the battery cover for Types 4-2, 4-3 and 5

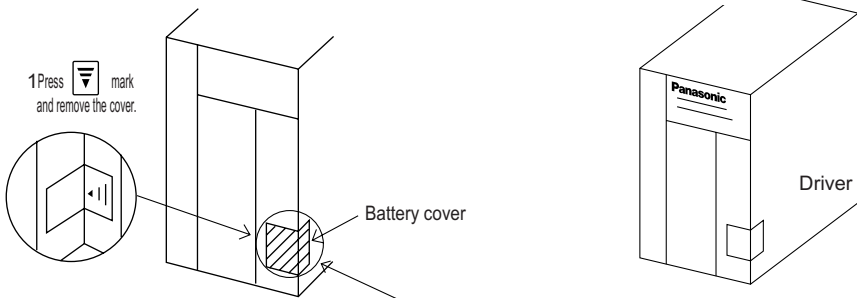

2. Set the battery into the holder.

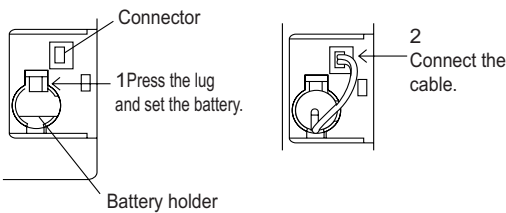

3. Snap the battery cover into place

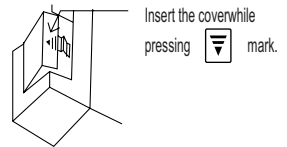

<Notes>

If using two batteries simultaneously, one at the driver and other one at the controller, a loop circuit is made, which may cause troubles.

1. Never use a damaged (liquid leaking) battery.
2. Make sure that the battery cable is firmly connected. Otherwise electric contact may be lost due to aging.

"Full Close" Driver

Combining a certain type of the driver with an external scale (linear type), you can use the full-close driver for precise positioning.

Drivers available for "full-close" use are the 17-bit absolute driver and 17-bit absolute/incremental driver. details, see Full-Close Specifications.

Wiring of main circuit

For wiring, see page 22.

CN SIG Connector

MSMA (750W or less) and MQMA

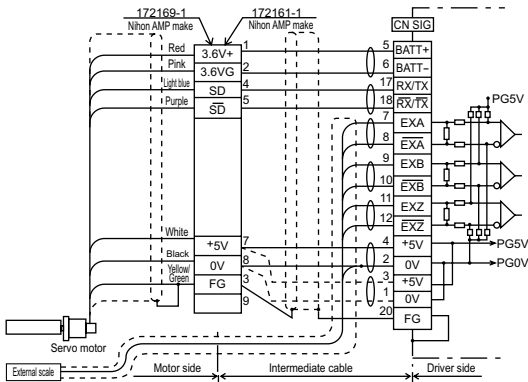

MSMA (1kW or more), MDMA, MFMA, MHMA and MGMA

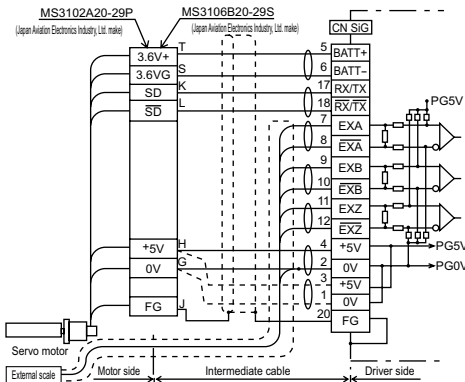

<Note>

Please prepare the electrical power for the external scale.

CN I/F Connector

See Full-Close Specifications.

For wiring, see page 28.

Parameter Listing

See Full-Close Specifications.

Connection to an external scale

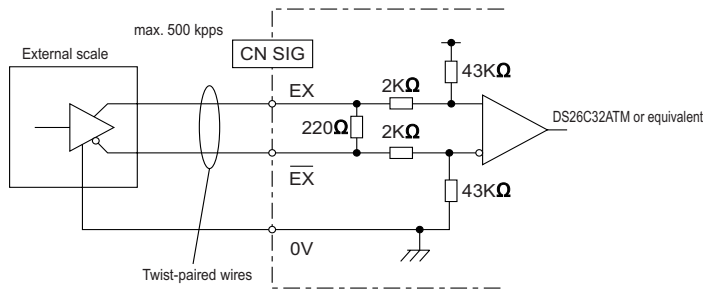

• Relationship between signal from external scale and rotating direction

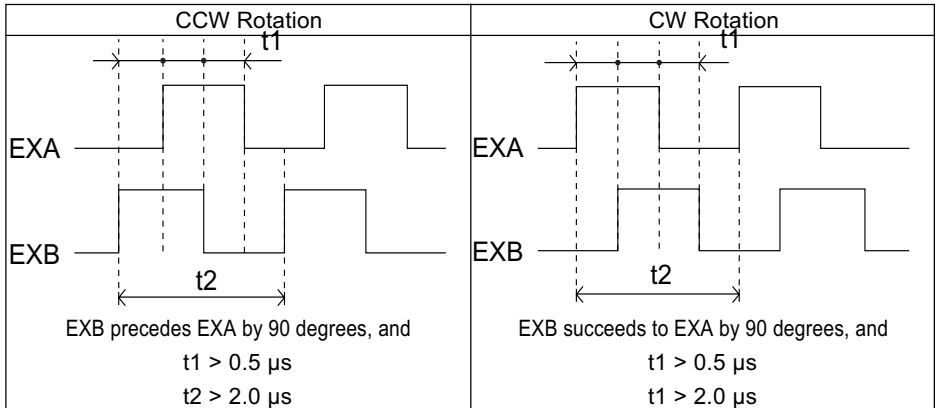

Details of Parameters

Parameters for Function Selection

Default setting is shown by []

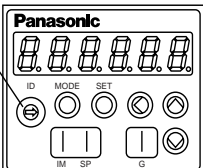
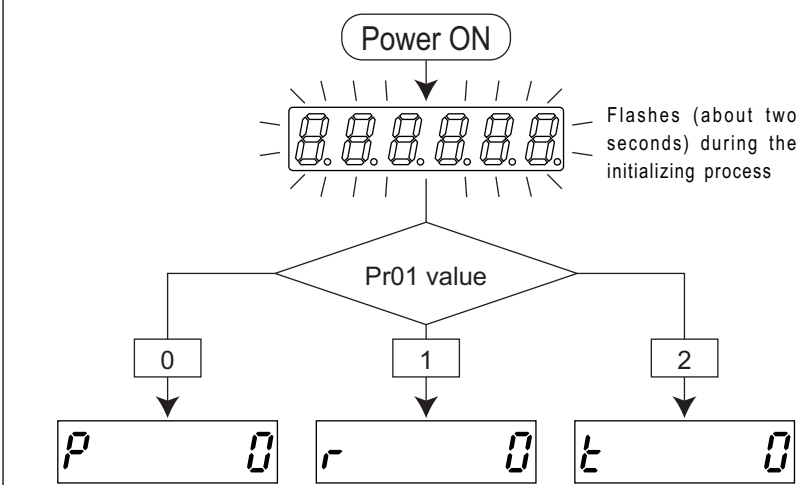
PrNo.	Parameter	Value	Function							
0 0	Axis address	0 ~ 15 [1]	<p>If multiple axes are used, it is necessary for the river to identify the current axis that is accessed by the host (e.g. PC). You can identify axis address by number with this parameter.</p> <ul style="list-style-type: none"> With the mains power ON, the current value of RSW ID (0 to F) on the LED touch panel is downloaded to the driver as the value of this parameter. The value of this parameter cannot be modified by other means than the rotary switch (RSW) ID. 							
0 1	Initial LED status	0 ~ 2 [1]	<p>You can select the type of information to be displayed initially on the 7-segment LED at power on.</p>  <p>Flashes (about two seconds) during the initializing process</p> <table border="1"> <tr> <td rowspan="2">Displayed information</td> <td>Reading (pulse count) of the position error counter Unit: pulse</td> <td>Motor speed Unit : r/min.</td> <td>Motor torque Unit : %</td> </tr> <tr> <td> + : generates CCW-torque - : generates CW-torque </td> <td> + : runs in CCW - : runs in CW </td> <td> + : generates CCW-torque - : generates CW-torque </td> </tr> </table>	Displayed information	Reading (pulse count) of the position error counter Unit: pulse	Motor speed Unit : r/min.	Motor torque Unit : %	+ : generates CCW-torque - : generates CW-torque	+ : runs in CCW - : runs in CW	+ : generates CCW-torque - : generates CW-torque
Displayed information	Reading (pulse count) of the position error counter Unit: pulse	Motor speed Unit : r/min.	Motor torque Unit : %							
	+ : generates CCW-torque - : generates CW-torque	+ : runs in CCW - : runs in CW	+ : generates CCW-torque - : generates CW-torque							

PrNo.	Parameter	Value	Function																							
0 2	Control mode set-up	0 ~ 10 [1]	You can set the control mode to be used.																							
			<table border="1"> <thead> <tr> <th rowspan="2">Value</th> <th colspan="2">Control mode</th> </tr> <tr> <th>1st mode</th> <th>2nd mode *2</th> </tr> </thead> <tbody> <tr> <td>0</td> <td>Position</td> <td>—</td> </tr> <tr> <td>1</td> <td>Velocity</td> <td>—</td> </tr> <tr> <td>2</td> <td>Torque</td> <td>—</td> </tr> <tr> <td>3</td> <td>Position</td> <td>Velocity</td> </tr> <tr> <td>4</td> <td>Position</td> <td>Torque</td> </tr> <tr> <td>5</td> <td>Velocity</td> <td>Torque</td> </tr> <tr> <td>6 ~ 10</td> <td colspan="2">*1</td> </tr> </tbody> </table>	Value	Control mode		1st mode	2nd mode *2	0	Position	—	1	Velocity	—	2	Torque	—	3	Position	Velocity	4	Position	Torque	5	Velocity	Torque
Value	Control mode																									
	1st mode	2nd mode *2																								
0	Position	—																								
1	Velocity	—																								
2	Torque	—																								
3	Position	Velocity																								
4	Position	Torque																								
5	Velocity	Torque																								
6 ~ 10	*1																									
			<p>*1 These are special modes intended for "full-close" operation. For details, see Full-Close Specifications.</p> <p>*2 If a hybrid mode has been selected (Pr02 = 3, 4, 5, 9 or 10), switch the 1st. and 2nd. mode with the control mode switching input(C-MODE).</p> <p>Notes</p> <p>Allow 10ms or longer before entering any commands, after entering C-MODE.</p>																							
0 3	Analogue torque limit inhibit	0 ~ 1 [1]	You can disable the analogue torque limit input (CCWTL or CWTL). 1∆Input disabled 0∆Input enabled																							
			If you do not use the torque limit, set Pr03 to 1. With Pr03 = 0 and torque limit input (CCWTL and CWTL) open, the motor does not run.																							

Details of Parameters

PrNo.	Parameter	Value	Function																						
0 4	Overtravel input inhibit	0 ~ 1 [1]	<p>For linear motion or other similar motion, overtraveling of the work may cause mechanical damages. To avoid this, it is necessary to provide a limit switches at each end so that traveling over the limit switch position can be inhibited.</p>																						
			<table border="1"> <thead> <tr> <th>Value</th> <th>CCWL/CWL input</th> <th>Input</th> <th>Connection to COM-</th> <th>Operation</th> </tr> </thead> <tbody> <tr> <td rowspan="4">0</td> <td rowspan="4">Enabled</td> <td rowspan="2">CCWL AiCN I/F-9Aj</td> <td>Disabled</td> <td>Normal with the CCW limit switch not activated</td> </tr> <tr> <td>Open (H)</td> <td>Traveling in CCW direction limited, CW direction allowed</td> </tr> <tr> <td rowspan="2">CWL AiCN I/F-8Aj</td> <td>Connection (L)</td> <td>Normal with the CW limit switch not activated</td> </tr> <tr> <td>Open (H)</td> <td>Traveling in CW direction limited, CCW direction allowed</td> </tr> <tr> <td>1</td> <td>Disabled</td> <td colspan="3">Both the CCWL and CWL inputs are disabled, and traveling in both the CW and CCW directions are allowed.</td> </tr> </tbody> </table> <p><Notes></p> <ol style="list-style-type: none"> With Pr04 = 0 and CCW/CW off (not connected to COM-), the driver will trip with "overtravel limit input error" assuming that traveling over the limit occurs simultaneously in both the CCW and CW directions. You can specify whether or not to use the dynamic brake during deceleration after CCW or CW overtravel limit input (CCWL or CWL) becomes active. For details, see the description of Pr66 (DB inhibition at overtravel limit). 	Value	CCWL/CWL input	Input	Connection to COM-	Operation	0	Enabled	CCWL AiCN I/F-9Aj	Disabled	Normal with the CCW limit switch not activated	Open (H)	Traveling in CCW direction limited, CW direction allowed	CWL AiCN I/F-8Aj	Connection (L)	Normal with the CW limit switch not activated	Open (H)	Traveling in CW direction limited, CCW direction allowed	1	Disabled	Both the CCWL and CWL inputs are disabled, and traveling in both the CW and CCW directions are allowed.		
Value	CCWL/CWL input	Input	Connection to COM-	Operation																					
0	Enabled	CCWL AiCN I/F-9Aj	Disabled	Normal with the CCW limit switch not activated																					
			Open (H)	Traveling in CCW direction limited, CW direction allowed																					
		CWL AiCN I/F-8Aj	Connection (L)	Normal with the CW limit switch not activated																					
			Open (H)	Traveling in CW direction limited, CCW direction allowed																					
1	Disabled	Both the CCWL and CWL inputs are disabled, and traveling in both the CW and CCW directions are allowed.																							

PrNo.	Parameter	Value	Function
0 5	Internal speed switching	0 ~ 2 [0]	• You can easily set-up the internal speed with contact inputs only.

- You can select whether to enable or disable the internal velocity set-up.
- There are four options of internal velocity commands: Pr53 (1st speed), Pr54 (2nd speed), Pr55 (3rd speed) and Pr56 (4th speed).
- Block diagrams of the internal and external velocity set-up functions

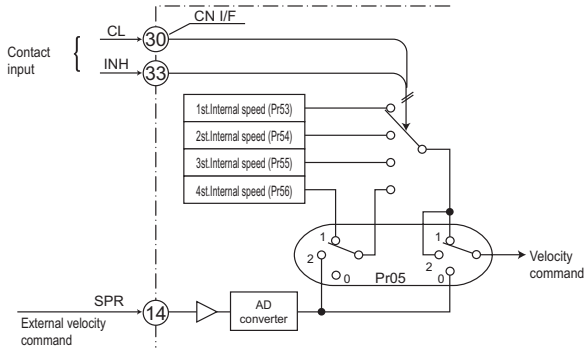

- Switching between the four options of internal velocity commands uses two contact inputs. Example: 4-speed operation using the internal velocity commands To run/stop the motor, you need zero speed clamp input(ZEROSPD) and Servo-ON input(SRV-ON) in addition to CL/INH input.

A INH (CN I/F Pin 33): Internal velocity command select 1

B CL (CN I/F Pin 30): Internal velocity command select 2

INH (Pin 33)	CL (Pin 30)	Value of Pr05		
		0	1	2
Off	Off	External velocity command	1st Internal speed (Pr53)	←
On	Off	↑	2st Internal speed (Pr54)	←
Off	On	↑	3st Internal speed (Pr55)	←
On	On	↑	4st Internal speed (Pr56)	External velocity command

Details of Parameters

PrNo.	Parameter	Value	Function
0 5 (continued)	Internal speed switching		<p>• Example: 4-speed operation using the internal velocity commands To run/stop the motor, you need zero speed clamp input(ZEROSPD) and Servo-ON input(SRV-ON) in addition to CL/INH input.</p> <p>SER-ON input Servo-On</p> <p>ZEROSPD input Stop Operation</p> <p>INH input Off On Off On</p> <p>CL input Off Off On On</p> <p>Velocity</p> <p>1st speed 2nd speed 3rd speed 4th speed</p> <p>Time</p> <p><Notes> You can set-up the acceleration/deceleration time, and S-curve acceleration/deceleration time individually with parameters. See the following descriptions of the parameters: Pr58 (Acceleration time set-up) Pr59 (Deceleration time set-up) Pr5A (S-shaped accel/decel time set-up)</p>
0 6	ZEROSPD input selection	0 ~ 1 [0]	You can switch whether to enable or disable the zero speed clamp input (ZEROSPD, CN I/F Pin 26).
	Value	Function of ZEROSPD input (Pin 26)	
	0	The ZEROSPD input is disabled, and the driver assumes that the motor is always "not clamped to zero speed".	
	1	The ZEROSPD input is enabled, and the velocity command is regarded as "0", by opening the connection to COM- .	

PrNo.	Parameter	Value	Function				
0 7	Speed monitor(SP) selection	0 ~ 9 [3]	You can select/set-up the relationship between the voltage to be fed-out to the speed monitor signal output (SPM: CN I/F Pin 43) and the actual speed (or command velocity) of the motor.				
		Value	SPM signal	Relationship between output voltage level and velocity			
		0	Actual motor speed	6V / 47 r/min			
		1		6V / 187 r/min			
		2		6V / 750 r/min			
		3		6V / 3000 r/min			
		4		1.5V / 3000 r/min			
		5	Commanded velocity	6V / 47 r/min			
		6		6V / 187 r/min			
		7		6V / 750 r/min			
8	6V / 3000 r/min						
9	1.5V / 3000 r/min						
0 8	Torque monitor (IM)selection	0 ~ 5 [0]	You can select/set-up the relationship between the voltage to be fed-out to torque monitor signal output (IM: CN I/F Pin 42) and the actual torque of the motor or position error pulse counts.				
		Value	SPM signal	Relationship between output voltage and torque or position error pulse counts			
		0	Torque	3V / rated torque (100%)			
		1	Position error pulse counts	3V / 31 Pulse			
		2		3V / 125 Pulse			
		3		3V / 500 Pulse			
		4		3V / 2000 Pulse			
		5		3V / 8000 Pulse			
		6 ~ 10		Enabled at full-close control (see Full-Close Specifications)			
		0 9	TLC output selection	0 ~ 5 [0]	You can define the functions of the torque limit output (TLC: CN I/F pin 40).		
Varue	Function					Signal symbol	Remarks
0	Torque in-limit					TLC	
1	Zero speed detection					ZSP	
2	Alarm signal					WARN ALL	
3	Overregeneration alarm					WARN REG	
4	Overload alarm					WARN OL	
5	Absolute battery alarm					WARN BATT	
				For details of these functions, see the section of CN I/F Connector.			

Details of Parameters

PrNo.	Parameter	Value	Function								
0 A	ZSP output selection	0 ~ 5 [1]	<p>You can define the functions of the zero speed detection output (ZSP: CN I/F pin 12).</p> <p>The relationship between Pr0A value and ZSP output is the same as that of Pr09 (TLC).</p>								
0 B	Absolute encoder set-up	0 ~ 2 [1]	<p>Use this when using an absolute encoder.</p> <table border="1"> <thead> <tr> <th>Value</th> <th>Description</th> </tr> </thead> <tbody> <tr> <td>0</td> <td>Uses an absolute encoder as an absolute encoder.</td> </tr> <tr> <td>1</td> <td>Uses an absolute encoder as an incremental encoder.</td> </tr> <tr> <td>2</td> <td>Uses an absolute encoder as an absolute encoder (but ignoring the "multi-turn counter over").</td> </tr> </tbody> </table>	Value	Description	0	Uses an absolute encoder as an absolute encoder.	1	Uses an absolute encoder as an incremental encoder.	2	Uses an absolute encoder as an absolute encoder (but ignoring the "multi-turn counter over").
Value	Description										
0	Uses an absolute encoder as an absolute encoder.										
1	Uses an absolute encoder as an incremental encoder.										
2	Uses an absolute encoder as an absolute encoder (but ignoring the "multi-turn counter over").										
0 C	Baud rate set-up of RS232C	0 ~ 2 [2]	<table border="1"> <thead> <tr> <th>Value</th> <th>Baud rate</th> </tr> </thead> <tbody> <tr> <td>0</td> <td>2400bps</td> </tr> <tr> <td>1</td> <td>4800bps</td> </tr> <tr> <td>2</td> <td>9600bps</td> </tr> </tbody> </table>	Value	Baud rate	0	2400bps	1	4800bps	2	9600bps
Value	Baud rate										
0	2400bps										
1	4800bps										
2	9600bps										
0 D	Baud rate set-up of RS485	0 ~ 2 [2]	<table border="1"> <thead> <tr> <th>Value</th> <th>Baud rate</th> </tr> </thead> <tbody> <tr> <td>0</td> <td>2400bps</td> </tr> <tr> <td>1</td> <td>4800bps</td> </tr> <tr> <td>2</td> <td>9600bps</td> </tr> </tbody> </table>	Value	Baud rate	0	2400bps	1	4800bps	2	9600bps
Value	Baud rate										
0	2400bps										
1	4800bps										
2	9600bps										

<Note>

- For the default values of Pr11 and Pr14, see page 44.

Parameters for Time Constants of Gains and Filters: Related to Real Time Auto Tuning

PrNo.	Parameter	Value	Unit	Function
1 0	1st position loop gain	10 ~ 2000 [50]	1/s	<ul style="list-style-type: none"> You can define the response characteristics of position control. Higher the gain you set, quicker the in-position time you can obtain.
1 1	1st velocity loop gain	1 ~ 3500	Hz *	<ul style="list-style-type: none"> To obtain the overall response of the servo system together with the above position gain, set this gain as large as possible.
1 2	1st velocity loop integration time constant	1 ~ 1000 [50]	ms	<ul style="list-style-type: none"> Integration element of the velocity loop. The smaller the setting, the quicker you can reduce the velocity error to 0, after stopping. The integration is disabled by setting this to 1,000.
1 3	1st speed detection filter	0 ~ 5 [4]	%	<ul style="list-style-type: none"> You can set-up the time constant of low-pass filter(LPF) in 6 stages(0 to 5), which is inserted after the block , and which converts the encoder signal to the velocity signal. The higher the value you set-up, the smaller the noise you can obtain, however, it is usually recommended to use the default value (4).
1 4	1st torque filter time constant	0 ~ 2500	0.01ms	<ul style="list-style-type: none"> You can set-up the time constant of the primary delay filter that is inserted to the torque command portion. Use this function to suppress the oscillation caused by torsion resonance.
1 5	Velocity feed forward	0 ~ 100 [0]	%	<p>You can set-up the amount of velocity feed forward at position control. Position error becomes almost 0 while the motor runs at a constant speed, by setting this to 100%. The higher the setting you make, the quicker the response you can obtain with smaller position error, however, it may cause overshoot.</p>
1 6	Feed forward filter time constant	0 ~ 6400 [0]	0.01ms	<ul style="list-style-type: none"> You can set-up the time constant of the primary delay filter that is inserted to the velocity feed forward portion. Use this function to reduce the over and under-shoot of the speed, chattering of the in-position signal.
1 7	(Reserved)			

* See page 38 in Appendix.

Details of Parameters

PrNo.	Parameter	Value	Unit	Function						
1 8	2nd position loop gain	10 ~ 2000 [50]	1/s	<ul style="list-style-type: none"> This driver provides 2(two) sets (1st. and 2nd.) of gain and time constant for position loop, velocity loop, velocity detection filter and torque command filter. The functions and meanings of these 2nd gains or time constants are the same as those of the 1st ones mentioned in the previous page. For switching between the 1st and 2nd gains or constants, see Adjustment. * If Pr20 (inertia ratio) has been set correctly, the unit of the values of Pr11 and Pr19 is Hz. 						
1 9	2nd velocity loop gain	1 ~ 3500	Hz *							
1 A	2nd velocity loop integration time constant	1 ~ 1000 [50]	ms							
1 B	2nd speed detection filter	0 ~ 5 [4]	A[
1 C	2nd torque filter time constant	0 ~ 2500	0.01ms							
1 D	Notch frequency	100 ~ 500 [1500]	Hz	<ul style="list-style-type: none"> You can set-up the frequency of the resonance suppression notch filter. You can set-up the resonance frequency of the machine system which you can obtain by the frequency characteristics analysis program contained in PANATERM. This notch filter function will be disabled by setting this parameter to 1500. 						
1 E	Notch width selection	0 ~ 4 [2]	—	<ul style="list-style-type: none"> You can set-up the width (five options) of the resonance suppression notch filter in 5 steps. The higher the setting is, the wider the width you can obtain. In normal cases, the default value should be used. 						
1 F	Disturbance torque observer	0 ~ 8 [8]	—	<ul style="list-style-type: none"> You can set-up the time constant (eight options) of the primary delay filter inserted in the Disturbance torque observer. <table border="1" style="margin-left: auto; margin-right: auto;"> <thead> <tr> <th colspan="2">Value of Pr1F</th> </tr> </thead> <tbody> <tr> <td style="text-align: center;">0 ~ 7</td> <td style="text-align: center;">8</td> </tr> <tr> <td>The smaller the setting is, the larger the suppression you can expect. *1</td> <td>Disturbance torque observer disabled.</td> </tr> </tbody> </table>	Value of Pr1F		0 ~ 7	8	The smaller the setting is, the larger the suppression you can expect. *1	Disturbance torque observer disabled.
Value of Pr1F										
0 ~ 7	8									
The smaller the setting is, the larger the suppression you can expect. *1	Disturbance torque observer disabled.									
<p>*1 Note that the running noise of the motor becomes larger, with a smaller value of Pr1F(better suppression of the Disturbance torque). It is recommended that you start from the smaller value of Pr1F to see the actual response and increase the value.</p> <ul style="list-style-type: none"> For the calculation of Disturbance torque in the observer, the inertia ratio (Pr20) is necessary. If the load inertia is known, calculate the inertia ratio and set the value of Pr20 to the inertia ratio calculated. If the load inertia is unknown, perform the auto gain tuning that automatically enters the value of Pr20. 										

<Note>

- For the default values of Pr19, Pr1C and Pr20, see page 44.

Parameters for real time gain tuning

PrNo.	Parameter	Value	Unit	Function													
2 0	Inertia ratio	0 ~ 10000	%	<ul style="list-style-type: none"> You can set-up the ratio of load inertia to the motor's rotor inertia. <div style="border: 1px solid black; padding: 5px; margin: 5px 0;"> $\text{Pr20} = (\text{Load inertia}) / (\text{Rotor inertia}) \times 100\%$ </div> <ul style="list-style-type: none"> The load inertia can be estimated by executing the auto gain tuning, and this result will be reflected in this parameter. <p>If Pr20 (inertia ratio) is set correctly, the unit of the values of Pr11 and Pr19 becomes Hz. If the value of Pr20 is larger than the actual load inertia, the unit of the value of these parameters becomes larger. If the value of Pr20 is smaller than the actual load inertia, the unit of the value of these parameters becomes smaller.</p>													
2 1	Real time auto tuning set-up	0 ~ 3 [0]	—	<ul style="list-style-type: none"> You can define the operating mode of the real time auto tuning. <table border="1" style="width: 100%; border-collapse: collapse; margin: 5px 0;"> <thead> <tr> <th style="width: 10%;">Value</th> <th style="width: 40%;">Real time auto tuning</th> <th style="width: 50%;">Fluctuation of load inertia during operation</th> </tr> </thead> <tbody> <tr> <td style="text-align: center;">0</td> <td style="text-align: center;">Not used</td> <td style="text-align: center;">—</td> </tr> <tr> <td style="text-align: center;">1</td> <td rowspan="3" style="text-align: center;">Used</td> <td style="text-align: center;">Rarely fluctuates</td> </tr> <tr> <td style="text-align: center;">2</td> <td style="text-align: center;">Fluctuates slowly</td> </tr> <tr> <td style="text-align: center;">3</td> <td style="text-align: center;">Fluctuates quickly</td> </tr> </tbody> </table> <ul style="list-style-type: none"> With a larger value of Pr21, a quicker response to the change in load inertia can be obtained, though the operation may become unstable depending on the operating pattern. In normal cases, the value of this parameter should be 1 or 2. 	Value	Real time auto tuning	Fluctuation of load inertia during operation	0	Not used	—	1	Used	Rarely fluctuates	2	Fluctuates slowly	3	Fluctuates quickly
Value	Real time auto tuning	Fluctuation of load inertia during operation															
0	Not used	—															
1	Used	Rarely fluctuates															
2		Fluctuates slowly															
3		Fluctuates quickly															
2 2	Machine stiffness at auto tuning	0 ~ 9 [2]	—	<ul style="list-style-type: none"> You can set-up the machine stiffness (from 10 options) that is used at the real time auto gain tuning. <div style="border: 1px solid black; padding: 10px; margin: 5px 0; text-align: center;"> <p>Low ← Machine stiffness → High</p> <p>Low ← Servo gain → High</p> <table border="1" style="margin: 0 auto; border-collapse: collapse;"> <tr> <td style="padding: 2px 10px;">Pr22</td> <td style="padding: 2px 10px;">0 • 1 • ----- • 8 • 9</td> </tr> </table> <p>Low ← Response → High</p> </div> <ul style="list-style-type: none"> Large impact shock might be given to the machine, when you suddenly set this parameter to a larger value. Start from the smaller value while monitoring the machine movement. 	Pr22	0 • 1 • ----- • 8 • 9											
Pr22	0 • 1 • ----- • 8 • 9																

Details of Parameters

Parameters for Switching to 2nd Gains

PrNo.	Parameter description	Range	Unit	Function																				
3 0	2nd gain action set-up	0 ~ 1 [0]	—	<p>• You can select the switching between PI and P operations, and switching between the 1st and 2nd gains.</p> <table border="1"> <thead> <tr> <th>Value</th> <th>Gain selection and switching</th> </tr> </thead> <tbody> <tr> <td>0</td> <td>Fixed to the 1st gains *1 (switching between PI and P possible)</td> </tr> <tr> <td>1</td> <td>Switching between the 1st and 2nd gains possible *2</td> </tr> </tbody> </table> <p>*1 Switch the PI and P-action with the gain switching input (GAIN: CN I/F Pin 27).</p> <table border="1"> <thead> <tr> <th>GAIN input</th> <th>Operation of the position loop</th> </tr> </thead> <tbody> <tr> <td>COM- disconnected</td> <td>PI operation</td> </tr> <tr> <td>COM- connected</td> <td>P operation</td> </tr> </tbody> </table> <p>*2 See Adjustment for the conditions for switching between the 1st and 2nd gains.</p>	Value	Gain selection and switching	0	Fixed to the 1st gains *1 (switching between PI and P possible)	1	Switching between the 1st and 2nd gains possible *2	GAIN input	Operation of the position loop	COM- disconnected	PI operation	COM- connected	P operation								
Value	Gain selection and switching																							
0	Fixed to the 1st gains *1 (switching between PI and P possible)																							
1	Switching between the 1st and 2nd gains possible *2																							
GAIN input	Operation of the position loop																							
COM- disconnected	PI operation																							
COM- connected	P operation																							
3 1	Position control switching mode	0 ~ 8 [0]	—	<p>AE You can select the conditions for switching between the 1st and 2nd gains at the position control mode.</p> <table border="1"> <thead> <tr> <th>Value</th> <th>Conditions for gain switching</th> </tr> </thead> <tbody> <tr> <td>0</td> <td>Fixed to the 1st gain</td> </tr> <tr> <td>1</td> <td>Fixed to the 2nd gain</td> </tr> <tr> <td>2</td> <td>2nd gain selection with the gain switching input (GAIN) ON/ (Pr30 must be set to 1)</td> </tr> <tr> <td>3</td> <td>2nd gain selection with a larger torque command change</td> </tr> <tr> <td>4</td> <td>Fixed to the 1st gain</td> </tr> <tr> <td>5</td> <td>2nd gain selection with a larger velocity command</td> </tr> <tr> <td>6</td> <td>2nd gain selection with a larger position error</td> </tr> <tr> <td>7</td> <td>2nd gain selection with the position command issued</td> </tr> <tr> <td>8</td> <td>2nd gain selection with no in-position</td> </tr> </tbody> </table>	Value	Conditions for gain switching	0	Fixed to the 1st gain	1	Fixed to the 2nd gain	2	2nd gain selection with the gain switching input (GAIN) ON/ (Pr30 must be set to 1)	3	2nd gain selection with a larger torque command change	4	Fixed to the 1st gain	5	2nd gain selection with a larger velocity command	6	2nd gain selection with a larger position error	7	2nd gain selection with the position command issued	8	2nd gain selection with no in-position
Value	Conditions for gain switching																							
0	Fixed to the 1st gain																							
1	Fixed to the 2nd gain																							
2	2nd gain selection with the gain switching input (GAIN) ON/ (Pr30 must be set to 1)																							
3	2nd gain selection with a larger torque command change																							
4	Fixed to the 1st gain																							
5	2nd gain selection with a larger velocity command																							
6	2nd gain selection with a larger position error																							
7	2nd gain selection with the position command issued																							
8	2nd gain selection with no in-position																							

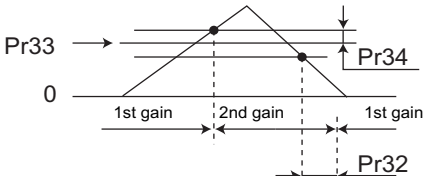
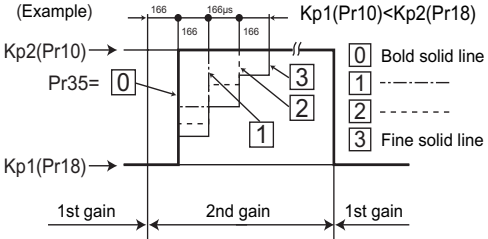
PrNo.	Parameter description	Range	Unit	Function
3 2	Position control switching delay time	0 ~ 10000 [0]	x 166 μs	<ul style="list-style-type: none"> You can set-up the delay time when switching from the 2nd. to the 1st. gain when the actual status shifts out of the preset condition with Pr31.(see page 62)
3 3	Position control switching level	0 ~ 10000 [0]	—	<ul style="list-style-type: none"> This parameter is enabled when Pr31 is set to 3, 5 and 6, and you can define the level of judgement fo switch from the 1st. to the 2nd. gain.
3 4	Position control switching hysteresis	0 ~ 10000 [0]	—	<ul style="list-style-type: none"> You can set-up the width of the hysteresis to be defined at the top and bottom of the level of judgement set with Pr33. The figure below shows the definitions of Pr32 (delay time), Pr33 (switching level) and Pr34 (hysteresis).  <p><Notes> The settings of Pr33 (level) and Pr34 (hysteresis) are enabled as absolute values.</p>
3 5	Position loop gain switching time	0 ~ 10000 [0]	(Value + 1) x 166 μs	<ul style="list-style-type: none"> You can set-up a phased switching time of the gain applied to the position loop alone, while the 2nd. gain switching function is enabled. <p>(Example) $Kp1(Pr10) < Kp2(Pr18)$</p>  <p> 0 Bold solid line 1 Dotted line 2 Dashed line 3 Fine solid line </p> <ul style="list-style-type: none"> Use this parameter only for switching from a smaller position loop gain to a larger position loop gain (from Kp1 to Kp2) (in order to reduce the impact forces caused by a large change in gain). Set the smaller value than the difference between KP2 and KP1.

Details of Parameters

PrNo.	Parameter description	Range	Unit	Function	
3 6	Velocity control switching mode	0 ~ 5	—	<ul style="list-style-type: none"> You can select the conditions for switching between the 1st and 2nd gains at position control. Pr36 is same as Pr31(Position control switching mode) except for the position control portion. 	
		[0]			
		Value	Gain switching		
		0	Fixed to the 1nd gain		
		1	Fixed to the 2nd gain		
		2	2nd gain selection with the gain switching input (GAIN) ON (Pr30 must be set to 1)		
		3	2nd gain selection with a large torque command change		
		4	2nd gain selection with a large velocity command change (acceleration)		
5	2nd gain selection with a large velocity command				
3 7	Velocity control switching delay time	0~100000 [0]	x 166 μs	<ul style="list-style-type: none"> Same as Pr32 (switching delay time), Pr33 (switching level) and Pr34 (switching hysteresis) for position control. 	
3 8	Velocity control switching level	0~100000 [0]	—		
3 9	Velocity control switching hysteresis	0~100000 [0]	—		
3 A	Torque control switching mode	0 ~ 3	—	<ul style="list-style-type: none"> You can select the conditions for switching between the 1st and 2nd gains at torque control. Pr3A is same as Pr31 except position control and velocity control portion. 	
		[0]			
		Value	Gain switching		
		0	Fixed to the 1nd gain		
		1	Fixed to the 2nd gain		
2	2nd gain selection with the gain switching input (GAIN) ON (Pr30 must be set to 1)				
3	2nd gain selection with a large torque command change				
3 B	Torque control switching delay time	0~100000 [0]	x 166 μs	<ul style="list-style-type: none"> Same as Pr32 (switching delay time), Pr33 (switching level) and Pr34 (switching hysteresis) for position control. 	
3 C	Torque control switching level	0~100000 [0]	—		
3 D	Torque control switching hysteresis	0~100000 [0]	—		

Parameters for Position Control

PrNo.	Parameter description	Range	Function																				
4 0	Command pulse multiplier set-up	1 ~ 4 [4]	<p>You can set-up the multiplication when [quadrature pulse input] is selected with Pr42(Command pulse input mode set-up).</p> <table border="1" style="width: 100%; margin-top: 10px;"> <thead> <tr> <th style="width: 20%;">Value</th> <th>Multiplication at quadrature pulse input</th> </tr> </thead> <tbody> <tr> <td style="text-align: center;">1</td> <td style="text-align: center;">x 1</td> </tr> <tr> <td style="text-align: center;">2</td> <td style="text-align: center;">x 2</td> </tr> <tr> <td style="text-align: center;">3 or 4</td> <td style="text-align: center;">x 4</td> </tr> </tbody> </table>	Value	Multiplication at quadrature pulse input	1	x 1	2	x 2	3 or 4	x 4												
Value	Multiplication at quadrature pulse input																						
1	x 1																						
2	x 2																						
3 or 4	x 4																						
4 1	Command pulse logic inversion	0 ~ 3 [0]	<p>You can individually set-up the logic of 2-series of pulse command inputs (PULSE and SIGN).</p> <table border="1" style="width: 100%; margin-top: 10px;"> <thead> <tr> <th style="width: 15%;">Value</th> <th style="width: 35%;">Logic of PULSE signal</th> <th style="width: 35%;">Logic of SIGN signal</th> </tr> </thead> <tbody> <tr> <td style="text-align: center;">0</td> <td style="text-align: center;">Non-inversion</td> <td style="text-align: center;">Non-inversion</td> </tr> <tr> <td style="text-align: center;">1</td> <td style="text-align: center;">Inversion</td> <td style="text-align: center;">Non-inversion</td> </tr> <tr> <td style="text-align: center;">2</td> <td style="text-align: center;">Non-inversion</td> <td style="text-align: center;">Inversion</td> </tr> <tr> <td style="text-align: center;">3</td> <td style="text-align: center;">Inversion</td> <td style="text-align: center;">Inversion</td> </tr> </tbody> </table>	Value	Logic of PULSE signal	Logic of SIGN signal	0	Non-inversion	Non-inversion	1	Inversion	Non-inversion	2	Non-inversion	Inversion	3	Inversion	Inversion					
Value	Logic of PULSE signal	Logic of SIGN signal																					
0	Non-inversion	Non-inversion																					
1	Inversion	Non-inversion																					
2	Non-inversion	Inversion																					
3	Inversion	Inversion																					
4 2	Command pulse input mode set-up	0 ~ 3 [1]	<p>You can set-up the type of command pulse to be given to the driver from the controller. There are three types of command pulse as shown in the table below. Select an appropriate type according to the controller.</p> <table border="1" style="width: 100%; margin-top: 10px;"> <thead> <tr> <th style="width: 10%;">Value</th> <th style="width: 15%;">Type of command pulse</th> <th style="width: 10%;">Signal</th> <th style="width: 20%;">CCW command</th> <th style="width: 20%;">CW command</th> </tr> </thead> <tbody> <tr> <td style="text-align: center;">0 or 2</td> <td>Quadrature pulse command mode</td> <td>PULS SIGN</td> <td> <p style="font-size: small;">B-phase advances A-phase by 90 degrees</p> </td> <td> <p style="font-size: small;">B-phase delays from A-phase by 90 degrees</p> </td> </tr> <tr> <td style="text-align: center;">1</td> <td>CW/CCW pulse command mode</td> <td>PULS SIGN</td> <td> <p style="font-size: small;">t2</p> </td> <td></td> </tr> <tr> <td style="text-align: center;">3</td> <td>Pulse/Sign command mode</td> <td>PULS SIGN</td> <td> <p style="font-size: small;">t4 t5 "H"</p> </td> <td> <p style="font-size: small;">t4 t5 "L"</p> </td> </tr> </tbody> </table>	Value	Type of command pulse	Signal	CCW command	CW command	0 or 2	Quadrature pulse command mode	PULS SIGN	<p style="font-size: small;">B-phase advances A-phase by 90 degrees</p>	<p style="font-size: small;">B-phase delays from A-phase by 90 degrees</p>	1	CW/CCW pulse command mode	PULS SIGN	<p style="font-size: small;">t2</p>		3	Pulse/Sign command mode	PULS SIGN	<p style="font-size: small;">t4 t5 "H"</p>	<p style="font-size: small;">t4 t5 "L"</p>
Value	Type of command pulse	Signal	CCW command	CW command																			
0 or 2	Quadrature pulse command mode	PULS SIGN	<p style="font-size: small;">B-phase advances A-phase by 90 degrees</p>	<p style="font-size: small;">B-phase delays from A-phase by 90 degrees</p>																			
1	CW/CCW pulse command mode	PULS SIGN	<p style="font-size: small;">t2</p>																				
3	Pulse/Sign command mode	PULS SIGN	<p style="font-size: small;">t4 t5 "H"</p>	<p style="font-size: small;">t4 t5 "L"</p>																			

Details of Parameters

PrNo.	Parameter description	Range	Function																														
4 2 (continued)	<p>Maximum permissible frequency and minimum required time width of command pulse inputs</p> <table border="1"> <thead> <tr> <th rowspan="2">I/F for inputting PULSE/SIGN signals</th> <th rowspan="2">Maximum permissible frequency</th> <th colspan="6">Minimum required time width [μs]</th> </tr> <tr> <th>t₁</th> <th>t₂</th> <th>t₃</th> <th>t₄</th> <th>t₅</th> <th>t₆</th> </tr> </thead> <tbody> <tr> <td>Interface for line drivers</td> <td>500kps</td> <td>2</td> <td>1</td> <td>1</td> <td>1</td> <td>1</td> <td>1</td> </tr> <tr> <td>Interface for open collectors</td> <td>200kpps</td> <td>5</td> <td>2.5</td> <td>2.5</td> <td>2.5</td> <td>2.5</td> <td>2.5</td> </tr> </tbody> </table> <p>Make both of the rising and tailing time 0.1 μs or shorter.</p>			I/F for inputting PULSE/SIGN signals	Maximum permissible frequency	Minimum required time width [μ s]						t ₁	t ₂	t ₃	t ₄	t ₅	t ₆	Interface for line drivers	500kps	2	1	1	1	1	1	Interface for open collectors	200kpps	5	2.5	2.5	2.5	2.5	2.5
I/F for inputting PULSE/SIGN signals	Maximum permissible frequency	Minimum required time width [μ s]																															
		t ₁	t ₂	t ₃	t ₄	t ₅	t ₆																										
Interface for line drivers	500kps	2	1	1	1	1	1																										
Interface for open collectors	200kpps	5	2.5	2.5	2.5	2.5	2.5																										
4 3	Command pulse inhibit input invalidation	0 ~ 1 [1]	<p>You can select enabled or disabled of the command pulse inhibit input (INH: CN I/F Pin 33).</p> <table border="1"> <thead> <tr> <th>Value</th> <th>INH input</th> </tr> </thead> <tbody> <tr> <td>0</td> <td>enabled</td> </tr> <tr> <td>1</td> <td>disabled</td> </tr> </tbody> </table> <p>Command pulse input is disabled by opening the connection between INH input and COM-. If you do not use INH inputs, set Pr43 to 1. With this setting, you do not have to externally connect between INH (CN I/F Pin 33) and COM- (Pin 41).</p>	Value	INH input	0	enabled	1	disabled																								
Value	INH input																																
0	enabled																																
1	disabled																																
4 4	Output pulses per single turn	1 ~ 16384 [2500]	<p>You can set-up encoder pulse counts per single turn, which is to be fed-out to the controller. Setting in scalar. Set the required pulse counts per single turn in [Pulse/rev] unit directly. Note that the set-up of the larger counts than the encoder pulses is disabled.</p>																														

PrNo.	Parameter description	Range	Function															
4 5	Pulse output logic inversion	0 ~ 1 [0]	When the motor runs CW, the B-phase pulse advances the A-phase pulse (when the motor runs CCW, the B-phase pulse delays from the A-phase pulse). You can invert the the phase relation between A and B phases by inverting the logic of the B-phase pulse with this parameter.															
<table border="1"> <thead> <tr> <th>Value</th> <th></th> <th>CCW run</th> <th>CW run</th> </tr> </thead> <tbody> <tr> <td rowspan="2">0</td> <td>A-phase (OA),</td> <td></td> <td></td> </tr> <tr> <td>B-phase (OB), non-inversion</td> <td></td> <td></td> </tr> <tr> <td rowspan="2">1</td> <td>B-phase (OB), inversion</td> <td></td> <td></td> </tr> </tbody> </table>				Value		CCW run	CW run	0	A-phase (OA),			B-phase (OB), non-inversion			1	B-phase (OB), inversion		
Value		CCW run	CW run															
0	A-phase (OA),																	
	B-phase (OB), non-inversion																	
1	B-phase (OB), inversion																	
	Parameters for Pulse Command Scaler (Pr46 through Pr4B)																	
4 6	Numerator of 1st command pulse ratio	1 ~ 10000	Pulse command scaling function (electronic gear) • Purpose 1) You can set-up any motor speed or work travel amount per input command pulse(unit). 2) You can increase the nominal command pulse frequency with scaling, when your required speed can't be obtained due to the capacity of the pulse generator of the controller(maximum available frequency). • Block diagram of the scaling function															
4 7	Numerator of 2st command pulse ratio	1 ~ 10000																
4 8	Numerator of 3st command pulse ratio	1 ~ 10000																
4 9	Numerator of 4st command pulse ratio	1 ~ 10000																
4 A	Multiplier of numerator of command pulse ratio	0 ~ 17																
4 B	Denominator of command pulse ratio	1 ~ 10000																
			• The calculated numerator is max. 2621440. Set-up of larger value than this is disabled, and automatically substituted by 2621440.															

<Note>

For the default values of Pr46 through Pr4B, see page 46.

Details of Parameters

PrNo.	Parameter description	Range	Function				
46 ~ 4B (continued)			<p>You can select the numerator of the command scalar.</p> <p>*1 Select the 1st. or 2nd. numerator with scalar input switching (DIV: CN I/F Pin 28) .</p> <table border="1"> <tr> <td>DIV off</td> <td>1st numerator (Pr46) selection</td> </tr> <tr> <td>DIV on</td> <td>2st numerator (Pr47) selection</td> </tr> </table> <p>*2 Use the 3rd and 4th command scalars only for special operations such as "fill-close" operations. For details, see FullClose Specifications.</p> <p><Example></p> <ul style="list-style-type: none"> Basic relation is defined so as the motor runs one revolution with the command input of encoder resolution(f), when the scale ratio is 1. Therefore, when the encoder resolution is 10000 P/r, it is necessary to enter f=5000 pulses in case of scale ratio of 2, and f=40000 pulse in case of scale ratio of 1/4 to turn the motor one revolution. Set-up the Pr46, Pr4A and Pr4B so that the post-scaling internal command (F) equals the resolution (10000 or 217) of the encoder. <div style="border: 1px solid black; padding: 5px; margin-top: 10px;"> $F = f \times (\text{Pr46} \times 2^{\text{Pr4A}}) / \text{Pr4B} = 10000 \text{ or } 2^{17}$ <p>F: Internal command pulse counts required for motor one revolution f: Command pulse counts required for motor one revolution</p> </div>	DIV off	1st numerator (Pr46) selection	DIV on	2st numerator (Pr47) selection
DIV off	1st numerator (Pr46) selection						
DIV on	2st numerator (Pr47) selection						
Resolution of encoder		2 ¹⁷ (131072)	10000(2500P/r x 4)				
Example 1: Command input (f) is 5000 pulses per one revolution		$\frac{\text{Pr 46} \boxed{1} \times 2}{\text{Pr 4B} \boxed{5000}}$	$\frac{\text{Pr 46} \boxed{10000} \times 2}{\text{Pr 4B} \boxed{5000}}$				
Example 1: Command input (f) is 4000 pulses per one revolution		$\frac{\text{Pr 46} \boxed{1} \times 2}{\text{Pr 4B} \boxed{10000}}$	$\frac{\text{Pr 46} \boxed{2500} \times 2}{\text{Pr 4B} \boxed{10000}}$				

PrNo.	Parameter description	Range	Function										
4 C	Smoothing filter set-up	0 ~ 7 [1]	<p>This filter is a primary delay filter that is inserted after the scaling function in the command pulse input portion.</p> <div style="border: 1px solid black; padding: 5px; margin: 5px 0;"> <p>Purpose of this filter</p> <ul style="list-style-type: none"> • Reduce the stepwise motion of the motor that may appear when the command input is rough. • The command input may become rough when: <ol style="list-style-type: none"> 1) The scale ratio is large (10 times or greater) 2) The command frequency is low. </div> <p>• You can set-up the time constant of the smoothing filter in 8 steps with Pr4C.</p> <table border="1" style="width: 100%; border-collapse: collapse; text-align: center;"> <thead> <tr> <th>Value</th> <th>Time constant</th> </tr> </thead> <tbody> <tr> <td>0</td> <td>No filtering function</td> </tr> <tr> <td>1</td> <td>↓</td> </tr> <tr> <td>~</td> <td>Large time constant</td> </tr> <tr> <td>7</td> <td>↓</td> </tr> </tbody> </table>	Value	Time constant	0	No filtering function	1	↓	~	Large time constant	7	↓
Value	Time constant												
0	No filtering function												
1	↓												
~	Large time constant												
7	↓												
4 D	Counter clear input	0 ~ 1 [0]	<p>You can set-up the conditions for clearing the position error counter, i.e. for issuing the counter clear signal (CL: CN I/F Pin 30).</p> <table border="1" style="width: 100%; border-collapse: collapse; text-align: center;"> <thead> <tr> <th>Value</th> <th>Conditions</th> </tr> </thead> <tbody> <tr> <td>0</td> <td>Cleared with level (*1)</td> </tr> <tr> <td>1</td> <td>Cleared with edge (rising part)</td> </tr> </tbody> </table> <p>*1 : Minimum time width of the CL signal</p> <div style="text-align: center; margin-top: 10px;"> <p>CL (pin 30)</p> <p style="margin-left: 150px;">min. 100É s</p> </div>	Value	Conditions	0	Cleared with level (*1)	1	Cleared with edge (rising part)				
Value	Conditions												
0	Cleared with level (*1)												
1	Cleared with edge (rising part)												

Details of Parameters

Parameters for Velocity Control

PrNo.	Parameter description	Range	Function						
5 0	Velocity command input gain	10 ~ 2000 [500]	<p>You can set-up the relationship between the motor speed and the voltage applied to the velocity command input (SPR: CN I/F Pin 14).</p> <div style="border: 1px solid black; padding: 10px; margin-top: 10px;"> <ul style="list-style-type: none"> • Pr50 defines the gradient "rpm/command voltage". • The default of Pr50 is 500 [(r/min)/V], e.g. 6V with 3000 r/min. <div style="text-align: center; margin: 10px 0;"> </div> <p><Notes></p> <ol style="list-style-type: none"> 1. Don't apply more than 10V to the velocity command input (SPR). 2. If the position loop is composed externally, the set-up value of Pr50 affects the overall position gain. Higher set-up of Pr50 could cause oscillation. </div>						
5 1	Velocity command input logic inversion	0 ~ 1 [1]	<p>You can invert the polarity of the velocity command input (SPR). Use this parameter in such a case as you want to change the motor rotating direction without changing the polarity of the command signals from the controller.</p> <table border="1" style="margin: 10px auto;"> <thead> <tr> <th>Value</th> <th>Rotating direction</th> </tr> </thead> <tbody> <tr> <td>0</td> <td>CCW with (+) command (viewed from the shaft end)</td> </tr> <tr> <td>1</td> <td>CW with (+) command (viewed from the shaft end)</td> </tr> </tbody> </table> <p><Notes></p> <p>The default of this parameter is 1, i.e. CW rotation with (+) command. Note that the conventional versions of MINAS series drivers have the same default setting.</p> <div style="border: 1px solid black; padding: 10px; margin-top: 10px;"> <p><Notes></p> <p>When the driver is used at velocity control mode, in combination with the external positioning unit, pay extra attention to the case when the polarity of this parameter does not match to that of the velocity signal from the positioning unit. This could cause the motor malfunction.</p> </div>	Value	Rotating direction	0	CCW with (+) command (viewed from the shaft end)	1	CW with (+) command (viewed from the shaft end)
Value	Rotating direction								
0	CCW with (+) command (viewed from the shaft end)								
1	CW with (+) command (viewed from the shaft end)								

PrNo.	Parameter description	Range	Function				
5 2	Velocity command offset	-2047 ~ 2047 [0]	<ul style="list-style-type: none"> You can adjust the offset of the external analogue velocity command system including that the controller. The offset is about 0.3mV per unit of this parameter. There are two ways for adjusting the offset : (1) manual adjustment and (2) automatic adjustment. <div style="border: 1px solid black; padding: 10px; margin-top: 10px;"> <p>1) Manual adjustment</p> <ul style="list-style-type: none"> when executing the adjustment with the driver alone., Set-up the value with this parameter so that the motor may not run, after entering 0V exactly to the velocity command input (SPR). when the position loop is composed at the controller side, set-up the value with this parameter so that the error pulse may become to 0 at Servo-lock status. <p>2) Automatic adjustment</p> <ul style="list-style-type: none"> For detailed procedure, see Details of Operation in Appendix. The results of the automatic adjustment will be automatically entered as the value of this parameter. </div>				
5 3	1st internal speed	-10000 ~ 10000 [0]	<p>You can set-up the internal command velocity of 1st to 4th speed to Pr53 to 56 respectively in [r/min] unit, when the internal velocity set-up is enabled with the parameter Pr05 (Switching of internal and external velocity set-up).</p> <p><Note> The polarity (+/- sign) of the set values shows the polarity of internal command velocities.</p>				
5 4	2nd internal speed	-10000 ~ 10000 [0]	<table border="1" style="width: 100%; text-align: center;"> <tr> <td style="width: 30px;">+</td> <td>CCW run</td> </tr> <tr> <td>-</td> <td>CW run</td> </tr> </table>	+	CCW run	-	CW run
+	CCW run						
-	CW run						
5 5	3rd internal speed	-10000 ~ 10000 [0]	Pr56 defines the velocity limit at the torque control mode.				
5 6	4th internal speed	-10000 ~ 10000 [0]					
5 7	JOD speed set-up	0 ~ 500 [300]	<p>You can set-up the JOG speed in [r/min] at JOG trial run mode.</p> <p>For details of JOG functions, see Trail run.</p>				

Details of Parameters

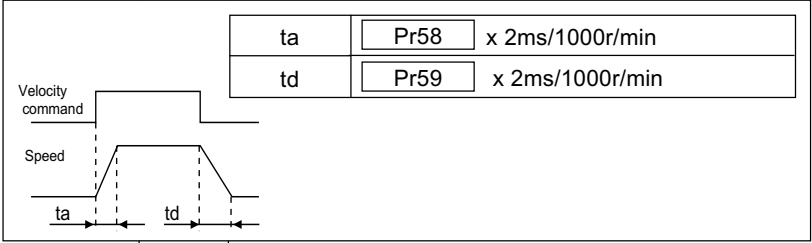
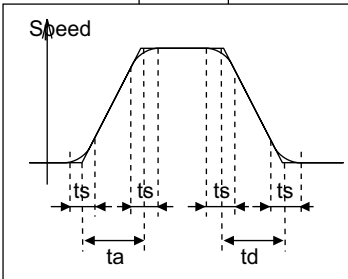
PrNo.	Parameter description	Range	Function						
5 8	Acceleration time set-up	0 ~ 5000 [0]	You can control the speed while applying the acceleration/ deceleration to the velocity commands in the driver, at velocity control mode.						
5 9	Deceleration time set-up	0~ 5000 [0]	You can obtain soft-start/soft-down action of the motor when the phased velocity command is entered, or when the internal velocity set-up is selected.						
 <table border="1" data-bbox="408 427 974 507"> <tr> <td>ta</td> <td>Pr58</td> <td>x 2ms/1000r/min</td> </tr> <tr> <td>td</td> <td>Pr59</td> <td>x 2ms/1000r/min</td> </tr> </table>			ta	Pr58	x 2ms/1000r/min	td	Pr59	x 2ms/1000r/min	<p><Notes> Don't use these parameters if the driver is used in combination with the external position loop. (Both Pr58 and Pr59 should be set to 0).</p>
ta	Pr58	x 2ms/1000r/min							
td	Pr59	x 2ms/1000r/min							
5 A	S-shaped accel/decel time set-up	0 ~ 500 [0]	You can add a quasi S-shaped acceleration/deceleration to the velocity command, so that smooth operation can be obtained in such a case as a large impact shock will be given at starting or stopping with a linear acceleration/deceleration.						
 <ol data-bbox="565 925 974 1053" style="list-style-type: none"> 1. Set the basic acceleration/deceleration time for the linear regions with Pr58 and Pr59. 2. Set the time of the S-shaped portion, centering the acceleration/deceleration changing regions with Pr5A. Unit in 2 ms. <p> $ta \hat{=} Pr58$ $td \hat{=} Pr59$ $ts \hat{=} Pr5A$ </p>									
5 C	Torque command input gain	10 ~ 100 [30]	You can set-up the relationship between the motor torque and the voltage applied to the torque command input (TRQR: CN I/F pin 14).						

Parameters for Torque Control

PrNo.	Parameter description	Range	Function						
5 C (continued)	<ul style="list-style-type: none"> The unit of the set-up is [0.1V/100%]. Enter the required voltage for producing the rated torque. The default value of 30 corresponds to 3V/100%. 								
5 D	Torque command input inversion	0 ~ 1 [0]	<p>You can invert the polarity of the torque command input signal (TRQR: CN I/F Pin 14) when Pr02 = 5.</p> <p>When the driver has been configured for torque control, the torque command signal input uses CN I/F Pin 16.</p> <table border="1"> <thead> <tr> <th>Value</th> <th>Direction of motor torque</th> </tr> </thead> <tbody> <tr> <td>0</td> <td>CCW torque with (+) commands</td> </tr> <tr> <td>1</td> <td>CW torque with (+) commands</td> </tr> </tbody> </table>	Value	Direction of motor torque	0	CCW torque with (+) commands	1	CW torque with (+) commands
Value	Direction of motor torque								
0	CCW torque with (+) commands								
1	CW torque with (+) commands								
5 E	Torque limit set-up	0 ~ 500 [300]	<p>You can limit the max. motor torque with this parameter.</p> <p>In normal specifications, the driver can produce 300 % of the \hat{A} rated torque for a short duration(peak-torque). Use this limiting \hat{A} function when 300% torque may cause the trouble to the \hat{A} machine.</p>						
	<ul style="list-style-type: none"> Set-up the value in % against the rated torque. The right figure shows an example that the maximum torque is limited to 150% of the rated torque. This parameter limits the maximum torque in both CW and CCW directions. 								
	<Notes>		<p>You can't set-up a greater value with this parameter than default value (300%), which is defined by the system parameter (Max. torque output).</p>						

Details of Parameters

Parameters for various sequences

PrNo.	Parameter description	Range	Function
6 0	In-position range	0 ~ 32767	<ul style="list-style-type: none"> You can set-up the output timing of the in-position signal (COIN: CN I/F Pin 39), completing the travel of the motor (work), after the command pulse entry. The in-position (positioning complete) signal (COIN) will be fed-out when the position error counter pulsed fall within a preset range
<p>• The unit of position error pulses is the "resolution" of the encoder. It differs depending on the type of encoder.</p> <p>1) 17-bit encoder: 217 = 131072</p> <p>2) 2500 P/rev encoder: 4 x 2500</p> <p><Notes></p> <ol style="list-style-type: none"> If you set-up too small value to Pr60, time to feed-out COIN signal gets longer, or causes a chattering. The value of this parameter does not affect the accuracy in positioning. 			
6 1	Zero speed	0 ~ 10000 [50]	<ul style="list-style-type: none"> You can set-up the output timing of the zero speed detection signal (ZSP: CN I/F pin 12). Unit in [r/min]. The ZSP signal will be fed-out when the motor speed becomes lower than this setting.
<p>Pr61 affects both CW and CCW directions regardless of the actual rotating direction.</p>			

<Note>

For the default values of Pr60 and Pr63, see page 46.

PrNo.	Parameter description	Range	Function						
6 2	At-speed	0 ~ 10000 [1000]	<ul style="list-style-type: none"> You can set-up the output timing of the at-speed signal (COIN : CN I/F pin 39) at velocity and torque control mode. Unit in [r/min]. The at-speed (COIN) signal will be fed-out when the motor speed exceeds the preset value by this parameter. 						
<p>Pr62 affects both CW and CCW rotation regardless of the actual rotating direction.</p>									
6 3	Position error set-up	0 ~ 32767	<ul style="list-style-type: none"> You can set-up the detection level for the position error limit at [Position error limit protection], with error counter pulses. 						
<p>• Calculate the value of this parameter using the following formula.</p> <div style="border: 1px solid black; padding: 5px; width: fit-content; margin: 10px auto;"> $\text{Parameter value} = [\text{Position error limit level (pulses)}] / 256$ </div> <p><Note> If you set the position gain to low value, and set this Pr63 value too small, the position error limit protection could be activated, even though no error is to be found.</p>									
6 4	Position error invalidation	0 ~ 1 [0]	You can disable the position error limit protection.						
		<table border="1" style="width: 100%;"> <thead> <tr> <th>Value</th> <th>Position error limit protection</th> </tr> </thead> <tbody> <tr> <td>0</td> <td>Enabled</td> </tr> <tr> <td>1</td> <td>Disabled. The motor continues to run, even though the pulse counts exceeds the level set by Pr63, judging that no error is found.</td> </tr> </tbody> </table>		Value	Position error limit protection	0	Enabled	1	Disabled. The motor continues to run, even though the pulse counts exceeds the level set by Pr63, judging that no error is found.
Value	Position error limit protection								
0	Enabled								
1	Disabled. The motor continues to run, even though the pulse counts exceeds the level set by Pr63, judging that no error is found.								

Details of Parameters

PrNo.	Parameter description	Range	Function			
6 5	UVtrip selection at main power-off	0 ~ 1 [1]	You can select whether or not to activate the under-voltage trip in case the main power is shut-off.			
			Value	Under-voltage protective function		
			0	If the main power is lost during Servo-ON, Servo-OFF get active (the motor does not trip). After this, when the main power is on, Servo-ON will be made active again.		
			1	If the main power is lost during Servo-ON, the under-voltage protective function (Err-13) is activated, and the motor trips.		
			See "Timing chart for the mains and control power shut off" in Appendix.			
6 6	DB inhibition at overtravel limit	0 ~ 1 [0]	You can set-up the conditions for decelerating the motor after the over-travel limit input (CCWL: CNI/ F Pin 9 or CWL : CN I/F Pin 8) is made active.			
			Value	Motor operation from deceleration to and after stop		
			0	The dynamic brake (DB) is activated, and the motor is stopped. After stop, the dynamic brake is released.		
			1	Without dynamic brake the motor stops after coasting. After stop, the motor remains free.		
6 7	Sequence at main power-off	0 ~ 7 [0]	You can set-up the conditions of the following operations after main power off. 1) Decelerating and halting the motor 2) Clearing the position error counter			
			Value	Operating conditions		Content of the position error counter
				During deceleration	After stop	
			0	DB	DB	Cleared
			1	Free run (coasting)	DB	↑
			2	DB	Free (DB not engaged)	↑
			3	Free run (coasting)	Free (DB not engaged)	↑
			4	DB	DB	Held
			5	Free run (coasting)	DB	↑
			6	DB	Free (DB not engaged)	↑
			7	Free run (coasting)	Free (DB not engaged)	↑
			(DB: Dynamic brake engaged)			

PrNo.	Parameter description	Range	Function																						
6 8	Sequence at alarm	0 ~ 3 [0]	Defines the conditions for decelerating the motor and keeping the motor stopped after one of the driver's protective functions (alarms) is activated.																						
			<table border="1"> <thead> <tr> <th rowspan="2">Value</th> <th colspan="2">Operating conditions</th> <th rowspan="2">Content of the position error counter</th> </tr> <tr> <th>During deceleration</th> <th>After stop</th> </tr> </thead> <tbody> <tr> <td>0</td> <td>DB</td> <td>DB</td> <td>Cleared</td> </tr> <tr> <td>1</td> <td>Free run (coasting)</td> <td>DB</td> <td>↑</td> </tr> <tr> <td>2</td> <td>DB</td> <td>Free (DB not engaged)</td> <td>↑</td> </tr> <tr> <td>3</td> <td>Free run (coasting)</td> <td>Free (DB not engaged)</td> <td>↑</td> </tr> </tbody> </table>	Value	Operating conditions		Content of the position error counter	During deceleration	After stop	0	DB	DB	Cleared	1	Free run (coasting)	DB	↑	2	DB	Free (DB not engaged)	↑	3	Free run (coasting)	Free (DB not engaged)	↑
			Value		Operating conditions			Content of the position error counter																	
				During deceleration	After stop																				
			0	DB	DB	Cleared																			
			1	Free run (coasting)	DB	↑																			
2	DB	Free (DB not engaged)	↑																						
3	Free run (coasting)	Free (DB not engaged)	↑																						
(DB : Dynamic brake engaged)																									
See also "Timing chart for alarms" in Appendix.																									
6 9	Sequence at servo-off	0 ~ 7 [0]	Defines the following processes after Servo-OFF (SER-ON signal: CN I/F Pin 29). 1) Operating conditions during deceleration and after stop 2) Process for clearing the position error counter																						
			The functions of this parameter and the meanings of parameter values are the same as those of Pr67.																						
			See also "Timing chart for Servo-ON/OFF during the halt of motor" in Appendix.																						
6 A	Mechanical Brake action set-up at motor standstill	0 ~ 100 [0]	Defines the duration from OFF of the brake release signal (BRK-OFF) (i.e. brake engaged) to the shutdown of motor current (servo free) in transition to Servo-OFF during the halt of the motor.																						
			<ul style="list-style-type: none"> The value of this parameter should not be less than the value of t_b (delay of braking) in order to avoid the minute movement or fall of the motor (work). $Pr6A = (Entry) \times 2 \text{ ms}$ 																						
			<p>The timing chart illustrates the sequence of events during a servo-off transition. It shows four signals: SRV-ON, BRK-OFF, Actual braking, and Motor current. SRV-ON transitions from 'On' to 'Off'. BRK-OFF transitions from 'Brake released' to 'Brake engaged', with a delay t_b. Actual braking transitions from 'Brake released' to 'Brake engaged', with a delay $Pr6A$. Motor current transitions from 'Energized' to 'Free (not energized)', with a delay $Pr6A$.</p>																						
See also "Timing chart for Servo-ON/OFF during the halt of motor" in Appendix.																									

Details of Parameters

PrNo.	Parameter description	Range	Function												
6 B	Mechanical brake action set-up at motor in motion	0 ~ 100 [0]	<p>Defines the duration from OFF of the brake release signal (BRK-OFF) (i.e. brake engaged) to the shutdown of motor current (servo free) in transition to Servo-OFF during the motor in motion, not during the halt as handled by Pr6A.</p> <div style="border: 1px solid black; padding: 5px;"> <ul style="list-style-type: none"> This parameter is necessary for avoiding the degradation of the brake due to the rotation of the motor. The value of T_b is the value of Pr6B or the time needed for decreasing the motor revolution to about 30 rpm, whichever is smaller. Pr6B = (Entry) x 2 ms </div> <p>See also "Timing chart for Serve-ON/OFF during the operation of the motor" in Appendix.</p>												
6 C	External regenerative discharge resistor selection	0 ~ 2 [0]	<p>Defines whether the internal regenerative discharge resistor is used, or an external regenerative discharge resistor is installed (between P and B2 terminals on the terminal block) with the internal resistor disconnected.</p> <table border="1" style="width: 100%; border-collapse: collapse;"> <thead> <tr> <th>Value</th> <th>Regenerative discharge resistor</th> <th>Over-regenerative power protection</th> </tr> </thead> <tbody> <tr> <td>0</td> <td>Internal resistor</td> <td>The protection operates for the internal resistor.</td> </tr> <tr> <td>1</td> <td>External resistor</td> <td>The protection operates for the external resistor whose operating limit is 10% of the duty.</td> </tr> <tr> <td>2</td> <td>External resistor</td> <td>No protection</td> </tr> </tbody> </table>	Value	Regenerative discharge resistor	Over-regenerative power protection	0	Internal resistor	The protection operates for the internal resistor.	1	External resistor	The protection operates for the external resistor whose operating limit is 10% of the duty.	2	External resistor	No protection
Value	Regenerative discharge resistor	Over-regenerative power protection													
0	Internal resistor	The protection operates for the internal resistor.													
1	External resistor	The protection operates for the external resistor whose operating limit is 10% of the duty.													
2	External resistor	No protection													

Details of Operation (Monitor Mode)

Motor Mode

Operation

- 1) Turn on the mains power (driver).
- 2) Open the Monitor mode
(see Parameter Setting and MODE's Structure).
- 3) Select a mode that you want to view.

→ `r -`

Motor speed
(initial display)

→ `dP - □□□`

Select this display.

Mode selection

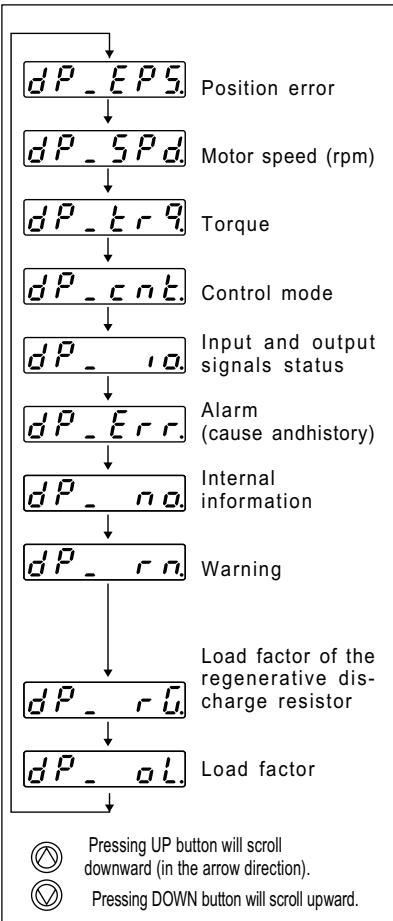

Monitoring/Execution

Display (example)	Meaning
<code>P 3</code>	Position error corresponding to three pulses
<code>r 1000</code>	1000 r/min.
<code>t 100.0</code>	Torque output of 100%
<code>Poscnt</code>	Position control mode
<code>in-0.A</code>	No.0 active
<code>Err. - -</code>	Currently no errors
<code>A. -0.03</code>	Internal information
<code>rn -A-</code>	Overload warning occurred, no battery or no over-regenerative warning occurred
<code>rD 30</code>	30% of the acceptable regenerative discharge
<code>oL 28</code>	Load factor of 28%

Note) With power on, the indication starts with the indication items marked with *.

Details of Operation (Monitor Mode)

Details of Monitor Mode

Indication of position error, motor speed and torque



Data



.....Position error

Display the reading (pulse count) of the position error counter with an indication of polarity (unit: P).

(+): Error in CCW direction

(-): Error in CW direction



.....Motor speed

Display the motor speed (rpm) with an indication of polarity (unit: r/min.).

(+): Revolution in CCW direction

(-): Revolution in CW direction



.....Torque output

Display the generated torque with an indication of polarity (unit: %).

(+): Torque in CCW direction

(-): Torque in CW direction

<Notes>

(+) symbol is not displayed.

Display of Control Mode

Display the current control mode.

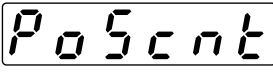

Control mode

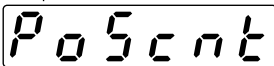

.....Position control mode



.....Speed control mode

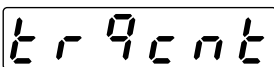

.....Torque control mode

Display of I/O signals status

Display the status of control (input) and output signals via the CN I/F connectors. Use this information for checking the wiring connections.

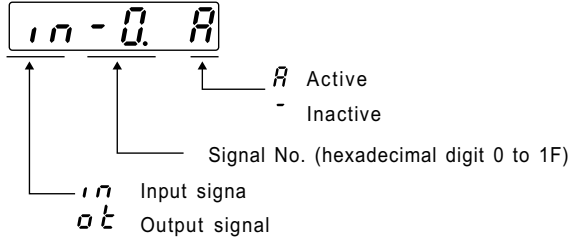

- ⊙ Pressing LEFT button will move the decimal point in blinking.

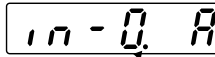

(Decimal point placed on the right side: Signal selection mode)

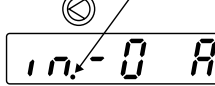

(Decimal point placed on the left side: Input/output selection mode)

1) Input/output selection mode

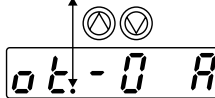
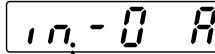

2) Signal selection mode

- ⊙ Pressing UP button will scroll downward (in the arrow direction).

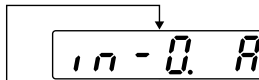

The lowest No. of input signal



The highest No. of input signal

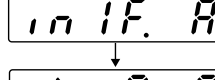

The lowest No. of output signal

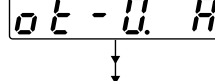

The highest No. of output signal

Details of Operation (Monitor Mode)

Signal Numbers and Names

Input signals				Output signals			
No.	Signal description	Symbol	Pin No.	No.	Signal description	Symbol	Pin No.
0	Servo-ON	$\overline{\text{SRV-ON}}$	2 9	0	Servo-ready	$\overline{\text{S-RDY}}$	35 (34)
1	Alarm clear	$\overline{\text{A-CLR}}$	3 1	1	Servo alarm	$\overline{\text{ALM}}$	37 (36)
2	CW overtravel inhibit	$\overline{\text{CWL}}$	8	2	In-position	$\overline{\text{COIN}}$	39 (38)
3	CCW overtravel inhibit	$\overline{\text{CCWL}}$	9	3	Mechanical brake release	$\overline{\text{BRK-OFF}}$	11 (10)
4	Control mode switching	$\overline{\text{C-MODE}}$	3 2	4	Zero speed detection	$\overline{\text{ZSP}}$	12
5	Speed zero clamp	$\overline{\text{ZEROSPD}}$	2 6	5	Torque in-limit	$\overline{\text{TLC}}$	40
6	Command pulse scaler switch 1	$\overline{\text{DIV}}$	2 8	6	Internal use		
7	Internal use			7	Internal use		
8	Command pulse input inhibit	$\overline{\text{INH}}$	3 3	8	Internal use		
9	Gain switching	$\overline{\text{GAIN}}$	2 7	9	At-speed	$\overline{\text{COIN}}$	39 (38)
A	Counter clear	$\overline{\text{CL}}$	3 0	A	Internal use		
B	Internal use			B	Internal use		
C	Internal vel.cmnd. select 1	$\overline{\text{INH}}$	3 3	C	Internal use		
D	Internal vel.cmnd. select 2	$\overline{\text{CL}}$	3 0	D	Dynamic brake action	$\overline{\text{DBRK}}$	Internal signal
E	Internal use			E	Internal use		
F	Internal use			F	Internal use		
1 0	Internal use			1 0	Internal use		
1 1	Internal use			1 1	Internal use		
1 2	Internal use			1 2	Internal use		
1 3	Internal use			1 3	Internal use		
1 4	Internal use			1 4	Internal use		
1 5	Internal use			1 5	Internal use		
1 6	Internal use			1 6	Internal use		
1 7	Internal use			1 7	Internal use		
1 8	Internal use			1 8	Internal use		
1 9	Internal use			1 9	Internal use		
1 A	Internal use			1 A	Internal use		
1 B	Internal use			1 B	Internal use		
1 C	Internal use			1 C	Internal use		
1 D	Internal use			1 D	Internal use		
1 E	Internal use			1 E	Internal use		
1 F	Internal use			1 F	Internal use		

<Note>

The signals with symbol marked with $\overline{\quad}$ are active with L (on).

Viewing the causes and history of an alarm

- You can view the latest 14 alarms including the current one.

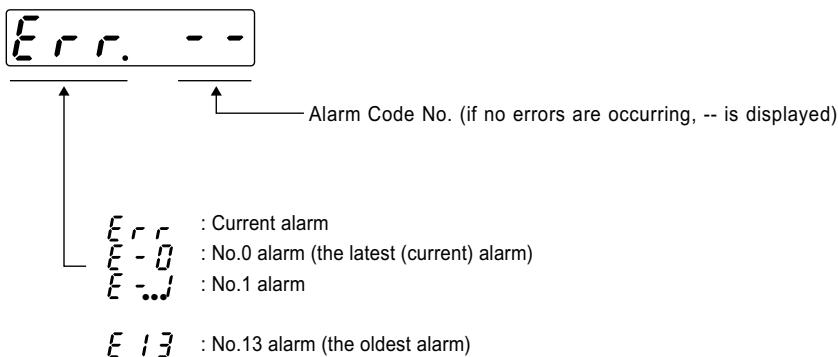

- ⊕ ⊖ To select any alarm event you wanted, press UP or DOWN button for access to the desired alarm No.
 (⊖ Pressing DOWN will move to older alarms.)

<Notes>

- If an alarm which is stored in the history memory is occurring, the alarm is given E-0 (Error-0).
- The alarm history cannot be deleted.

Alarm Numbers and Functions

Alarm Code No.	Function	Alarm Code No.	Function
1 1	Undervoltage, control power	2 7	Command pulse saler error
1 2	Overvoltage	2 8	External scale error
1 3	Undervoltage, main power	2 9	Error counter over flow
1 4	Overcurrent	3 5	External scale disconnection error
1 5	Overheat	3 6	EEPROM parameter error
1 6	Overload	3 7	EEPROM check code error
1 8	Regenerative discharge	3 8	Overtravel inhibit input error
2 0	Encoder A/B phase error	4 0	Absolute system down error
2 1	Encoder communication error	4 1	Absolute counter over flow error
2 2	Encoder connection error	4 2	Absolute over-speed error
2 3	Encoder communication data error	4 4	Absolute single-turn counter error
2 4	Position error	4 5	Absolute multi-turn counter error
2 5	Hybrid error	4 7	Absolute status error
2 6	Overspeed	Other than the above	Other errors

Details of Operation (Monitor Mode)

Alarm Display

The LCD display shows the characters 'r n' on the left, a hyphen '-' in the middle, and 'AA' on the right.

A : FAlarm occurred
- : FNo alarms occurred

Over-regeneration alarm: over 85% of the acceptable consumption of the regenerative discharge resistor

Overload alarm: over 85% of the acceptable load level

Battery alarm: under the acceptable voltage level

<Notes>

- The battery alarm is kept active until the control power is turned off.
- Other alarms are kept displayed at least one second after the alarm event occurs.
- Alarming criteria cannot be changed.

Display of the load factor of the regenerative discharge resistor

- Display the load factor of the regenerative discharge resistor as a percentage of the protective operation level (100%).

The LCD display shows the characters 'r G' on the left and '30' on the right.

↑ Acceptable load factor of the regenerative discharge resistor (unit : %)

- For an external regenerative discharge resistor, Pr6C should be 0 or 1 to display the load factor.

Display of the load factor

- Display the load factor as a percentage of the rated load (100%).

The LCD display shows the characters 'oL' on the left and '28' on the right.

↑ Load factor (unit : %)

- See "Overload Protection: Time Limiting Characteristic" in Appendix.

Operation in the Parameter Setting Mode

Operation in the Mode Selection mode

PA_ 00.

↑ ↑
Parameter No. (hexadecimal digit)

<Notes>

Display of "r" in this field means that the parameter has been modified, so it must be downloaded to EEPROM. After downloading, the parameter value is not valid until the power is turned off and turned on again.

- 1) Press  UP or  DOWN button to select a parameter No. that you want to view or edit.

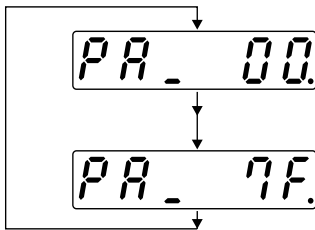

 Press UP button to scroll down (in the arrow direction).

 Press DOWN button to scroll up.

- 2)  Press SET button to switch to Monitor/Execution mode.

Operation in the Monitor/Execution mode



1000.

↑ ↑
The digit with the decimal point in blinking is the digit that you can modify the value.
Parameter value



- 1)  Using LEFT button, move the decimal point to a digit that you want to edit

<Note>

How many digits you can move the decimal point leftward differs depending on the parameter.

- 2) Press  UP or  DOWN button to select a desired value.

<Note>

Pressing  UP will increase the value. Pressing  DOWN will decrease the value. This setting (modification) of value will immediately affect the control.

Details of Parameters (Auxiliary Function Mode)

Auxiliary Function Mode

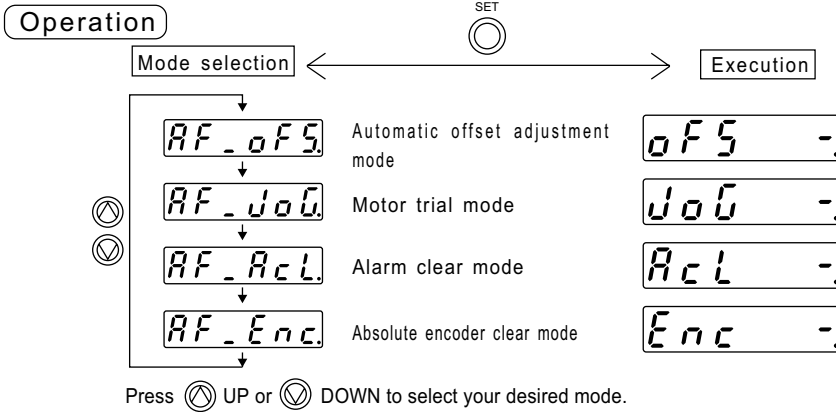

Automatic Offset Adjustment Mode

This mode is to set the voltage of analogue velocity (or torque) commands to 0V, measure the offset during Servo-OFF, and correct the offset so that small motions (rotation) can be eliminated. This automatic offset adjustment mode should be started by the following procedure.

Procedure

- 1) Select the automatic offset adjustment mode using the procedure mentioned above.

AF_oFS will appear. Press SET ^{SET}⊙ button to display oFS -.

- 2) The mode is ready for execution.

⊙ Keep pressing UP button (for about three seconds). The number of short bars (-) will increase.

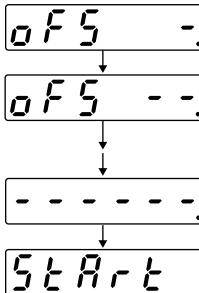

The mode is started.

The adjustment will complete instantaneously.

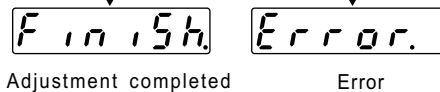

<Notes>

1. The automatic offset adjustment mode is not effective for the position control mode.
2. If the input voltage is over the adjustment range ($\pm 25\%$ of the maximum input voltage), the mode cannot work (an error occurs). Make sure that the input voltage is 0V.
3. If the value of Pr52 produced by the mode (i.e. the result of the offset adjustment) is not downloaded to EEPROM before turning off the power, the value will be lost (the previous value remains). If you want to continue to use the new value, download it to EEPROM before turning off the power.

Alarm Clear Mode

Clearing an alarm using the LED touch panel is the same as removing the trip status by using the alarm clear signal (A-CLR).

Procedure

- 1) Select the alarm clear mode (refer to page 39 in Appendix). **AF_AcL** will appear.

Press SET  button to display **AcL -**.

- 2) The mode is ready for execution.

 Keep pressing UP button (for about three seconds). The number of short bars (-) will increase.

The mode is started.

The clearing operation will complete instantaneously.

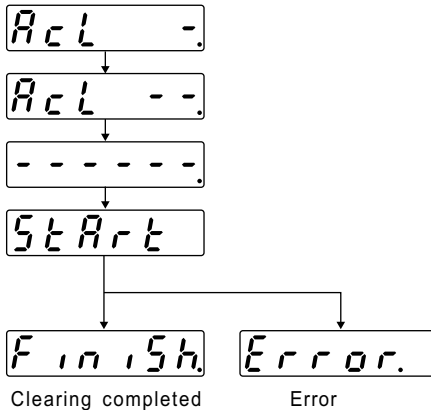

<Notes>

If one of the errors shown below is occurring, the trip status is not removed, and

Error. appears.

In this case, remove the error by turning off the power, removing the cause and turning on the power again.

Over-current, overheat, encoder A/B phase error, encoder communication error, encoder disconnection, encoder communication data error, EEPROM parameter error, EEPROM check code error, absolute single-turn counter error, absolute multi-turn counter error and Other error

Details of Parameters (Auxiliary Function Mode)

Absolute Encoder Clear Mode

This mode is to clear the multi-turn data of the absolute encoder, and clear the alarms regarding the encoder.

Procedure

1) Select the absolute encoder clear mode (refer to page 39 in Appendix). `AF_Enc.` will appear. Press SET  button to display `Enc -.`

2) The mode is ready for execution.

 Keep pressing UP button (for about three seconds). The number of short bars (-) will increase.

The mode is started.

The clearing operation will complete instantaneously.

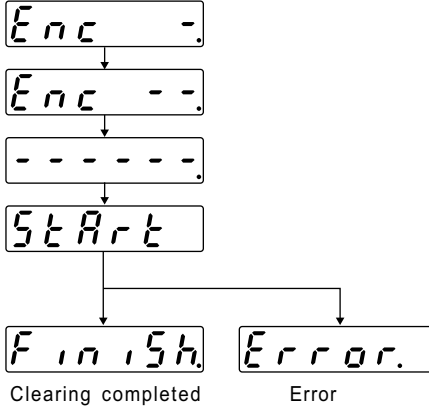

<Notes>

If you execute this mode for a driver with an incremental encoder,

`Error.` will appear.

After executing the absolute encoder clear mode, turn off the power of the driver, and then turn it on again.

Overview of a Communication Control Software PANATERM

How to Connect

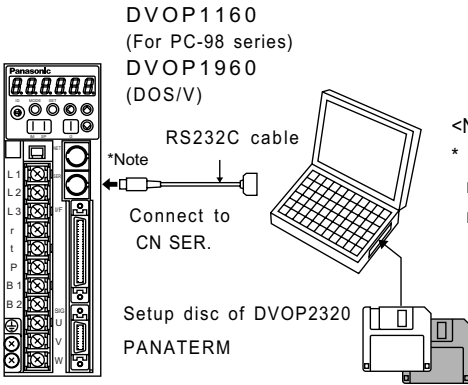

<Note>

* Do not connect to CN NET. Otherwise an error message meaning that PANATERM cannot detect the communication port or driver will appear.

Installing PANATERM on a hard disc

<Notes>

1. The memory capacity of the hard disc should be 15MB or more.
2. Install PANATERM with setup discs, otherwise the software does not work.

Installation Procedure

- 1) Turn on your personal computer. Start Windows95 (or 98). (Note: if there is any application program on, close all of them.)
- 2) Insert the PANATERM Setup Disc 1 into the floppy disc drive.
- 3) Start Explorer, and switch to (select) the floppy disc drive. (For the procedure for starting the Explorer program, see the instructions for Windows.)
- 4) Double click on "Setup.exe" (PANATERM Setup program will start).
- 5) Click on to start the setup program.
- 6) Keep the operation according to the guide of the setup program.
- 7) Click on to start the setup routine.
- 8) Confirm an message "Setup completed". Then click on .
- 9) Close all the applications. Then restart Windows. PANATERM will be added to the program menu.

Overview of a Communication Control Software PANATERM

Starting PANATERM

<Notes>

1. Once you install PANATERM on your hard disc, you do not have to install it again for next use.
2. Before using PANATERM, the driver, power supply, motor and encoder should be connected. For the procedure for starting PANATERM, see the Windows manual.

Procedure

- 1) Turn on your personal computer. Start Windows95 (or 98).
- 2) Turn on the driver.
- 3) Click on the start button of Windows (see the Windows manual).
- 4) Select (click on) PANATERM from the program menu.
- 5) An opening splash will be displayed for two seconds, and then PANATERM screen will appear.

For the operation, functions and other details about PANATERM, see the Instructions for the PANATERM program.

Optional Parts

MINAS-A series Cables

Dwg. No.	Motor type	Cable	Part No.	Remarks
1 - 1	MSMA30 ~ 750W MQMA100 ~ 400W	Encoder cable (17 bits, 7 wires) for absolute/incremental encoders	MFECAO**OLAA	
2 - 1		Encoder cable (2500 pulses, 11 wires), incremental encoders	MFECAO**OEAA	
3 - 1		Motor cable	MFMCAO**OEET	
4 - 1		Brake cable	MFMCBO**OGET	
1 - 2	MSMA1.0 ~ 2.5kW MDMA750W ~ 2.5kW	Encoder cable (17 bits, 7 wires) for absolute/incremental encoders	MFECAO**OLSA	
2 - 2		Encoder cable (2500 pulses, 11 wires), incremental encoders	MFECAO**OESA	
3 - 2	MHMA500W ~ 1.5kW MGMA300 ~ 900W	Motor cable	MFMCDO**2ECT	
4 - 2		Brake cable(With brake)	MFMCAO**2FCT	
1 - 2	MSMA3.0 ~ 5.0kW MDMA3.0 ~ 5.0kW	Encoder cable (17 bits, 7 wires) for absolute/incremental encoders	MFECAO**OLSA	
2 - 2		Encoder cable (2500 pulses, 11 wires), incremental encoders	MFECAO**OESA	
3 - 3	MHMA2.0 ~ 5.0kW MGMA1.2 ~ 4.5kW	Motor cable	MFMCAO**3ECT	
4 - 3		Brake cable(With brake)	MFMCAO**3FCT	
1 - 2	MFMA400W ~ 1.5kW	Encoder cable (17 bits, 7 wires) for absolute/incremental encoders	MFECAO**OLSA	
2 - 2		Encoder cable (2500 pulses, 11 wires), incremental encoders	MFECAO**OESA	
3 - 4		Motor cable	MFMCAO**2ECT	
4 - 2		Brake cable(With brake)	MFMCAO**2FCT	
1 - 2	MFMA2.5 ~ 4.5kW	Encoder cable (17 bits, 7 wires) for absolute/incremental encoders	MFECAO**OLSA	
2 - 2		Encoder cable (2500 pulses, 11 wires), incremental encoders	MFECAO**OESA	
3 - 5		Motor cable	MFMCDO**3ECT	
4 - 3		Brake cable(With brake)	MFMCAO**3FCT	

Optional Parts

Encoder Cables

fig1-1 MFECA0**0LAA

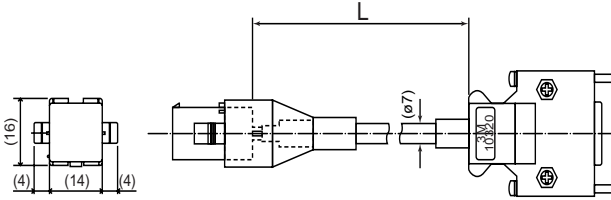

L (m)	Part No.
3	MFECA0030LAA
5	MFECA0050LAA
10	MFECA0100LAA
20	MFECA0200LAA

fig1-2 MFECA0**0LSA

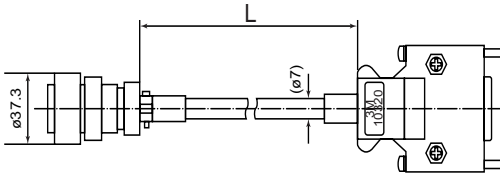

L (m)	Part No.
3	MFECA0030LSA
5	MFECA0050LSA
10	MFECA0100LSA
20	MFECA0200LSA

fig2-1 MFECA0**0EAA

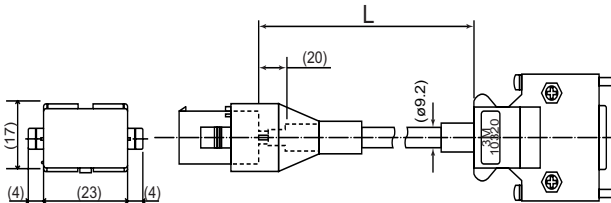

L (m)	Part No.
3	MFECA0030EAA
5	MFECA0050EAA
10	MFECA0100EAA
20	MFECA0200EAA

fig2-2 MFECA0**0ESA

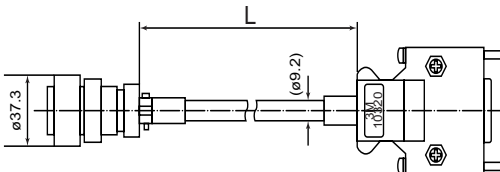

L (m)	Part No.
3	MFECA0030ESA
5	MFECA0050ESA
10	MFECA0100ESA
20	MFECA0200ESA

Motor Cables (RobotopR, 600V DP)

Robotop is the trademark of Sumitomo Denso.

fig 3-1

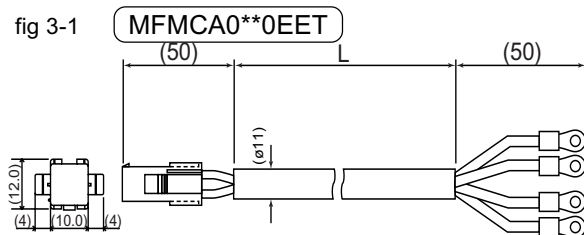

L (m)	Part No.
3	MFMCA0030EET
5	MFMCA0050EET
10	MFMCA0100EET
20	MFMCA0200EET

fig 3-2

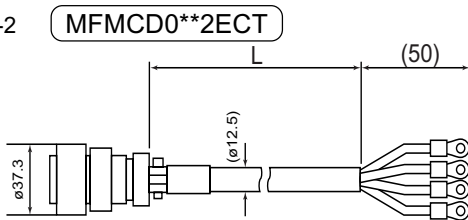

L (m)	Part No.
3	MFMCD0032ECT
5	MFMCD0052ECT
10	MFMCD0102ECT
20	MFMCD0202ECT

fig 3-3

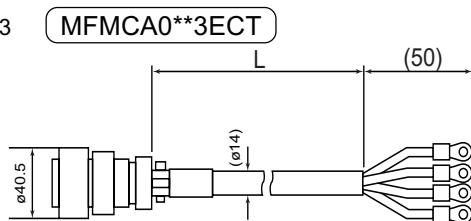

L (m)	Part No.
3	MFMCA0033ECT
5	MFMCA0053ECT
10	MFMCA0103ECT
20	MFMCA0203ECT

fig 3-4

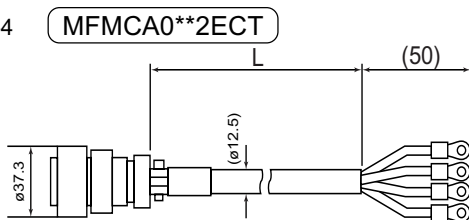

L (m)	Part No.
3	MFMCA0032ECT
5	MFMCA0052ECT
10	MFMCA0102ECT
20	MFMCA0202ECT

fig 3-5

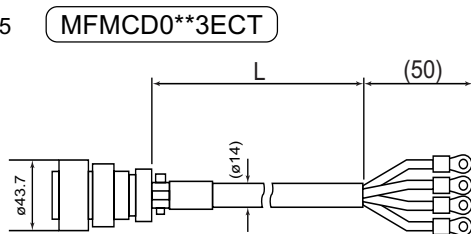

L (m)	Part No.
3	MFMD0033ECT
5	MFMD0053ECT
10	MFMD0103ECT
20	MFMD0203ECT

Optional Parts

Motor (with Brake) Cables (Robotop[®], 600V Δ DP)

fig 4-1 MFMCB0**0GET (Brake cable)

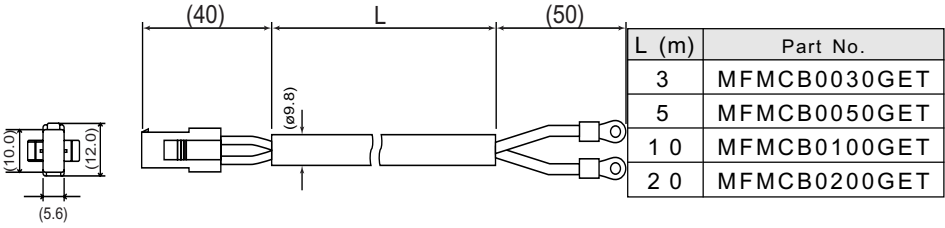

fig 4-2 MFMCA0**2FCT

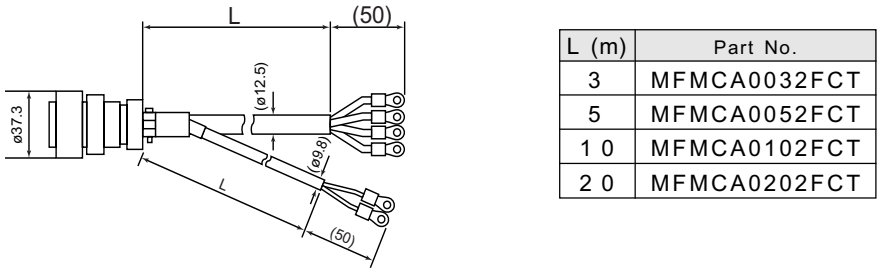
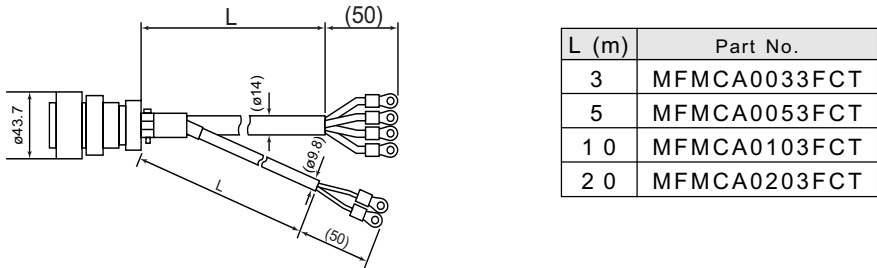

fig 4-3 MFMCA0**3FCT



Connector Kits for External Equipment

1) Part No. DV0P0980

2) Components

Item	Manufacturer's Part No.	Quantity	Manufacturer	Remarks
Plug	10150-3000VE	1	SUMITOMO	For CN I/F (50 pins)
Shell	10350-52A0-008	1	3 M	

3) Alignment of CN I/F (50 pins) (Looking from where the plug is soldered)

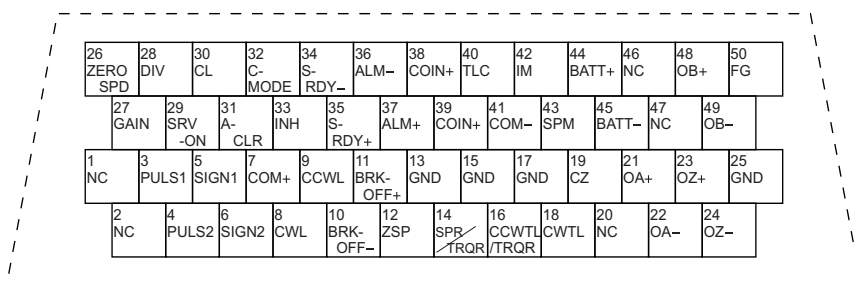

<Notes>

1. Before making connections, check the Pin Numbers stamped on the plugs.
2. For the symbols and functions of the pins, see the section "CN I/F Connector" in the main part of this manual.
3. Pins marked with NC should be left unconnected.

Optional Parts

Connector Kits for Motor and Encoder

- Used for: MSMA 30W to 750W
MQMA 100w to 400W [with a 17-bit absolute encoder]

1) Part No. DVOP2110

2) Components

Item	Manufacturer's Part No.	Quantity	Manufacturer	Remarks
Plug	10120-3000VE	1	Sumitomo	For CN I/SIG (20pin)
Shell	10320-52A0-008	1	3M	
Cap	172161-1	1	AMP	For encoder cable (9 pins)
Socket	170365-1	9		
Cap	172159-1	1	AMP	For motor cable (4 pins)
Socket	170366-1	4		

- Used for: MSMA 30W to 750W
MQMA 100w to 400W [with a 2500-pulse,
11-wire incremental encoder]

1) Part No. DVOP0490

2) Components

Item	Manufacturer's Part No.	Quantity	Manufacturer	Remarks
Plug	10120-3000VE	1	Sumitomo	For CN I/SIG (20pin)
Shell	10320-52A0-008	1	3M	
Cap	172163-1	1	AMP	For encoder cable (15 pins)
Socket	170365-1	15		
Cap	172159-1	1	AMP	For motor cable (4 pins)
Socket	170366-1	4		

- Used for : MSMA 1.0kW to 2.5kW
MDMA 0.75kW to 2.5kW
MHMA 0.5kW to 1.5kW
MGMA 300W to 900kW

[with a 17-bit absolute/incremental encoder or 2500-pulse incremental encoder]
without brake

1) Part No. DVOP0960

2) Components

Item	Manufacturer's Part No.	Quantity	Manufacturer	Remarks
Plug	10120-3000VE	1	Sumitomo	For CN I/SIG (20pin)
Shell	10320-52A0-008	1	3M	
Straight plug	MS3106B20-29S	1	Japan Aviation	For encoder cable
Cable clamp	MS3057-12A	1	Electronics Industry, Ltd.	
Straight plug	MS3106B20-4S	1	Japan Aviation	For motor cable
Cable clamp	MS3057-12A	1	Electronics Industry, Ltd.	

- Used for : MSMA 3.0kW to 5.0kW
MDMA 3.0kW to 5.0kW
MHMA 2.0kW to 5.0kW
MGMA 1.2kW to 4.5kW

[with a 17-bit absolute/incremental encoder or 2500-pulse incremental encoder]
without brake

1) Part No. DVOP1510

2) Components

Item	Manufacturer's Part No.	Quantity	Manufacturer	Remarks
Plug	10120-3000VE	1	Sumitomo	For CN I/SIG (20pin)
Shell	10320-52A0-008	1	3M	
Straight plug	MS3106B-20-29S	1	Japan Aviation	For encoder cable
Cable clamp	MS3057-12A	1	Electronics Industry, Ltd.	
Straight plug	MS3106B22-22S	1	Japan Aviation	For motor cable
Cable clamp	MS3057-12A	1	Electronics Industry, Ltd.	

Optional Parts

- Used for : MSMA 1.0kW to 2.5kW
 MDMA 0.75kW to 2.5kW
 MHMA 0.5kW to 1.5kW
 MGMA 300W to 900W
 MFM 0.4kW to 1.5kW
- with a 17-bit absolute/incremental encoder or 2500-pulse incremental encoder
 with brake
- with a 17-bit absolute/incremental encoder or 2500-pulse incremental encoder
 without brake
 with brake

1) Part No. DVOP0690

2) Components

Item	Manufacturer's Part No.	Quantity	Manufacturer	Remarks
Plug	10120-3000VE	1	Sumitomo	For CN I/SIG (20pin)
Shell	10320-52AO-008	1	3M	
Straight plug	MS3106B20-29S	1	apan Aviation	For encoder cable
Cable clamp	MS3057-12A	1	Electronics Industry, Ltd.	
Straight plug	MS3106B20-18S	1	Japan Aviation	For motor cable
Cable clamp	MS3057-12A	1	Electronics Industry, Ltd.	

- Used for : MSMA 3.0kW to 5.0kW
 MDMA 3.0kW to 5.0kW
 MHMA 2.0kW to 5.0kW
 MGMA 1.2kW to 4.5kW
 MFM 2.5kW to 4.5kW
- with a 17-bit absolute/incremental encoder or 2500-pulse incremental encoder
 with brake
- with a 17-bit absolute/incremental encoder or 2500-pulse incremental encoder
 without brake
 with brake

1) Part No. DVOP0970

2) Components

Item	Manufacturer's Part No.	Quantity	Manufacturer	Remarks
Plug	10120-3000VE	1	Sumitomo	For CN I/SIG Ä20pin)
Shell	10320-52AO-008	1	3 M	
Straight plug	MS3106B20-29S	1	apan Aviation	For encoder cable
Cable clamp	MS3057-12A	1	Electronics Industry, Ltd.	
Straight plug	MS3106B24-11S	1	Japan Aviation	For motor cable
Cable clamp	MS3057-16A	1	Electronics Industry, Ltd.	

<Notes>

1. Plugs, shells and other parts may be equivalents of other manufacturer's make.
2. Alignment of CN SIG pins

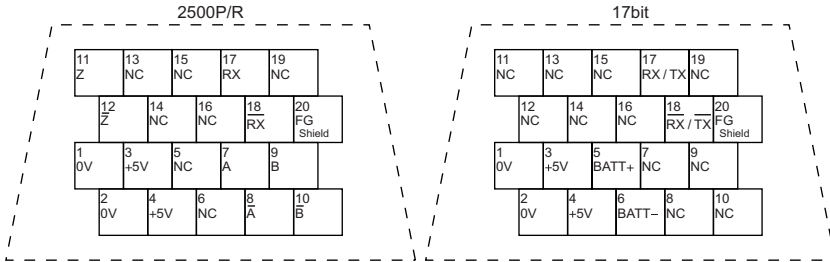

<Notes>

1. The tables above show the pins alignment, looking from where the plugs are soldered.
2. The pin 20 (FG) should be connected to the shield of the shielded wire. Pins marked with NC should be left unconnected.
3. For the use of these pins, see the section "CN SIG Connector (for Encoder)" in the main part of this manual.

Optional Parts

Interface Cables

1) Part No. DVOP2190

2) Dimension

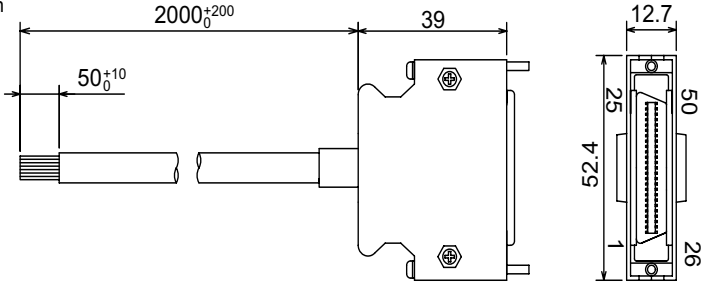

3) Wire table

Pin No.	Wire color	Pin No.	Wire color	Pin No.	Wire color	Pin No.	Wire color	Pin No.	Wire color
1	Orange (Red 1)	1 1	Orange (Brack 2)	2 1	Orange (Red 3)	3 1	Orange (Red 4)	4 1	Orange (Red 5)
2	Orange (Brack1)	1 2	Yellow (Brack 1)	2 2	Orange (Brack3)	3 2	Orange (Brack4)	4 2	Orange (Brack5)
3	Gray (Red 1)	1 3	Gray (Red 2)	2 3	Gray (Red 3)	3 3	Gray (Red 4)	4 3	Gray (Red 5)
4	Gray (Brack 1)	1 4	Gray (Brack 2)	2 4	Gray (Brack 3)	3 4	White(Red 4)	4 4	White(Red 5)
5	White (Red 1)	1 5	White (Red 2)	2 5	White (Red 3)	3 5	White (Brack4)	4 5	White((Brack5)
6	White (Brack 1)	1 6	Yellow (Red 2)	2 6	White (Brack3)	3 6	Yellow (Red 4)	4 6	Yellow (Red 5)
7	Yellow (Red 1)	1 7	Yellow (Brack 1) (EPin)(Brack 2)	2 7	Yellow (Red 3)	3 7	Yellow (Brack4)	4 7	Yellow (Brack5)
8	Pink (Red 1)	1 8	Pink (Red 2)	2 8	Yellow (Brack3)	3 8	Pink (Red 4)	4 8	Pink (Red 5)
9	Pink (Brack 1)	1 9	White (Brack2)	2 9	Pink (Red 3)	3 9	Pink (Brack 4)	4 9	Pink (Brack 5)
1 0	Orange (Red2)	2 0	—	3 0	Pink (Brack 3)	4 0	Gray (Brack 4)	5 0	Gray (Brack 5)

<Notes>

For example, Orange (Red 1) for Pin No.1 means that the lead wire is colored in orange with one dot mark in red.

Communication Cables (for connection to personal computer)

1) Part No. DVOP1160 (for PC98 series)

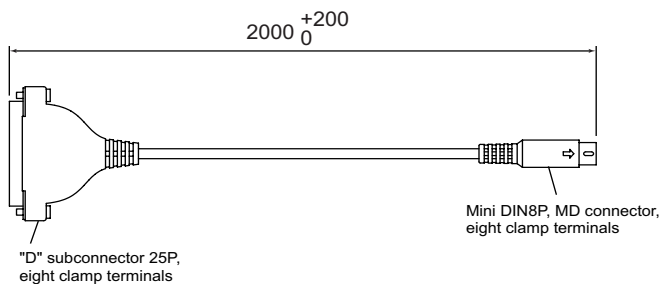

2) Part No. DVOP1960 (for DOS/V)

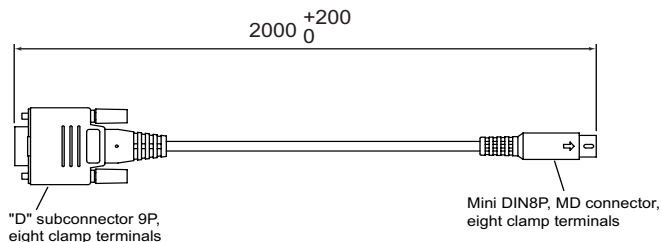

Communication Cables (for RS485)

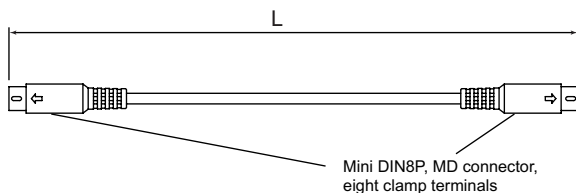

Part No.	L [mm]
DVOP1970	200
DVOP1971	500
DVOP1972	1000

Communication Control Software PANATERM

1) Part No. DVOP2320

2) 3.5 inch floppy disc

\<Note>

For the operating environment and other details, see the Instructions for PANATERM.

Optional Parts

Brackets for Mounting the Driver

Driver type	Part No.	Screws *1	Outer dimension
Type 1	DVOP 2100	M3 x 8 pan head screw x 4 pcs.	<p>Upper and lower brackets (each 1) for front panel mounting</p>
Type 2・3	DVOP 2101	M3 x 8 pan head screw x 4 pcs.	<p>2-M3 pan head screw</p>
Type 4-2 4-3	DVOP 2102	M4x 6 pan head screw x 4 pcs.	<p>Brackets (2) for back panel mounting</p>

*1 The mounting screws are supplied together with the brackets.

<Notes>

Type-5 drivers can be secured in either way of front panel mounting or back panel mounting. To change the mounting method, change the L-shape brackets supplied.

External Regenerative Discharge Resistor

Part.No.	Product number	Model	
		Specifications	Resistance
DV0P1980	RH150M	50Ω	90 W
DV0P1981	RH150M	100Ω	90 W
DV0P1982	RH220M	30Ω	120 W
DV0P1983	RH500M	20Ω	300 W

Manufacturer: IWAKI MUSEN KENKYUSHO CO., LTD.

Recommended combination between driver and external regenerative discharge resistor

Driver type	Power supply	
	Single-phase 100V	Three-phase 200V
1	DVOP1980 x 1	DVOP1981 x 1
2		
3		
4-2 4-3	/	DVOP1982 x 2 (in parallel) or DVOP1983 x 1
5		DVOP1982 x 2 ^Δ 3 (in parallel) or DVOP1983 x 1 or 2 (in parallel)

For driver types, see pages 10 and 11 (main part) and pages 7 and 8 (Appendix).

RH150M, RH220M

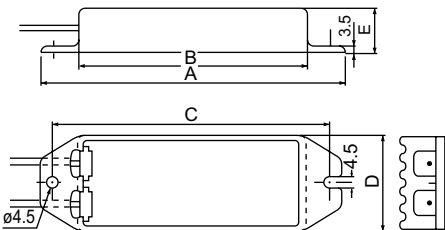

Lead wires : 300mm

	A	B	C	D	E
RH150	212	180	202	44	30
RH220	230	200	220	60	20

RH500M

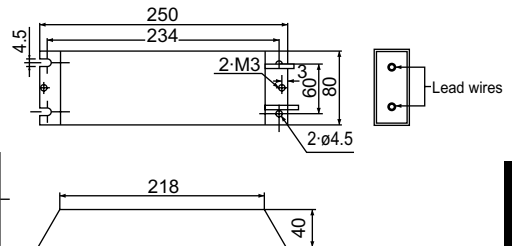

Lead wires : 450mm

Optional Parts

Battery and Battery Holder for Absolute Encoder

Battery (for driver types 1 to 5)

A Part No. DVOP2060

B Lithium battery, Toshiba Battery make
ER6V, 3.6V, 2000mAh

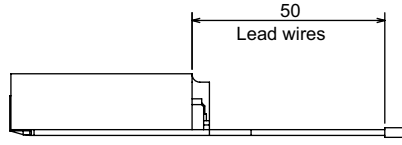

Battery Holder (for driver types 1 to 3)

A Part No. DVOP2061

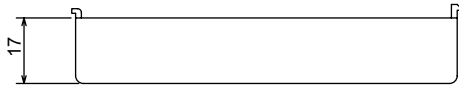

<Notes>

Driver types 4-2, 4-3 and 5 do not need the battery holder.

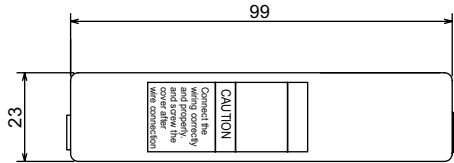

Absolute Driver (with battery): Outer Dimension

Driver Types 1 through 3

Driver type	Dimension	
	L	LL
1 A` 2	130	147
3	170	187

<Notes>

Absolute drivers of types 4-2, 4-3 and 5 have the same dimension as the standard type.

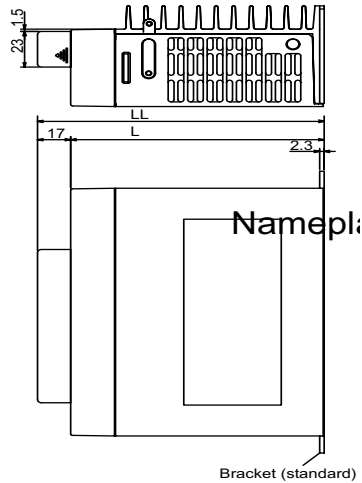

Reactre

Driver series	Voltage	Rated output	Reactor Part No.	Driver series	Voltage	Rated output	Reactor Part No.
MSDA	100V	30W ~ 100W		MSDA	200V	2.0kW	DVOP223
MQDA		100W	DVOP222	MDDA			
MSDA		200W ~ 400W		MHDA			
MQDA			DVOP220	MGDA		2.0kW	DVOP224
MSDA	200V	30W ~ 400W		MSDA		2.5kW	
MQDA		100W ~ 400W		MDDA			
MGDA		300W		MFDA			
MFDA		400W		MSDA		3.0kW	
MHDA		500W	DVOP221	MDDA			
MGDA		600W		MHDA			
MSDA		750W		MGDA			
MDDA				MSDA		3.5kW	
MFDA			DVOP222	MDDA			
MGDA		900W, 1.2kW		MFDA			
MSDA		1.0kW		MSDA	4.0kW	DVOP225	
MDDA		1.5kW		MDDA			
MHDA				MFDA			
MFDA		1.5kW					

Recommended Parts

Surge Absorber for Motor Brake

motor	Surge absorber for brake
MSMA30W ~ 1.0kW	<ul style="list-style-type: none"> C-5A2 or Z15D151 Ishizuka.co.
MQMA100W ~ 400W	
MHMA2.0kW ~ 5.0kW	
MGMA600W ~ 2.0kW	
MSMA1.5kW ~ 5.0kW	<ul style="list-style-type: none"> C-5A3 or Z15D151 Ishizuka.co.
MDMA750W	
MDMA3.5kW ~ 5.0kW	
MFMA750W ~ 1.5kW	
MGMA3.0kW ~ 4.5kW	<ul style="list-style-type: none"> TNR9G820K NIPPON CHEMICAL CON CO.
MDMA1.0kW ~ 3.0kW	
MFMA400W	
MFMA2.5kW ~ 4.5kW	
MHMA500W ~ 1.5kW	
MGMA300W	

Peripheral Equipment Manufacturers

3.1999.present

Manufacturer/agent	Tel	Equipment
Matsushita Electric Works, Ltd.	06-6908-1131	No-fuse breaker, magnetic contact and surge absorber
IWAKI MUSEN KENKYUSHO CO., LTD.	044-833-4311	Regenerative discharge resistor
NIPPON CHEMI_CON CORPORATION	Kantou Area 03-5436-7608 Chub Area 052-772-8551 Kansai Ares 06-6338-2331	Surge absorber for Brake
Ishizuka Electronics Corporation	Kantou Area 03-3621-2703 Chub Area 052-777-5070 Kansai Ares 06-6391-6491	
Token Corporation	Kantou Area 03-3475-6814 Chub Area 052-581-9336 Kansai Ares 06-6263-6781	Noise Filter
TDK Corporation	Kantou Area 03-5201-7229 Chub Area 052-971-1712 Kansai Ares 06-6245-7333	Noise filter for signal line
Okaya Electric Industries Co., Ltd.	East Japan 03-3424-8120 West Japan 06-6392-1781	Surge absorber / Noise filter
Japan Aviation Electronics Industry, Ltd.	Kantou Area 03-3780-2717 Chub Area 052-953-9520 Kansai Ares 06-6447-5259	Connector
Sumitomo 3M	Kantou Area 03-5716-7290 Chub Area 052-322-9652 Kansai Ares 06-6447-3944	
AMP (JAPAN), LTD.	Kantou Area 044-844-8111 Chub Area 0565-29-0890 Kansai Ares 06-6251-4961	

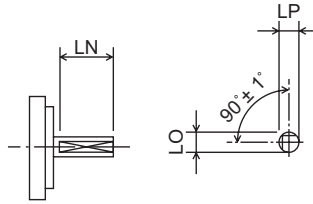

"D" cut type

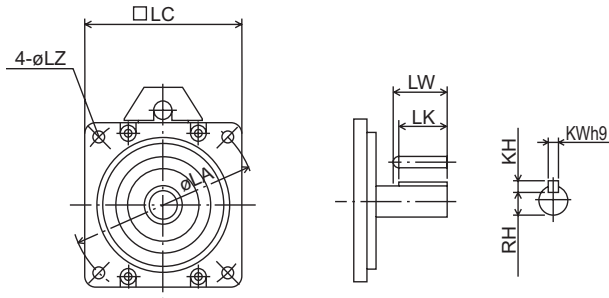

Key way type

		LR	LZ	LW	LK	KW	KH	RH	LN	LO	LP	Weight (kg)
M S M A	Without brake	25	3.4	13	12	2	2	5.8	20	6.5	6.5	0.27
				14	12.5	3	3	6.2		7.5	7.5	0.34
		30	4.5	20	18	4	4	8.5	22	10	10	1.0
				25	22.5	5	5	11		12.5	12.5	1.6
		35	6		22	6	6	15.5	25	17.5	17.5	3.2
		25	3.4	13	12	2	2	5.8	20	6.5	6.5	0.33
	14			12.5	3	3	6.2	7.5		7.5	0.40	
	30	4.5	20	18	4	4	8.5	22	10	10	1.1	
			25	22.5	5	5	11		12.5	12.5	1.7	
	35	6		22	6	6	15.5	25	17.5	17.5	3.3	
	With brake	25	3.4	13	12	2	2	5.8	20	6.5	6.5	0.47
				14	12.5	3	3	6.2		7.5	7.5	0.53
30		4.5	20	18	4	4	8.5	22	10	10	1.4	
			25	22.5	5	5	11		12.5	12.5	2.0	
35		6		22	6	6	15.5	25	17.5	17.5	3.9	
25		3.4	13	12	2	2	5.8	20	6.5	6.5	0.53	
	14		12.5	3	3	6.2	7.5		7.5	0.59		
											0.82	
30	4.5	20	18	4	4	8.5	22	10	10	1.5		
		25	22.5	5	5	11		12.5	12.5	2.1		
35	6		22	6	6	15.5	25	17.5	17.5	4.0		

Dimensions

MSMA Series 1.0 ~ 5.0kW

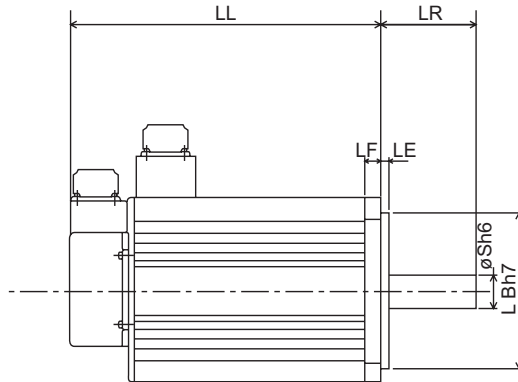

○ Encoder specifications

A1 □ 2500 P/r incremental encoder

D1 □ 17 bits absolute encoder

		Model	Output(W)	LL	S	LA	LB	LC	LD	LE
MSMA	Without brake	MSMA102A1□	1.0	172	19	100	80	90	120	3
		MSMA152A1□	1.5	177		115	95	100	135	
		MSMA202A1□	2.0	202	22	A\	110	120	162	6
		MSMA252A1□	2.5	227						
		MSMA302A1□	3.0	214						
		MSMA352A1□	3.5	234						
		MSMA402A1□	4.0	237	24	145	130	165	6	
		MSMA452A1□	4.5	257						
		MSMA502A1□	5.0	277						
		MSMA102D1□	1.0	172	19	100	80	90	120	3
	MSMA152D1□	1.5	177	115		95	100	135		
	MSMA202D1□	2.0	202	22	A\	110	120	162	6	
	MSMA252D1□	2.5	227							
	MSMA302D1□	3.0	214							
	MSMA352D1□	3.5	234							
	MSMA402D1□	4.0	237	24	145	130	165	6		
	MSMA452D1□	4.5	257							
	MSMA502D1□	5.0	277							
	With brake	MSMA102A1□	1.0	197	19	100	80	90	120	3
		MSMA152A1□	1.5	202		115	95	100	135	
MSMA202A1□		2.0	227	22	A\	110	120	162	6	
MSMA252A1□		2.5	252							
MSMA302A1□		3.0	239							
MSMA352A1□		3.5	259							
MSMA402A1□		4.0	262	24	145	130	165	6		
MSMA452A1□		4.5	282							
MSMA502A1□		5.0	302							
MSMA102D1□		1.0	197	19	100	80	90	120	3	
MSMA152D1□	1.5	202	115		95	100	135			
MSMA202D1□	2.0	227	22	A\	110	120	162	6		
MSMA252D1□	2.5	252								
MSMA302D1□	3.0	239								
MSMA352D1□	3.5	259								
MSMA402D1□	4.0	262	24	145	130	165	6			
MSMA452D1□	4.5	282								
MSMA502D1□	5.0	302								

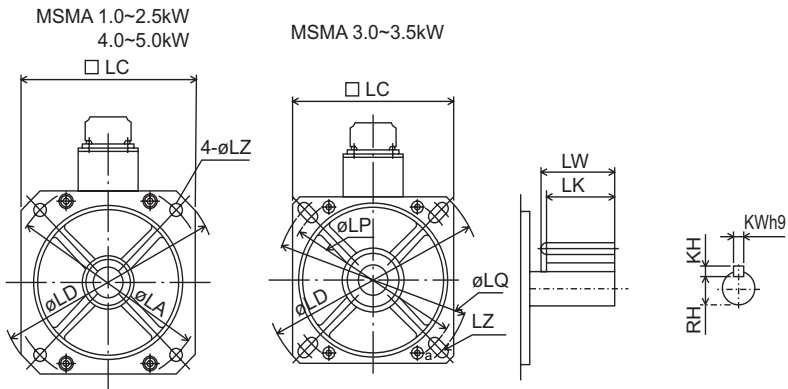

		LF	LP	LQ	LR	LZ	LW	LK	KW	KH	RH	Weight (kg)	
M S M A	without brake	7	—	—	5 5	6.6	4 5	4 2	6	6	15.5	4.5	
		10				9							5.1
						wide 9						4 1	8
		1 2	130	145									7.5
			—	—	6 5	9	5 5	5 1			2 0		9.3
													10.9
													12.9
													15.1
													17.3
		7			5 5	6.6	4 5	4 2	6	6	15.5	4.5	
		10				9						5.1	
						wide 9		4 1	8	7	1 8	6.5	
	1 2	130	145									7.5	
		—	—	6 5	9	5 5	5 1			2 0		9.3	
												10.9	
												12.9	
												15.1	
												17.3	
	7			5 5	6.6	4 5	4 2	6	6	15.5	5.1		
	10				9						6.5		
					wide 9		4 1	8	7	1 8	7.9		
	1 2	130	145									8.9	
		—	—	6 5	9	5 5	5 1			2 0		11.0	
												12.6	
											14.8		
											17.0		
											19.2		
7			5 5	6.6	4 5	4 2	6	6	15.5	5.1			
10				9						6.5			
				wide 9		4 1	8	7	1 8	7.9			
1 2	130	145									8.9		
	—	—	6 5	9	5 5	5 1			2 0		11.0		
											12.6		
											14.8		
											17.0		
											19.2		

Dimensions

MQMA Series 100W ~ 400W

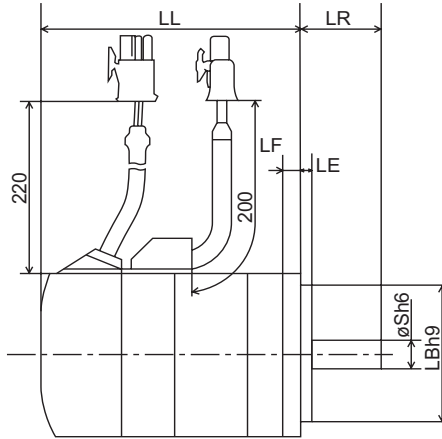

○ Encoder specifications

A1 □ 2500 P/r incremental encoder

D1 □ 17 bits absolute encoder

		Model	Output(W)	LL	S	LA	LB	LC	LE
MQMA	Without brake	MQMA01□A1□	100	60	8	70	50	60	3
		MQMA02□A1□	200	67	11	90	70	80	5
		MQMA04□A1□	400	82	14				
		MQMA01□C1□	100	87	8	70	50	60	3
		MQMA02□C1□	200	94	11	90	70	80	5
		MQMA04□C1□	400	109	14				
	With brake	MQMA01□A1□	100	84	8	70	50	60	3
		MQMA02□A1□	200	99.5	11	90	70	80	5
		MQMA04□A1□	400	114.5	14				
		MQMA01□C1□	100	111	8	70	50	60	3
		MQMA02□C1□	200	126.5	11	90	70	80	5
		MQMA04□C1□	400	141.5	14				

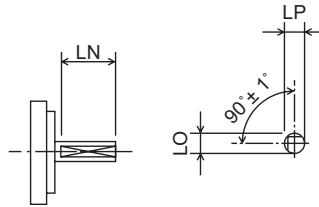

"D" cut type

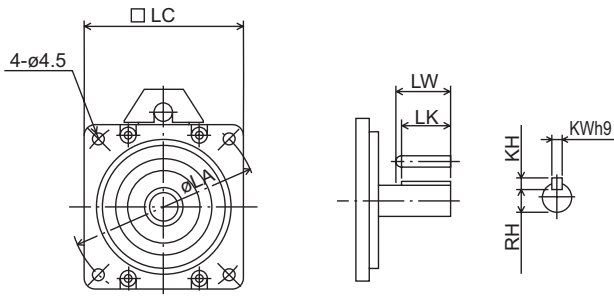

		LF	LR	LW	LK	KW	KH	RH	LN	LO	LP	Weight (kg)
MQA	Without brake	7	2.5	1.4	12.5	3	3	6.2	2.0	7.5	7.5	0.65
		8	3.0	2.0	1.8	4	4	8.5	2.2	1.0	1.0	1.3
				2.5	22.5	5	5	1.1		12.5	12.5	1.8
		7	2.5	1.4	12.5	3	3	6.2	2.0	7.5	7.5	0.75
		8	3.0	2.0	1.8	4	4	8.5	2.2	1.0	1.0	1.4
				2.5	22.5	5	5	1.1		12.5	12.5	1.9
	With brake	7	2.5	1.4	12.5	3	3	6.2	2.0	7.5	7.5	0.9
		8	3.0	2.0	1.8	4	4	8.5	2.2	1.0	1.0	2.0
				2.5	22.5	5	5	1.1		12.5	12.5	2.5
		7	2.5	1.4	12.5	3	3	6.2	2.0	7.5	7.5	1.0
		8	3.0	2.0	1.8	4	4	8.5	2.2	1.0	1.0	2.1
				2.5	22.5	5	5	1.1		12.5	12.5	2.6

Dimensions

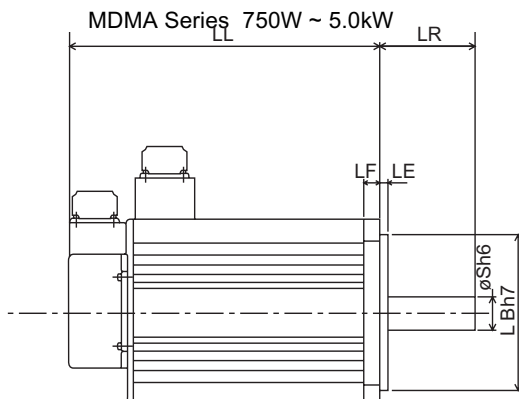

○ Encoder specifications

A1 □ 2500 P/r incremental encoder

D1 □ 17 bits absolute encoder

		Model	Output(W)	LL	S	LA	LB	LC	LD	LE
M D M A	Without brake	MDMA082A1□	0.75	144	19	—	110	120	162	3
		MDMA102A1□	1.0	147	22	145		130	165	6
		MDMA152A1□	1.5	172	24	165	130	150	190	3.2
		MDMA202A1□	2.0	197						
		MDMA252A1□	2.5	222						
		MDMA302A1□	3.0	247	35	200	114.3	176	233	
		MDMA352A1□	3.5	219						
		MDMA402A1□	4.0	239						
		MDMA452A1□	4.5	202	28	165	130	150	190	3.2
		MDMA502A1□	5.0	222						
		MDMA082D1□	0.75	144						
		MDMA102D1□	1.0	147	22	145	130	165	6	
		MDMA152D1□	1.5	172	24	165	130	150	190	3.2
		MDMA202D1□	2.0	197						
		MDMA252D1□	2.5	222						
	MDMA302D1□	3.0	247	35	200	114.3	176	233		
	MDMA352D1□	3.5	219							
	MDMA402D1□	4.0	239							
	MDMA452D1□	4.5	202	28	165	130	150	190	3.2	
	MDMA502D1□	5.0	222							
	MDMA082A1□	0.75	169							19
	MDMA102A1□	1.0	172	22	145	130	165	6		
	MDMA152A1□	1.5	197	24	165	130	150	190	3.2	
	MDMA202A1□	2.0	222							
	MDMA252A1□	2.5	247							
	MDMA302A1□	3.0	272	35	200	114.3	176	233		
	MDMA352A1□	3.5	244							
	MDMA402A1□	4.0	264							
	MDMA452A1□	4.5	227	28	165	130	150	190	3.2	
	MDMA502A1□	5.0	247							
MDMA082D1□	0.75	169	19							—
MDMA102D1□	1.0	172	22	145	130	165	6			
MDMA152D1□	1.5	197	24	165	130	150	190	3.2		
MDMA202D1□	2.0	222								
MDMA252D1□	2.5	247								
MDMA302D1□	3.0	272	35	200	114.3	176	233			
MDMA352D1□	3.5	244								
MDMA402D1□	4.0	264								
MDMA452D1□	4.5	227	28	165	130	150	190	3.2		
MDMA502D1□	5.0	247								

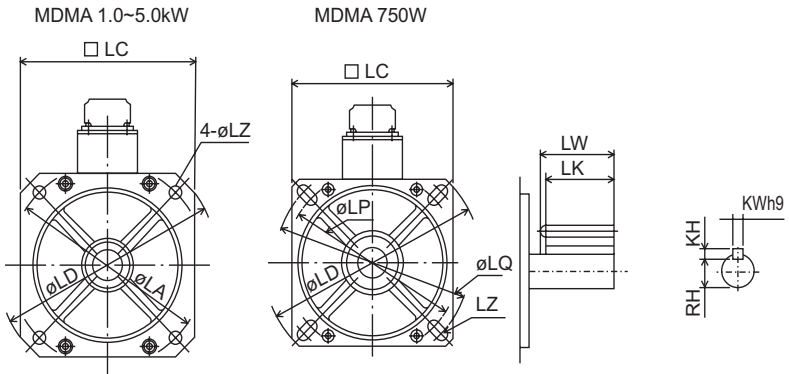

		LF	LP	LQ	LR	LZ	LW	LK	KW	KH	RH	Weight (kg)						
M D M A	Without brake	1 2	130	145	5 5	wide 9	4 5	4 2	6	6	15.5	4.8						
			—	—		9		4 1				8	7	1 8	6.8			
			—	—		6 5		5 5				5 1	2 0	8.5				
			—	—										10.6				
		—	—	7 0	13.5	5 0	1 0	8	3 0	12.8								
		—	—							14.6								
		—	—							16.2								
		—	—							18.8								
		—	—	7 0	13.5	5 0	1 0	8	3 0	21.5								
		—	—							25.0								
		—	—							7 0	13.5	5 0	1 0	8	3 0	4.8		
		—	—													9	4 1	8
	—	—	6 5	5 5	5 1	2 0	8.5											
	—	—					10.6											
	—	—	7 0	13.5	5 0	1 0	8	3 0	12.8									
	—	—							14.6									
	—	—							16.2									
	—	—							18.8									
	—	—	7 0	13.5	5 0	1 0	8	3 0	21.5									
	—	—							25.0									
	With brake	1 2							130	145	5 5	wide 9	4 5	4 2	6	6	15.5	6.5
									—	—		9		4 1				8
			—	—	6 5	5 5	5 1	2 0	10.1									
			—	—					12.5									
—		—	7 0	13.5	5 0	1 0	8	3 0	14.7									
—		—							16.5									
—		—							18.7									
—		—							21.3									
—		—	7 0	13.5	5 0	1 0	8	3 0	25.0									
—		—							28.5									
1 2		130							145	5 5	wide 9	4 5	4 2	6	6	15.5	6.5	
		—							—		9		4 1				8	7
	—	—	6 5	5 5	5 1	2 0	10.1											
	—	—					12.5											
—	—	7 0	13.5	5 0	1 0	8	3 0	14.7										
—	—							16.5										
—	—							18.7										
—	—							21.3										
—	—	7 0	13.5	5 0	1 0	8	3 0	25.0										
—	—							28.5										
1 8	—							—	7 0	13.5	5 0	1 0	8	3 0	6.5			
	—							—							9	4 1	8	7
	—	—	6 5	5 5	5 1	2 0	10.1											
	—	—					12.5											
—	—	7 0	13.5	5 0	1 0	8	3 0	14.7										
—	—							16.5										
—	—							18.7										
—	—							21.3										
—	—	7 0	13.5	5 0	1 0	8	3 0	25.0										
—	—							28.5										

Dimensions

MHMA Series 500W ~ 5.0kW

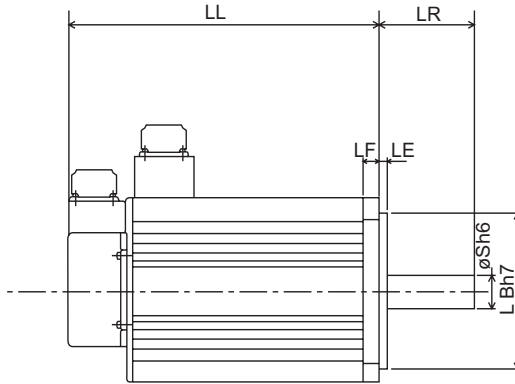

○ Encoder specifications

A1 □ 2500 P/r incremental encoder

D1 □ 17 bits absolute encoder

		Model	Output(W)	LL	S	LA	LB	LC	LD		
MHMA	Without brake	MHMA052A1□	0.5	147	2 2	145	110	130	165		
		MHMA102A1□	1.0	172							
		MHMA152A1□	1.5	197							
		MHMA202A1□	2.0	187	3 5	200	114.3	176	233		
		MHMA302A1□	3.0	202							
		MHMA402A1□	4.0	227							
	MHMA502A1□	5.0	252								
	With brake	Without brake	MHMA052D1□	0.5	147	2 2	145	110	130	165	
			MHMA102D1□	1.0	172						
			MHMA152D1□	1.5	197						
			MHMA202D1□	2.0	187	3 5	200	114.3	176	233	
			MHMA302D1□	3.0	202						
			MHMA402D1□	4.0	227						
		MHMA502D1□	5.0	252							
		With brake	With brake	MHMA052A1□	0.5	172	2 2	145	110	130	165
				MHMA102A1□	1.0	197					
				MHMA152A1□	1.5	222					
				MHMA202A1□	2.0	212	3 5	200	114.3	176	233
MHMA302A1□				3.0	227						
MHMA402A1□	4.0			252							
MHMA502A1□	5.0	277									
With brake	With brake	MHMA052D1□	0.5	172	2 2	145	110	130	165		
		MHMA102D1□	1.0	197							
		MHMA152D1□	1.5	222							
		MHMA202D1□	2.0	212	3 5	200	114.3	176	233		
		MHMA302D1□	3.0	227							
		MHMA402D1□	4.0	252							
MHMA502D1□	5.0	277									

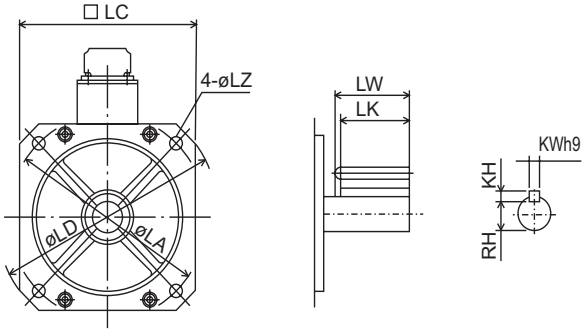

		LE	LF	LR	LZ	LW	LK	KW	KH	RH	Weight (kg)
M H M A	Without brake	6	12	70	9	45	41	8	7	18	5.3
											8.9
											10.0
		3.2	18	80	13.5	55	50	10	8	30	16.0
											18.2
											22.0
										26.7	
		6	12	70	9	45	41	8	7	18	5.3
											8.9
											10.0
		3.2	18	80	13.5	55	50	10	8	30	16.0
											18.2
										22.0	
										26.7	
	With brake	6	12	70	9	45	41	8	7	18	6.9
											9.5
											11.6
		3.2	18	80	13.5	55	50	10	8	30	19.5
											21.7
											25.5
										30.2	
		6	12	70	9	45	41	8	7	18	6.9
											9.5
											11.6
		3.2	18	80	13.5	55	50	10	8	30	19.5
											21.7
											25.5
											30.2

Dimensions

MFMA Series 400W ~ 4.5kW

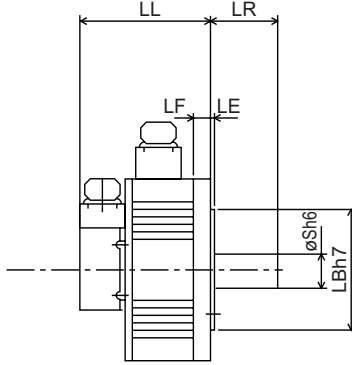

○ Encoder specifications

A1□ 2500 P/r incremental encoder

D1□ 17 bits absolute encoder

		Model	Output(W)	LL	S	LA	LB	LC	LD
MFMA	Without brake	MFMA042A1□	0.4	117	19	145	110	130	165
		MFMA082A1□	0.75	124	22	200	114.3	176	233
		MFMA152A1□	1.5	142	35	235	200	220	268
		MFMA252A1□	2.5	136					
		MFMA352A1□	3.5	144					
		MFMA452A1□	4.5	160					
		MFMA042D1□	0.4	117	19	145	110	130	165
		MFMA082D1□	0.75	124	22	200	114.3	176	233
		MFMA152D1□	1.5	142	35	235	200	220	268
	MFMA252D1□	2.5	136						
	MFMA352D1□	3.5	144						
	MFMA452D1□	4.5	160						
	With brake	MFMA042A1□	0.4	142	19	145	110	130	165
		MFMA082A1□	0.75	149	22	200	114.3	176	233
		MFMA152A1□	1.5	167	35	235	200	220	268
		MFMA252A1□	2.5	163					
		MFMA352A1□	3.5	171					
		MFMA452A1□	4.5	191					
MFMA042D1□		0.4	142	19	145	110	130	165	
MFMA082D1□		0.75	149	22	200	114.3	176	233	
MFMA152D1□		1.5	167	35	235	200	220	268	
MFMA252D1□	2.5	163							
MFMA352D1□	3.5	171							
MFMA452D1□	4.5	191							

MFMA400W ~ 1.5kW

MFMA2.5 ~ 4.5kW

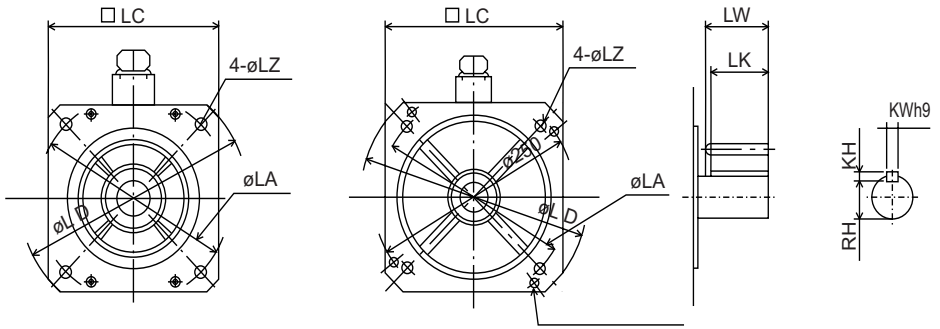

		LE	LF	LR	LZ	LW	LK	KW	KH	RH	Weight (kg)
M F M A	Without brake	6	12	55	9	45	4.2	6	6	15.5	4.7
		3.2	18		13.5		4.1	8	7	18	8.6
		4	16	65	55	5.0	10	8	30	11.0	
				14.8							
		7.0	19.9								
		6	12	55	9	45	4.2	6	6	15.5	4.7
	3.2	18	13.5		4.1		8	7	18	8.6	
	4	16	65	55	5.0	10	8	30	11.0		
			14.8								
	7.0	19.9									
	With brake	6	12	55	9	45	4.2	6	6	15.5	6.7
		3.2	18		13.5		4.1	8	7	18	10.6
4		16	65	55	5.0	10	8	30	14.0		
			17.5								
7.0		19.2									
6		12	55	9	45	4.2	6	6	15.5	6.7	
3.2	18	13.5		4.1		8	7	18	10.6		
4	16	65	55	5.0	10	8	30	14.0			
		17.5									
7.0	19.2										
7.0	24.3										

Dimensions

MGMA Series 300W ~ 4.5kW

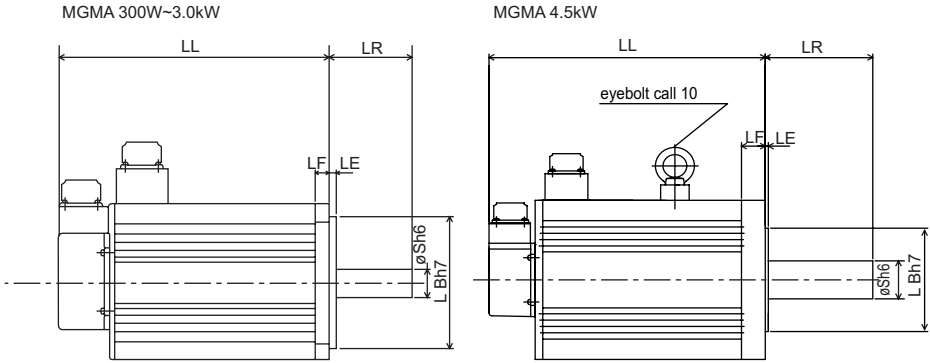

○ Encoder specifications

A1 □ 2500 P/r incremental encoder

C1 □ 17 bits absolute encoder

		Model	Output(W)	LL	S	LA	LB	LC	LD
M G M A	Without brake	MGMA032A1□	0.3	122	2.2	145	110	130	165
		MGMA062A1□	0.6	147					
		MGMA092A1□	0.9	172					
		MGMA122A1□	1.2	162	3.5	200	114.3	176	233
		MGMA202A1□	2.0	182					
		MGMA302A1□	3.0	222					
		MGMA452A1□	4.5	300.5	4.2				
	MGMA032D1□	0.3	122	2.2	145	110	130	165	
	MGMA062D1□	0.6	147						
	MGMA092D1□	0.9	172	3.5	200	114.3	176	233	
	MGMA122D1□	1.2	162						
	MGMA202D1□	2.0	182						
	MGMA302D1□	3.0	222	4.2	300.5	4.2	300.5	300.5	
	MGMA452D1□	4.5	300.5						
M G M A	With brake	MGMA032A1□	0.3	147	2.2	145	110	130	165
		MGMA062A1□	0.6	172					
		MGMA092A1□	0.9	197					
		MGMA122A1□	1.2	187	3.5	200	114.3	176	233
		MGMA202A1□	2.0	207					
		MGMA302A1□	3.0	247	4.2	345.5	4.2	345.5	345.5
		MGMA452A1□	4.5	345.5					
		MGMA032D1□	0.3	147	2.2	145	110	130	165
		MGMA062D1□	0.6	172					
		MGMA092D1□	0.9	197	3.5	200	114.3	176	233
		MGMA122D1□	1.2	187					
		MGMA202D1□	2.0	207					
		MGMA302D1□	3.0	247	4.2	345.5	4.2	345.5	345.5
		MGMA452D1□	4.5	345.5					

MGMA 300W ~ 3.0kW

MGMA 4.5kW

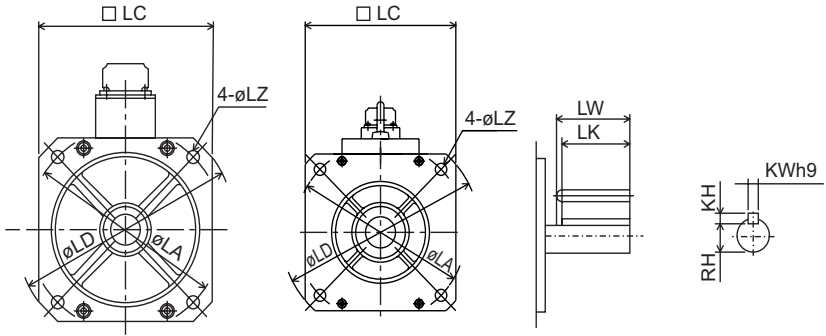

		LE	LF	LR	LZ	LW	LK	KW	KH	RH	Weight (kg)
MGMA	Without brake	6	12	70	9	45	41	8	7	18	5.1 6.8 8.5
		3.2	18	80	13.5	55	50	10	8	30	15.5 17.5 25.0
											2.4
		6	12	70	9	45	41	8	7	18	5.1 6.8 8.5
											3.2
		2.4	113	96	90	12	37	34.0			
	With brake	6	12	70	9	45	41	8	7	18	6.7 8.4 10.0
											3.2
		2.4	113	96	90	12	37	39.5			
		6	12	70	9	45	41	8	7	18	6.7 8.4 10.0
											3.2
		2.4	113	96	90	12	37	39.5			

Dimensions

Driver Type 1 Approximate weight : 1.0 kg

Front panel mount type
(front panel mounting is optional)

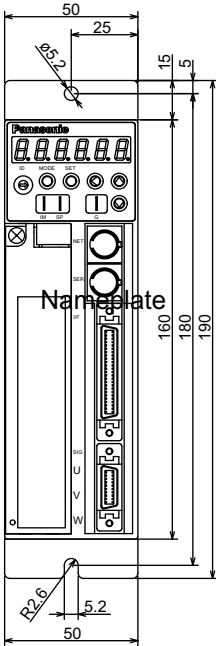

Back panel mount type
(Standard)

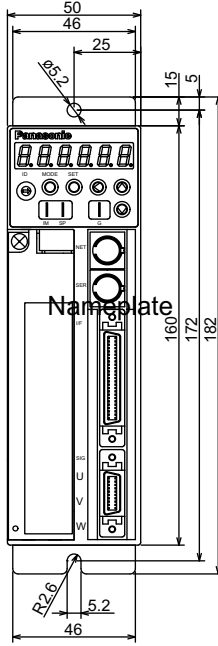

Mounting bracket
(optional: DVOP2100)

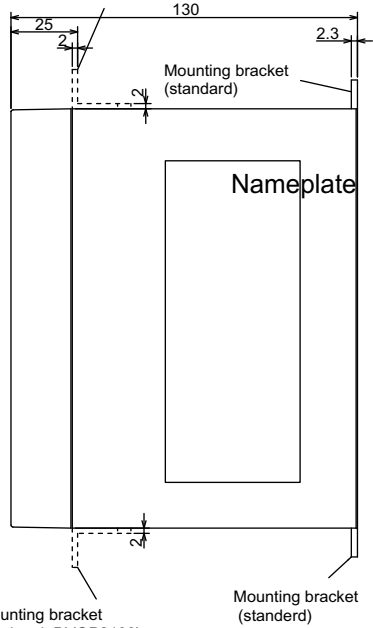

Mounting bracket
(optional: DVOP2100)

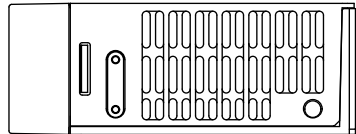

Driver Type 2 Approximate weight : 1.1 kg

Front panel mount type
(front panel mounting is optional)

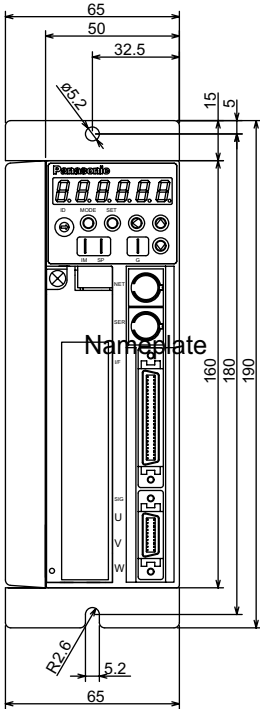

Back panel mount type
(Standard)

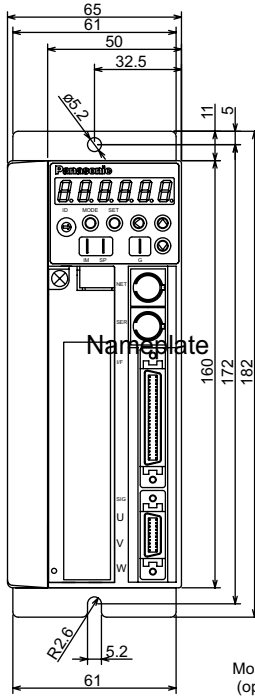

Mounting bracket
(optional: DVOP2100)

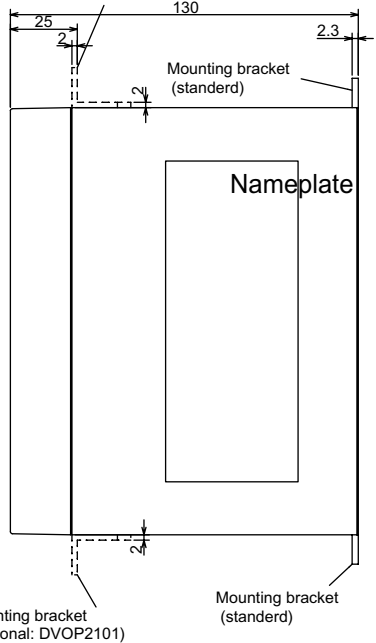

Mounting bracket
(optional: DVOP2101)

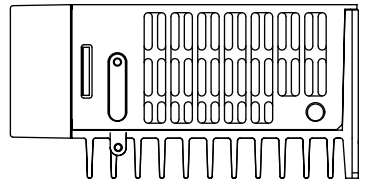

Dimensions

Driver Type 3 Approximate weight : 1.4 kg

Front panel mount type
(front panel mounting is optional)

Back panel mount type
(Standard)

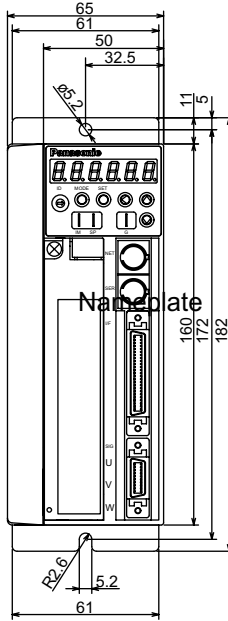
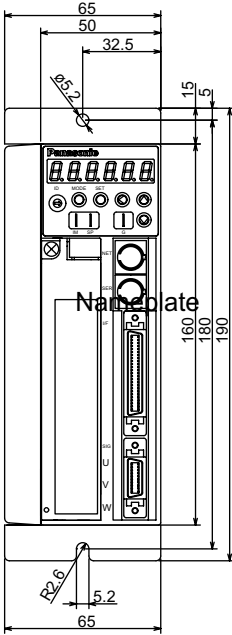

Mounting bracket
(optional: DVOP2101)

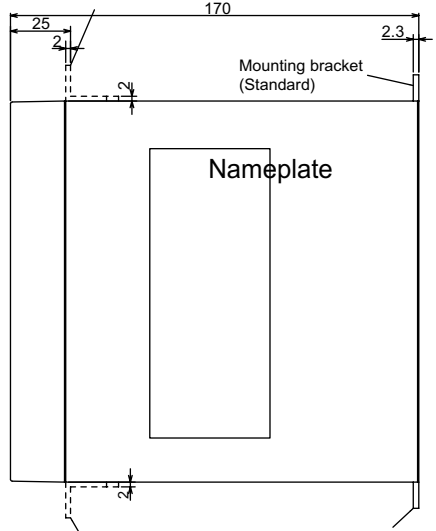

Mounting bracket
(optional: DVOP2101)

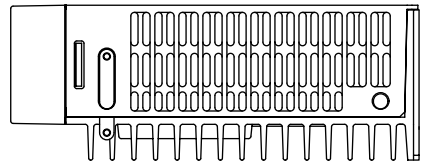

Driver Type 4-2 Approximate weight : 3.8kg

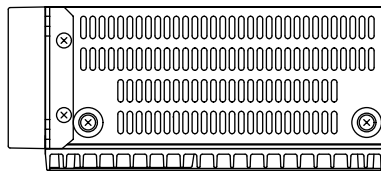
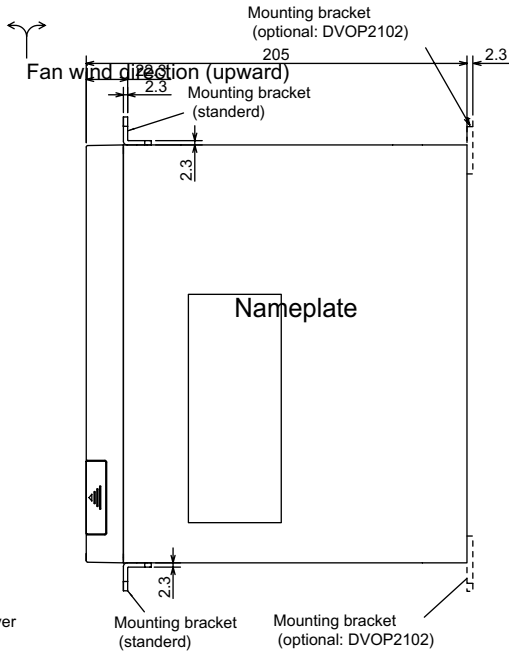
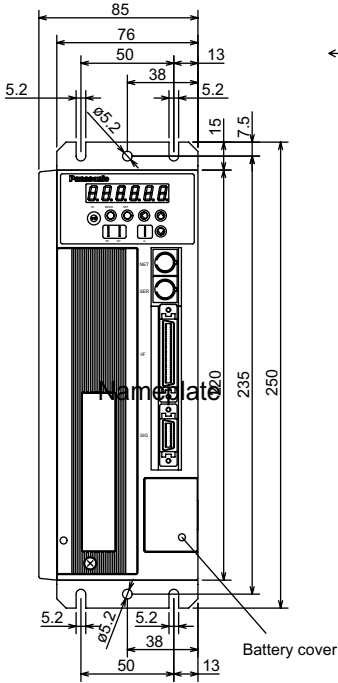

Dimensions

Driver Type 4-3 Approximate weight : 4.2 kg

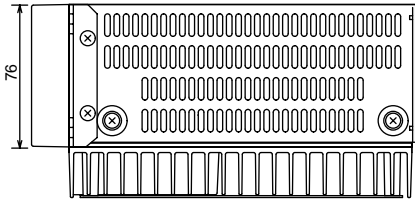
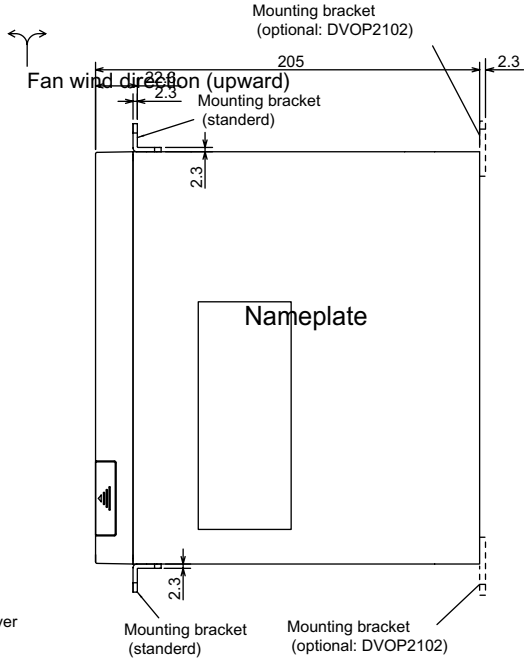
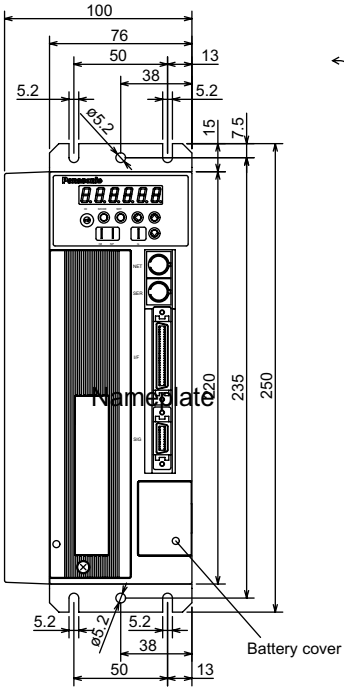

Driver Type 5 Approximate weight : 8 kg

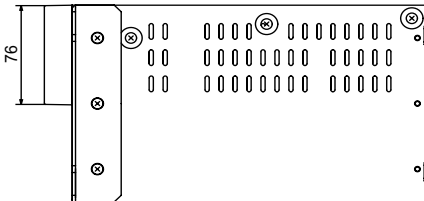
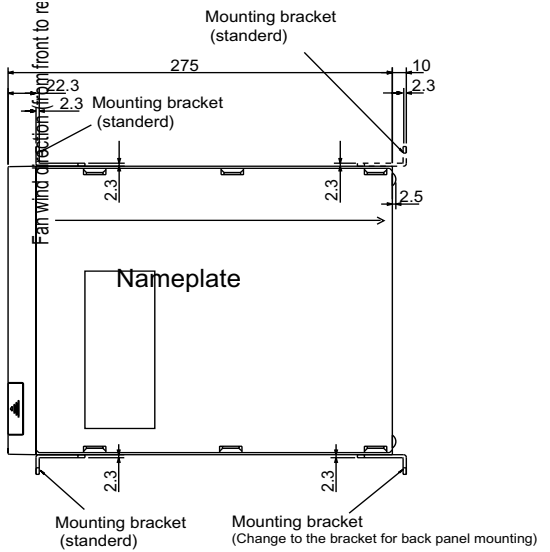
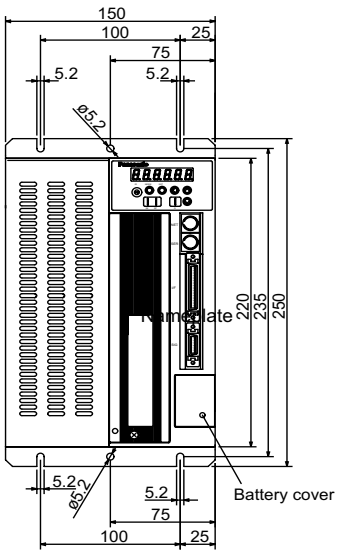

Specifications

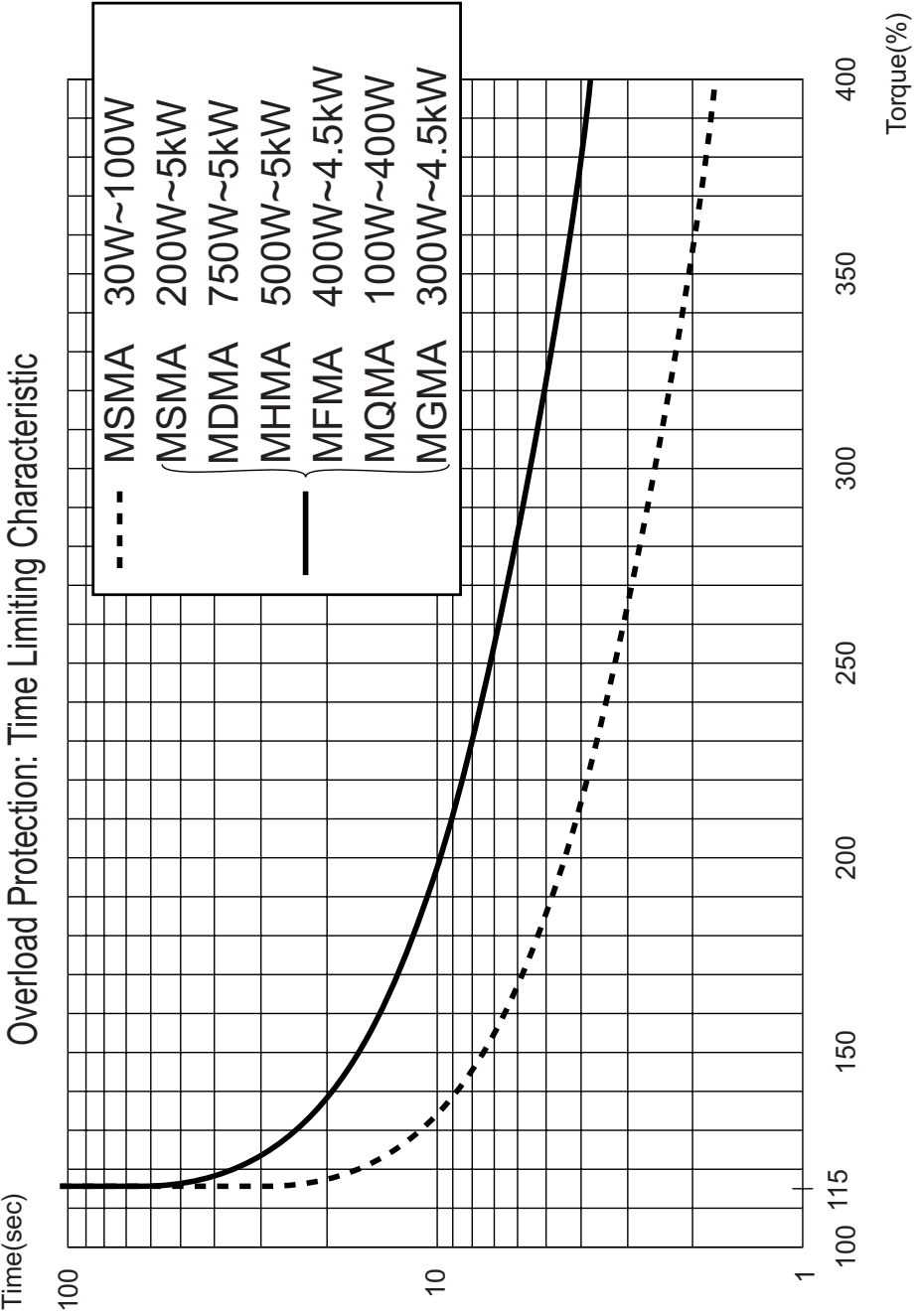

Specifications

Gain Switching Conditions

• Position Control Mode (○: the parameter valid, -: invalid)

Gain switching conditions			Parameters for position control		
Pr31	Switching conditions	Figure	Delay time* ¹	Level	Hysteresis* ²
			Pr32	Pr33	Pr34
0	Fixed to 1st gain		—	—	—
1	Fixed to 2nd gain		—	—	—
2	Gain switching input, 2nd gain selected with GAIN On		—	—	—
3	2nd gain selected with a large torque command differential	A	○	○	○
4	Fixed to 1st gain		—	—	—
5	Large target velocity commanded	C	○	○	○
6	Large position error	D	○	○	○
7	Position command existing	E	○	—	—
8	Positioning incomplete	F	○	—	—

• Velocity Control Mode

Gain switching conditions			Parameters for velocity control		
Pr36	Switching conditions	Figure	Delay time* ¹	Level	Hysteresis* ²
			Pr37	Pr38	Pr39
0	Fixed to 1st gain		—	—	—
1	Fixed to 2nd gain		—	—	—
2	Gain switching input, 2nd gain selected with GAIN On		—	—	—
3	2nd gain selected with a large torque command differential	A	○	○	○
4	2nd gain selected with a large speed command differential	B	○	○	○
5	Large speed command	C	○	○	○

• Gain switching conditions

Gain switching conditions			Torque Control Mode		
Pr3A	Switching conditions	Figure	Delay time* ¹	Level	Hysteresis* ²
			Pr3B	Pr3C	Pr3D
0	Fixed to 1st gain		—	—	—
1	Fixed to 2nd gain		—	—	—
2	Gain switching input, 2nd gain selected with GAIN On		—	—	—
3	2nd gain selected with a large torque command differential	A	○	○	○

Specifications

- *1 Delay time (parameters Pr32, Pr37 and Pr3B) become effective when returning from 2nd gain to 1st gain.
 - *2 For the definitions of hysteresis parameters (Pr34, Pr39 and Pr3D), see the right figure.
- Figures A through F are shown in the next page.

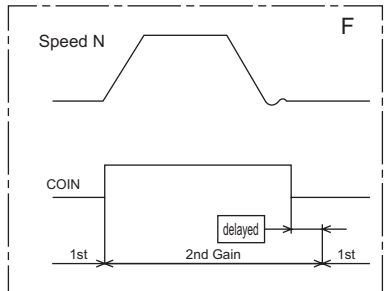
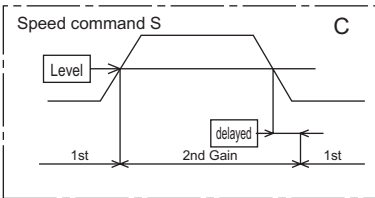
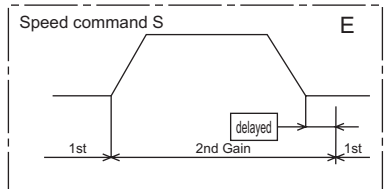
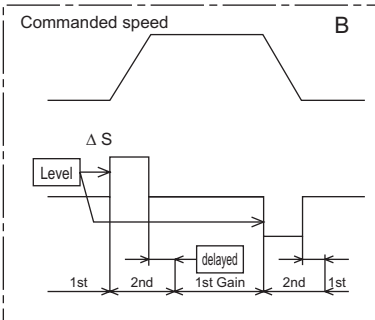
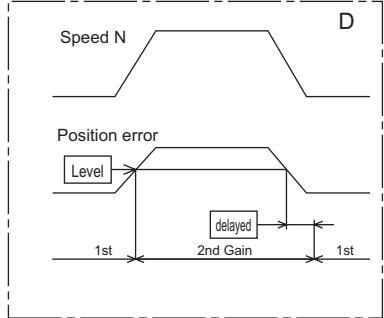
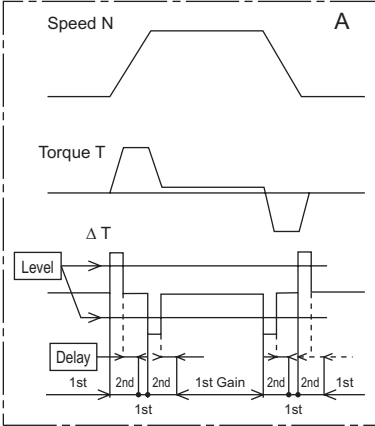
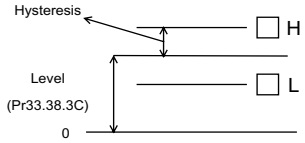

<Notes>

The figures above do not reflect the gain switching timing delay caused by hysteresis (parameters Pr34, Pr39 and Pr3D).

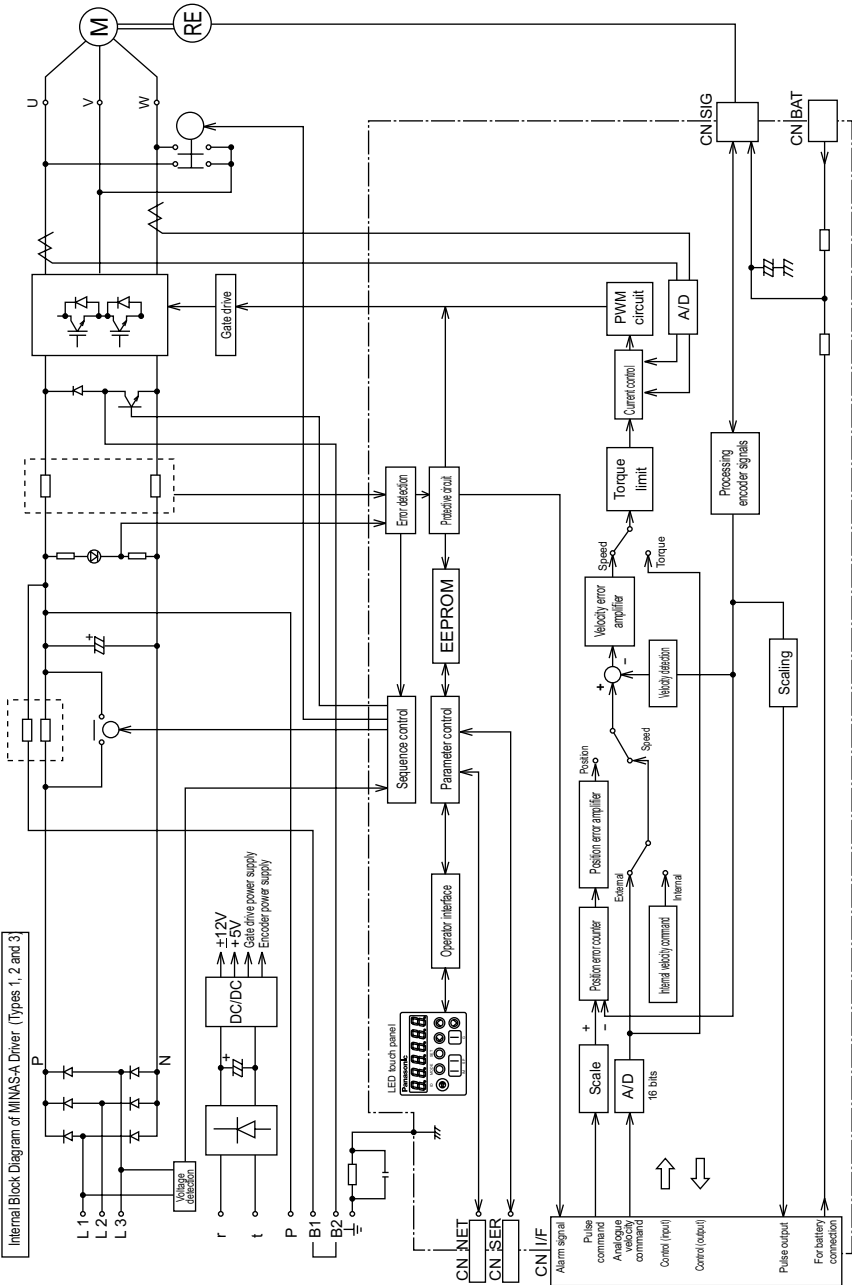

Specifications

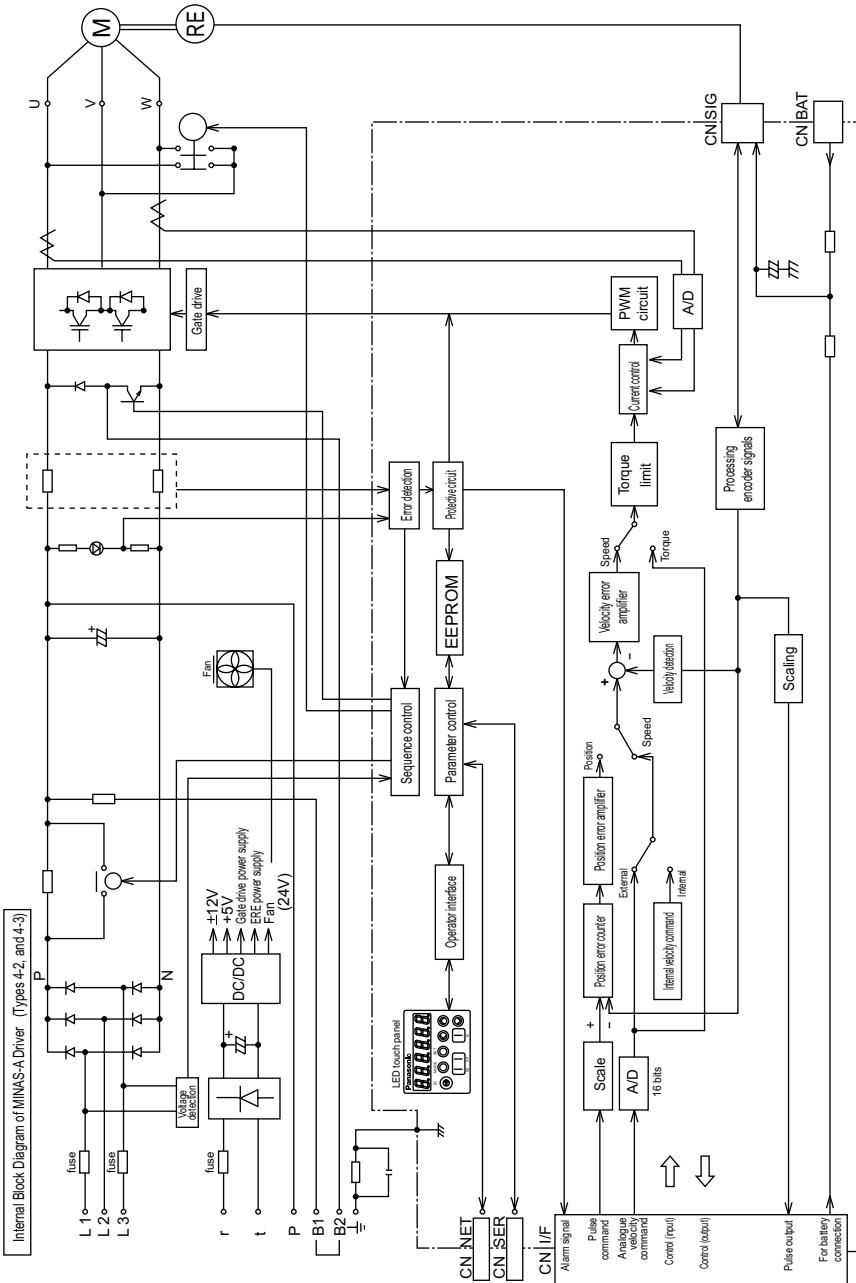

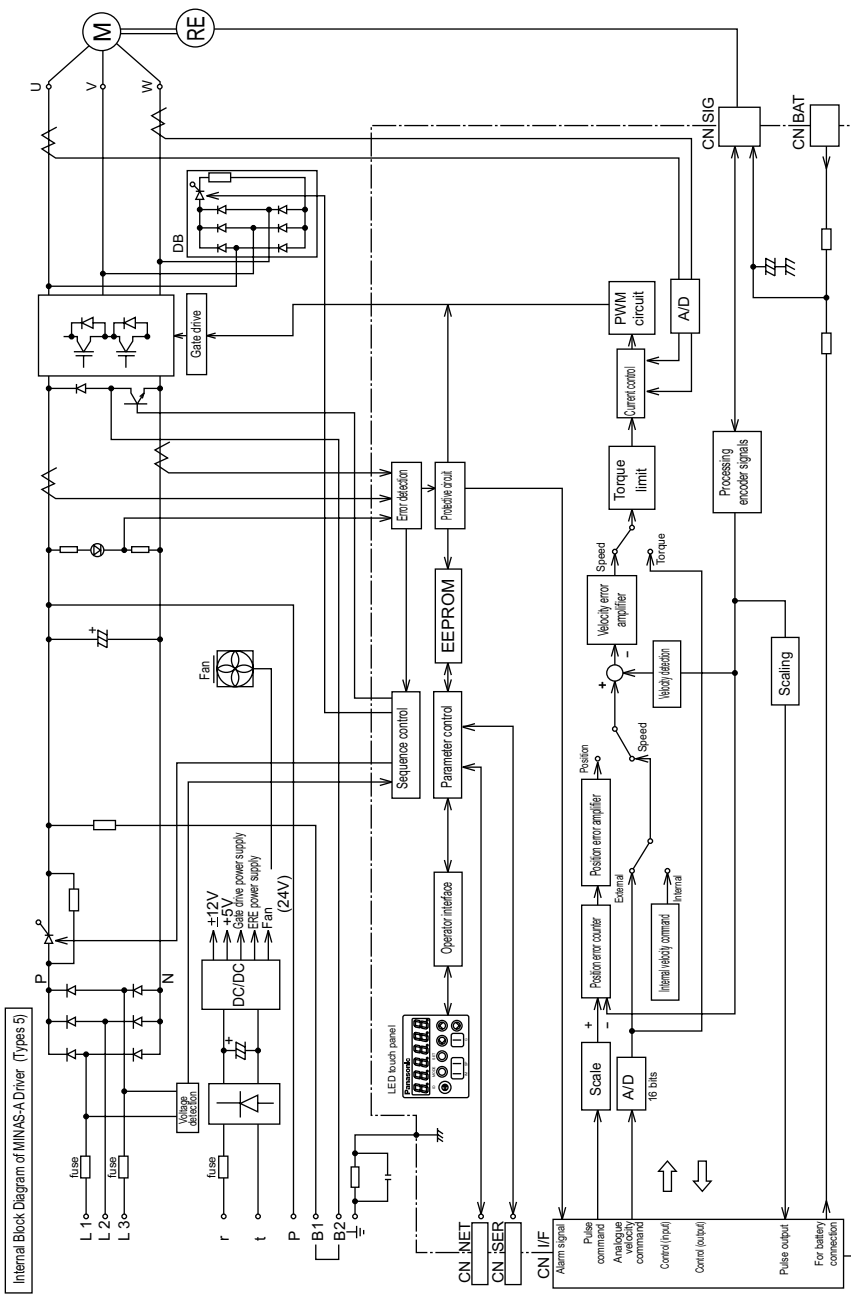

Driver	Power	100V system	Main power supply	Single-phase, AC100 ~ 115V	+ 10% - 15%	50/60Hz	
			Control power supply	Single-phase, AC100 ~ 115V	+ 10% - 15%	50/60Hz	
		200V system	Main power supply	3-phase, AC200 ~ 230V	+ 10% - 15%	50/60Hz	
			Control power supply	Single-phase, AC200 ~ 230V	+ 10% - 15%	50/60Hz	
		Permissible frequency variation		Max. ± 5%			
	Control system			IGBT PWM control (sine wave control)			
	Encoder	Rotary encoder		Incremental encoder, 11 wires, 2500 P/r Absolute encoder, 7 wires, 17 bits			
		Regenerative discharge		Regenerative discharge resistor incorporated (external regenerative discharge resistor connectable)			
	Built-in functions	Dynamic brake		Active after Main Power-Off, Servo-Off, protective function and limit switch.			
		Auto gain tuning		Normal and Real time			
		Electronic gear (command pulse ratio)		Calculated as $\frac{1 \text{ to } 10000}{1 \text{ to } 10000} \times 2^{0 \text{ to } 17}$			
		Scale of feedback pulse		11-wire incremental encoder: 1 to 2500 P/r 7-wire absolute encoder: 1 to 16384 P/r			
		Stores past 14 errors including current one .		Undervoltage, Overvoltage, Overcurrent, Overheat, OverLoad, Regenerative discharge, Encoder error, Position error, Over speed, command pulse scaler error, Error counter over flow, EEPROM data error, Overtravel inhibit input error, Absolute system down error etc			
	Monitor	Digital display		6digits∆7 Segment LED			
		Analogue output (check pins and connector pins)		Velocity monitor: 6V/3000r/min (rated revolution, default)			
		Selects the items to be measured by using a parameter, and measuring range (output impedance of 1kΩ)		Torque monitor: 3V/100% (rated torque, default) Position error pulse number			
	Setting	Communication		RS232C and RS485, max. 16 axes			
		touch panel keys		5 switches (MODE, SET, UP, DOWN and LEFT)			
	Position Control	Max. input pulse frequency		Line driver 500 kpps, Open collector 200 kpps			
		Type		Line driver and open collector			
		Command type		Quadrature pulse command, CW/CCW pulse command and Pulse/direction command			
Velocity control	Velocity control range		Analogue velocity (external) command 1:5000 Internal velocity command 1:5000				
	Acceleration/deceleration time setting		0 to 10s/1000rpm, individual set-up of acceleration and deceleration, S-shaped acceleration/deceleration				
	Analogue velocity (external) command input		0 ~ ±10V				
	Internal velocity command		4 speeds set-up				
Torque control	Analogue torque (external) command input		0 ~ ±10V				
	Torque limit command		Torque limiting individually in CW and CCW				
	Torque command		Shared by speed command - torque or position/torque control : 3V/rated torque (default) Share by CCW torque limit - velocity/torque control: 3V/rated torque (default)				
Rotary encoder	Rotary encoder	A/B phase	Line driver output				
	Feedback signal	Z phase	Output from line driver and open collector				
Input of control signal			See "System Configuration and Wiring".				
Physical structure			Front or back panel mounting (mounting plate optional)				
Approximate weight			See "Outer Views and Dimensions".				
Working environment			See "Installation".				
Frequency response			500Hz (Motor rotor inertia JM = Load inertia JL)				

After-Sale Service Repair

Repair

Ask the seller where the product was purchased for details of repair work.

When the product is installed in a machine or device, consult first the manufacturer of the machine or device.

Information

Customer Service

TEL : 072-870-3057-3110

Operating hours : 9:00 to 17:00, Monday to Saturday

(except Sunday, National holiday and the end/beginning of the year)

Memorandum(Fill in the blanks for convenience in case of inquiry or repair)

Date of purchase	Date:	Model No.	MUDS _____ MUMS _____
Place of purchase	Telephone No.() —		

Industrial and Appliance Motor Division, Motor Co., Matsushita Electric Industrial Co.,Ltd.

1-1, Morofuku 7-chome, Daito, Osaka, Japan 574-0044

TEL : (072) 871-1212

IMB29

M0699-0