

X20(c)BR9300

1 General information

The bus receiver is used to connect the X20 System to the X2X Link. The module is equipped with a feed for the X2X Link as well as the internal I/O supply.

- X2X Link bus receiver
- Feed for X2X Link and internal I/O supply
- Electrical isolation of feed and X2X Link supply
- Redundancy of X2X Link supply possible by operating multiple supply modules simultaneously
- Operation only on the slot to the far left

2 Coated modules

Coated modules are X20 modules with a protective coating for the electronics component. This coating protects X20c modules from condensation and corrosive gases.

The modules' electronics are fully compatible with the corresponding X20 modules.

For simplification purposes, only images and module IDs of uncoated modules are used in this data sheet.

The coating has been certified according to the following standards:

- Condensation: BMW GS 95011-4, 2x 1 cycle
- Corrosive gas: EN 60068-2-60, Method 4, exposure 21 days



3 Order data

Model number	Short description	Figure
	Bus receivers and transmitters	
X20BR9300	X20 bus receiver, X2X Link, supply for X2X Link and internal I/O supply, X20 locking plates (left and right) X20AC0SL1/X20AC0SR1 included	
X20cBR9300	X20 bus receiver, coated, X2X Link, supply for X2X Link and internal I/O supply, X20 locking plates (left and right) X20AC0SL1/X20AC0SR1 included	
	Required accessories	
	Bus modules	
X20BM01	X20 power supply bus module, 24 VDC keyed, internal I/O supply interrupted to the left	
X20BM05	X20 power supply bus module, with node number switch, 24 VDC keyed, internal I/O supply interrupted to the left	
X20cBM01	X20 power supply bus module, coated, 24 VDC keyed, internal I/O supply interrupted to the left	
	Terminal blocks	
X20TB12	X20 terminal block, 12-pin, 24 VDC keyed	
	Optional accessories	
	X2X Link cable	
X67CA0X99.1000	Cable for custom assembly, 100 m	
X67CA0X99.5000	Cable for custom assembly, 500 m	

Table 1: X20BR9300, X20cBR9300 - Order data

Information:

This module is NOT PERMITTED to be used together with continuous power supply modules (e.g. X20BM11 or X20BM15) since this can result in problems with X2X Link!

4 Technical data

Model number	X20BR9300	X20cBR9300
Short description		
Bus receiver	X2X Link bus receiver with supply for I/O and bus	
General information		
B&R ID code	0x1BC1	0xDD48
Status indicators	X2X bus function, overload, operating status, module status	
Diagnostics		
Module run/error	Yes, using status LED and software	
Overload	Yes, using status LED and software	
X2X bus function	Yes, using status LED	
Power consumption ¹⁾		
Bus	1.62 W	
Internal I/O	0.6 W	
Additional power dissipation caused by the actuators (resistive) [W]	-	
Electrical isolation		
I/O feed - I/O power supply	No	
X2X Link feed - X2X Link power supply	Yes	
Certification		
CE	Yes	
KC	Yes	-
UL	cULus E115267 Industrial control equipment	
HazLoc	cCSAus 244665 Process control equipment for hazardous locations Class I, Division 2, Groups ABCD, T5	
ATEX	Zone 2, II 3G Ex nA nC IIA T5 Gc IP20, Ta = 0 - Max. 60°C FTZÚ 09 ATEX 0083X	
GOST-R	Yes	
X2X Link power supply input		
Input voltage	24 VDC -15 % / +20 %	
Input current	Max. 0.7 A	
Fuse	Integrated, cannot be replaced	
Reverse polarity protection	Yes	
X2X Link power supply output		
Nominal output power	7 W	
Parallel connection	Yes ²⁾	
Redundant operation	Yes	
Overload characteristics	Short circuit / temporary overload protection	
Input I/O power supply		
Input voltage	24 VDC -15 % / +20 %	
Fuse	Required line fuse: Max. 10 A, slow-blow	
Reverse polarity protection	No	
Output I/O power supply		
Rated output voltage	24 VDC	
Behavior if a short circuit occurs	Required line fuse	
Permitted contact load	10 A	
Operating conditions		
Mounting orientation		
Horizontal	Yes	
Vertical	Yes	
Installation at elevations above sea level		
0 to 2000 m	No limitations	
>2000 m	Reduction of ambient temperature by 0.5°C per 100 m	
EN 60529 protection	IP20	
Environmental conditions		
Temperature		
Operation		
Horizontal installation	-25 to 60°C	
Vertical installation	-25 to 50°C	
Derating	See section "Derating"	
Storage	-40 to 85°C	
Transport	-40 to 85°C	

Table 2: X20BR9300, X20cBR9300 - Technical data

Model number	X20BR9300	X20cBR9300
Relative humidity		
Operation	5 to 95%, non-condensing	Up to 100%, condensing
Storage	5 to 95%, non-condensing	
Transport	5 to 95%, non-condensing	
Mechanical characteristics		
Note	Order 1x X20TB12 terminal block separately Order 1x X20BM01 supply bus module separately Left and right X20 locking plates included in delivery	Order 1x X20TB12 terminal block separately Order 1x X20cBM01 supply bus module separately Left and right X20 locking plates included in delivery
Spacing	12.5 ^{+0.2} mm	

Table 2: X20BR9300, X20cBR9300 - Technical data

- The specified values are maximum values. The exact calculation is also available for download as a data sheet with the other module documentation on the B&R website.
- In parallel operation, only 75% of the rated power can be assumed. It is important to make sure that all power supplies operated in parallel are switched on and off at the same time.

5 LED status indicators

For a description of the various operating modes, see section "Additional information - Diagnostic LEDs" of the X20 system user's manual.

Figure	LED	Color	Status	Description
	r	Green	Off	No power to module
			Single flash	RESET mode
			Blinking	PREOPERATIONAL mode
	e	Red	On	RUN mode
			Off	No power to module or everything OK
	e + r	Red on / Green single flash	Double flash	LED indicates one of the following states: <ul style="list-style-type: none"> X2X Link power supply is overloaded I/O supply too low Input voltage for X2X Link supply too low
			Invalid firmware	
	X	Orange	Off	No communication at the X2X Link
			On	X2X Link communication in progress
	l	Red	Off	X2X Link supply in the acceptable range
On			X2X Link power supply is overloaded Solution: Use an additional feed module X20PS3300	

6 Pinout

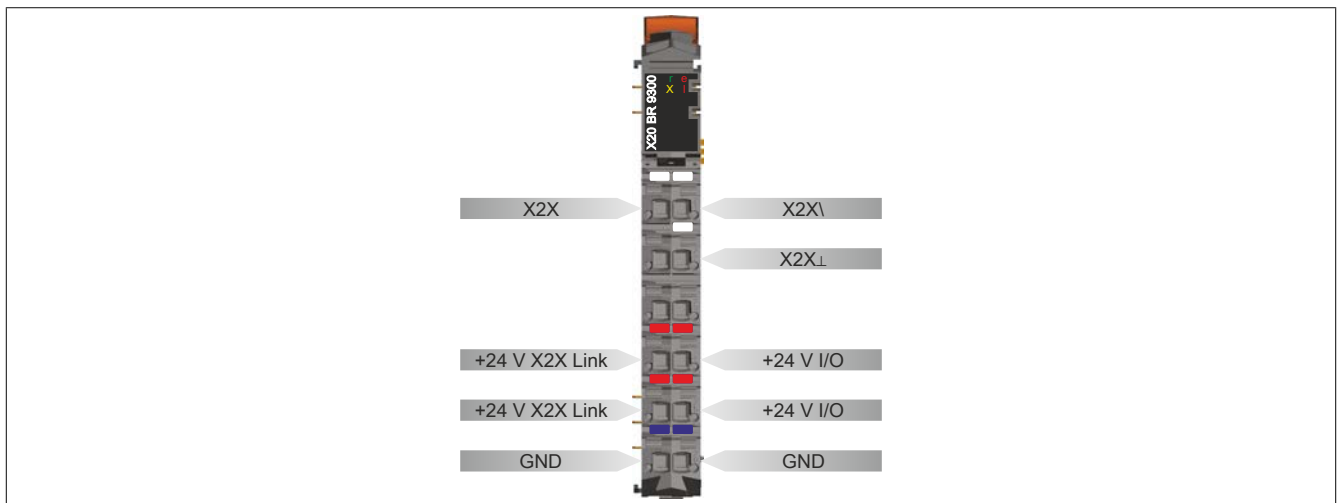

7 Connection examples

With two separate supplies

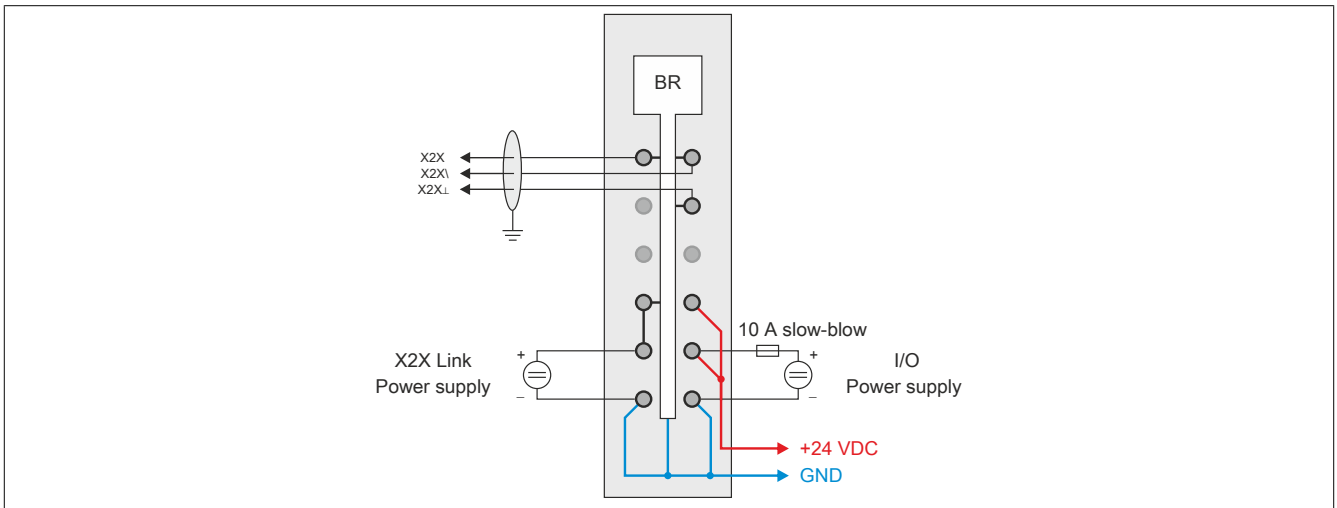

With a supply and jumper

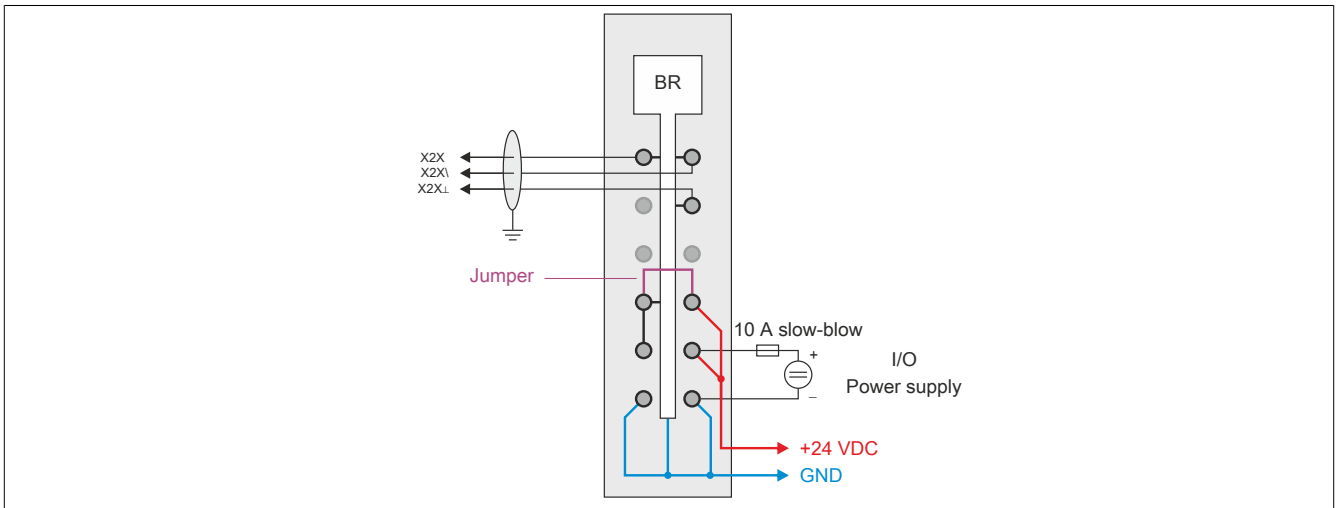

8 Derating

The nominal output power for the power supply is 7 W. Derating may need to be taken into account depending on the mounting orientation.

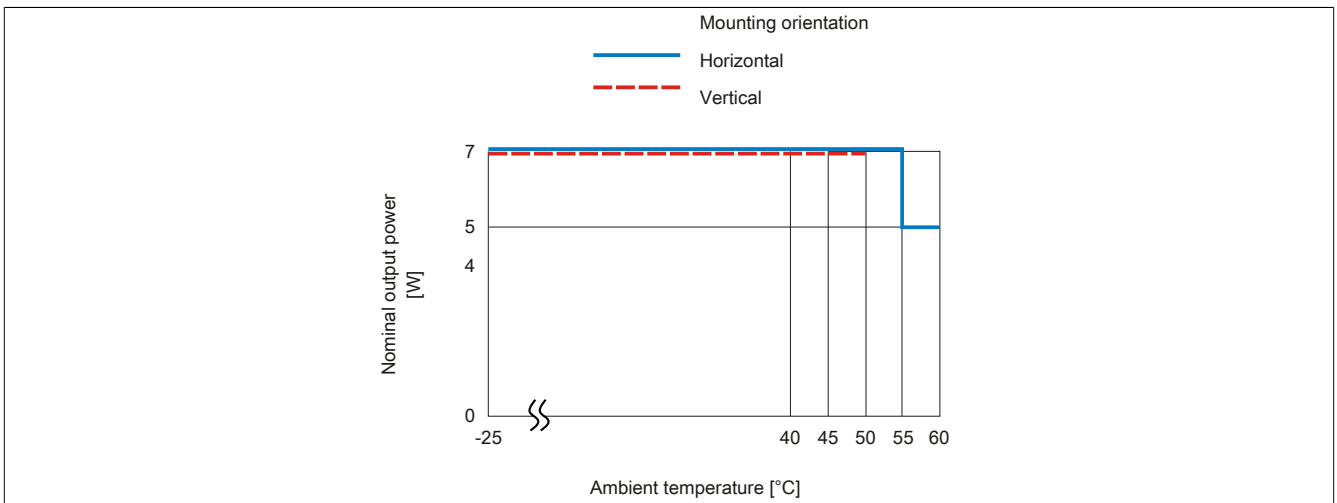

9 Register description

9.1 General data points

In addition to the registers listed in the register description, the module also has other more general data points. These registers are not specific to the module but contain general information such as serial number and hardware version.

These general data points are listed in section "Additional information - General data points" of the X20 system user's manual.

9.2 Function model 0 - Standard

Register	Name	Data type	Read		Write	
			Cyclic	Non-cyclic	Cyclic	Non-cyclic
0	Module status	USINT	•			
	StatusInput01	Bit 0				
	StatusInput02	Bit 2				
2	SupplyCurrent	USINT	•			
4	SupplyVoltage	USINT	•			

9.3 Function model 254 - Bus controller

Register	Offset ¹⁾	Name	Data type	Read		Write	
				Cyclic	Non-cyclic	Cyclic	Non-cyclic
0	0	Module status	UINT	•			
		StatusInput01	Bit 0				
		StatusInput02	Bit 2				
2	2	SupplyCurrent	UINT	•			
4	4	SupplyVoltage	UINT	•			

1) The offset specifies the position of the register within the CAN object.

9.3.1 CAN I/O bus controller

The module occupies 1 analog logical slot on CAN I/O.

9.4 Module status

Name:
Module status

The following voltage and current states of the module are monitored in this register:

Bus supply current:	A bus supply current of >2.3A is displayed as a warning.
Bus supply voltage:	A bus supply voltage of <4.7 V is displayed as a warning.
24 VDC I/O supply voltage:	An I/O supply voltage of <20.4 V is displayed as a warning.

Function model	Data type	Value
0 - Standard	USINT	See bit structure.
254 - Bus controller	UINT	See bit structure.

Bit structure:

Bit	Name	Value	Information
0	StatusInput01	0	No error
		1	Warning if overcurrent (>2.3 A) or undervoltage (<4.7 V)
1	Reserved	0	
2	StatusInput02	0	I/O power supply above the warning threshold of 20.4 V
		1	I/O power supply below the warning threshold of 20.4 V
3 - x	Reserved	0	

9.5 Bus supply current

Name:
SupplyCurrent

This register displays the bus supply current measured at a resolution of 0.1 A.

Function model	Data type
0 - Standard	USINT
254 - Bus controller	UINT

9.6 Bus supply voltage

Name:
SupplyVoltage

This register displays the bus supply voltage measured at a resolution of 0.1 V.

Function model	Data type
0 - Standard	USINT
254 - Bus controller	UINT

9.7 Minimum cycle time

The minimum cycle time defines how far the bus cycle can be reduced without communication errors occurring. Note that very fast cycles decrease the idle time available for handling monitoring, diagnostics and acyclic commands.

Minimum cycle time
100 μ s

9.8 Minimum I/O update time

The minimum I/O update time defines how far the bus cycle can be reduced while still allowing an I/O update to take place in each cycle.

Minimum I/O update time
2 ms