

X20(c)DI9371

1 General Information

The module is equipped with 12 inputs for 1-wire connections. The module is designed for sink input wiring.

- 12 digital inputs
- Sink connection
- 1-wire connections
- Software input filter can be configured for entire module

2 Coated modules

Coated modules are X20 modules with a protective coating for the electronics component. This coating protects X20c modules from condensation and corrosive gases.

The modules' electronics are fully compatible with the corresponding X20 modules.

For simplification purposes, only images and module IDs of uncoated modules are used in this data sheet.

The coating has been certified according to the following standards:

- Condensation: BMW GS 95011-4, 2x 1 cycle
- Corrosive gas: EN 60068-2-60, Method 4, exposure 21 days



3 Order data

Model number	Short description	Figure
	Digital inputs	
X20DI9371	X20 digital input module, 12 inputs, 24 VDC, sink, configurable input filter, 1-wire connections	
X20cDI9371	X20 digital input module, coated, 12 inputs, 24 VDC, sink, configurable input filter, 1-wire connections	
	Required accessories	
	Bus modules	
X20BM11	X20 bus module, 24 VDC keyed, internal I/O supply continuous	
X20BM15	X20 bus module, with node number switch, 24 VDC keyed, internal I/O supply continuous	
X20cBM11	X20 bus module, coated, 24 VDC keyed, internal I/O supply continuous	
	Terminal blocks	
X20TB12	X20 terminal block, 12-pin, 24 VDC keyed	

Table 1: X20DI9371, X20cDI9371 - Order data

4 Technical data

Model number	X20DI9371	X20cDI9371
Short description		
I/O module	12 digital inputs 24 VDC for 1-wire connections	
General information		
B&R ID code	0x1B95	0xD574
Status indicators	I/O function per channel, operating state, module status	
Diagnostics		
Module run/error	Yes, using status LED and software	
Power consumption		
Bus	0.18 W	
Internal I/O	-	
External I/O	1.75 W	
Additional power dissipation caused by the actuators (resistive) [W]	-	
Electrical isolation		
Channel - Bus	Yes	
Channel - Channel	No	
Certification		
CE	Yes	
KC	Yes	-
UL	cULus E115267 Industrial control equipment	
HazLoc	cCSAus 244665 Process control equipment for hazardous locations Class I, Division 2, Groups ABCD, T5	
ATEX	Zone 2, II 3G Ex nA nC IIA T5 Gc IP20, Ta = 0 - Max. 60°C FTZÚ 09 ATEX 0083X	
DNV GL	Temperature: B (0 - 55°C) Humidity: B (up to 100%) Vibration: B (4 g) EMC: B (Bridge and open deck)	
LR	ENV1	
GOST-R	Yes	
Digital inputs		
Nominal voltage	24 VDC	
Input voltage	24 VDC -15 % / +20 %	
Input current at 24 VDC	Typ. 3.75 mA	
Input characteristics in accordance with EN 61131-2	Type 1	
Input filter		
Hardware	≤100 µs	
Software	Default 1 ms, configurable between 0 and 25 ms in 0.2 ms intervals	
Connection type	1-wire connections	
Input circuit	Sink	
Input resistance	Typ. 6.4 kΩ	
Switching threshold		
Low	<5 VDC	
High	>15 VDC	
Isolation voltage between channel and bus	500 V _{eff}	
Operating conditions		
Mounting orientation		
Horizontal	Yes	
Vertical	Yes	
Installation at elevations above sea level		
0 to 2000 m	No limitations	
>2000 m	Reduction of ambient temperature by 0.5°C per 100 m	
EN 60529 protection	IP20	
Environmental conditions		
Temperature		
Operation		
Horizontal installation	-25 to 60°C	
Vertical installation	-25 to 50°C	
Derating	See section "Derating"	
Storage	-40 to 85°C	
Transport	-40 to 85°C	

Table 2: X20DI9371, X20cDI9371 - Technical data

Model number	X20DI9371	X20cDI9371
Relative humidity		
Operation	5 to 95%, non-condensing	Up to 100%, condensing
Storage	5 to 95%, non-condensing	
Transport	5 to 95%, non-condensing	
Mechanical characteristics		
Note	Order 1x X20TB12 terminal block separately Order 1x X20BM11 bus module separately	Order 1x X20TB12 terminal block separately Order 1x X20cBM11 bus module separately
Spacing	12.5 ^{+0.2} mm	

Table 2: X20DI9371, X20cDI9371 - Technical data

5 Status LEDs

For a description of the various operating modes, see section "Additional information - Diagnostic LEDs" of the X20 system user's manual.

Image	LED	Color	Status	Description
	r	Green	Off	No power to module
			Single flash	RESET mode
			Blinking	PREOPERATIONAL mode
			On	RUN mode
	e	Red	Off	Module supply not connected or everything OK
	e + r	Red on / Green single flash		Invalid firmware
	1 - 12	Green		Input status of the corresponding digital input

6 Pinout

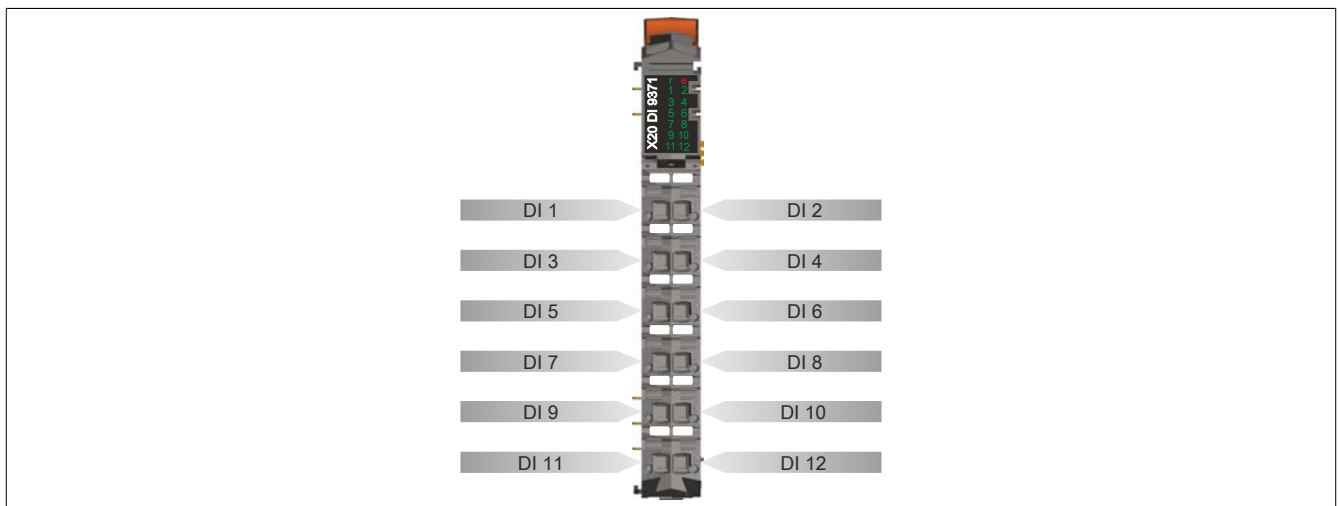

7 Connection example

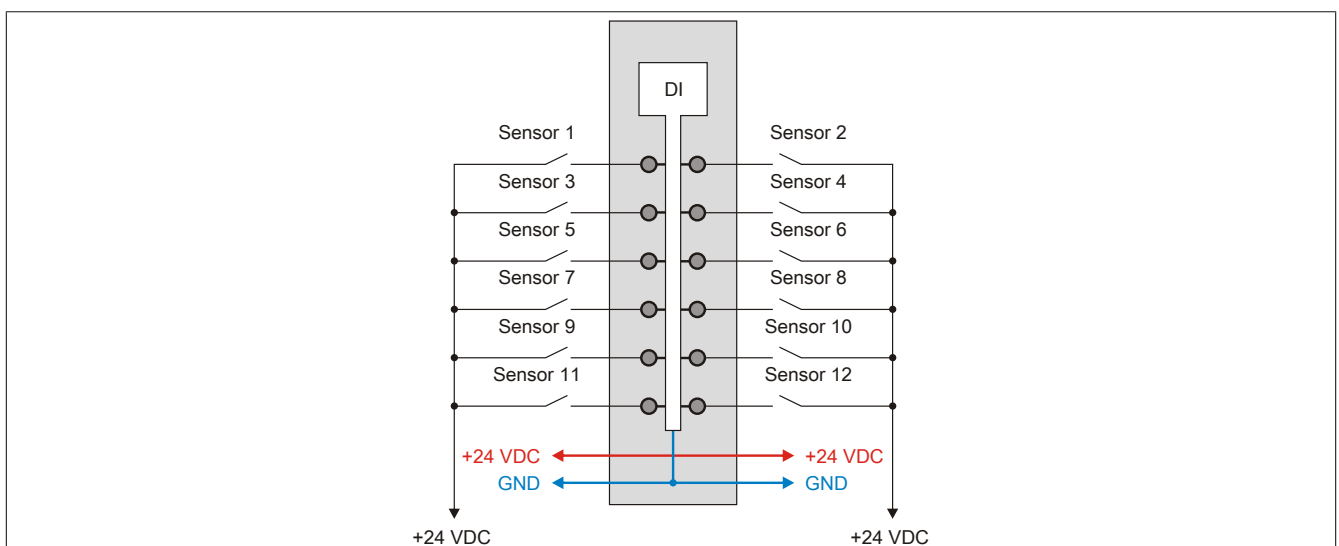

8 Input circuit diagram

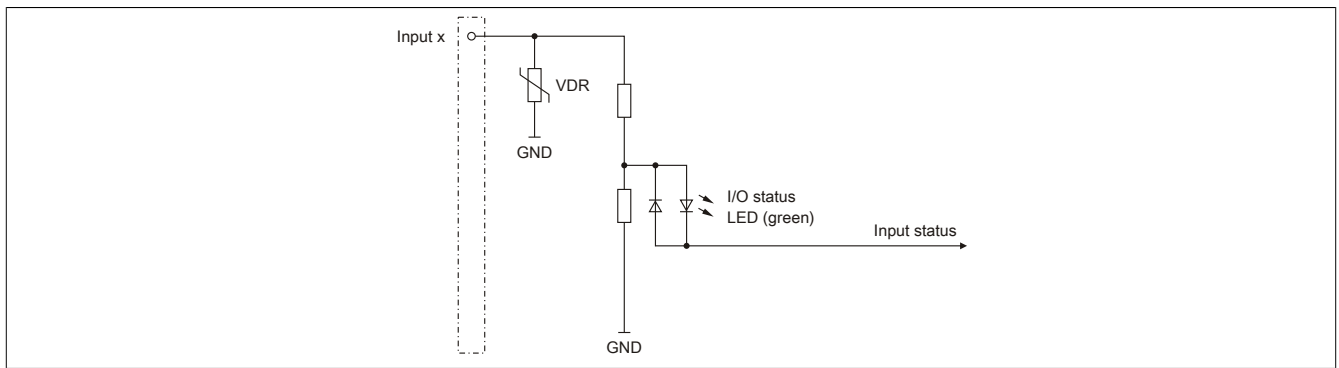

9 Input filter

An input filter is available for each input. The input delay can be set using register "[ConfigOutput01](#)" on page 7. Disturbance pulses which are shorter than the input delay are suppressed by the input filter.

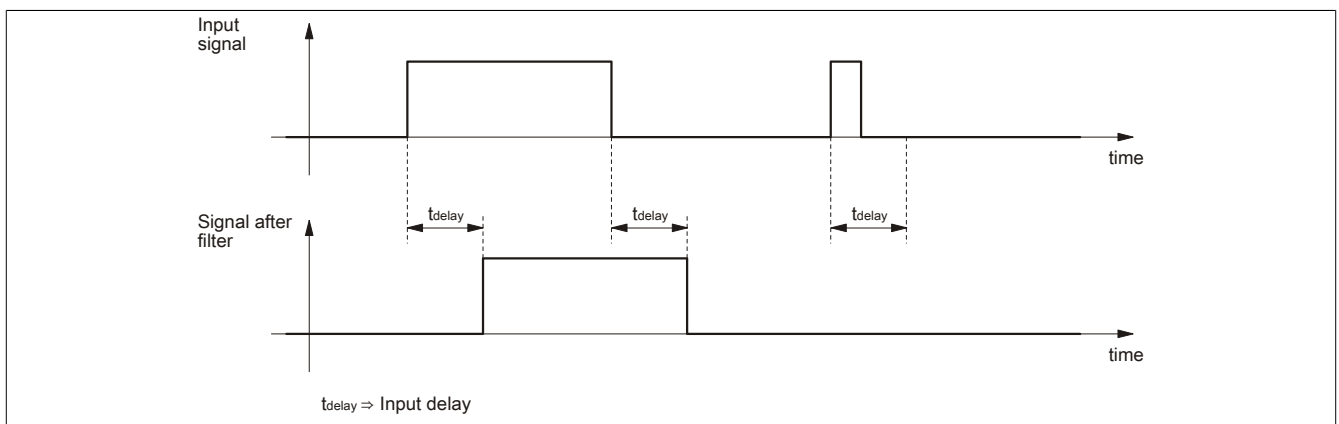

10 Derating

Be aware of the derating values below for the simultaneity factor.

Derating of simultaneity factor at 24 VDC input voltage

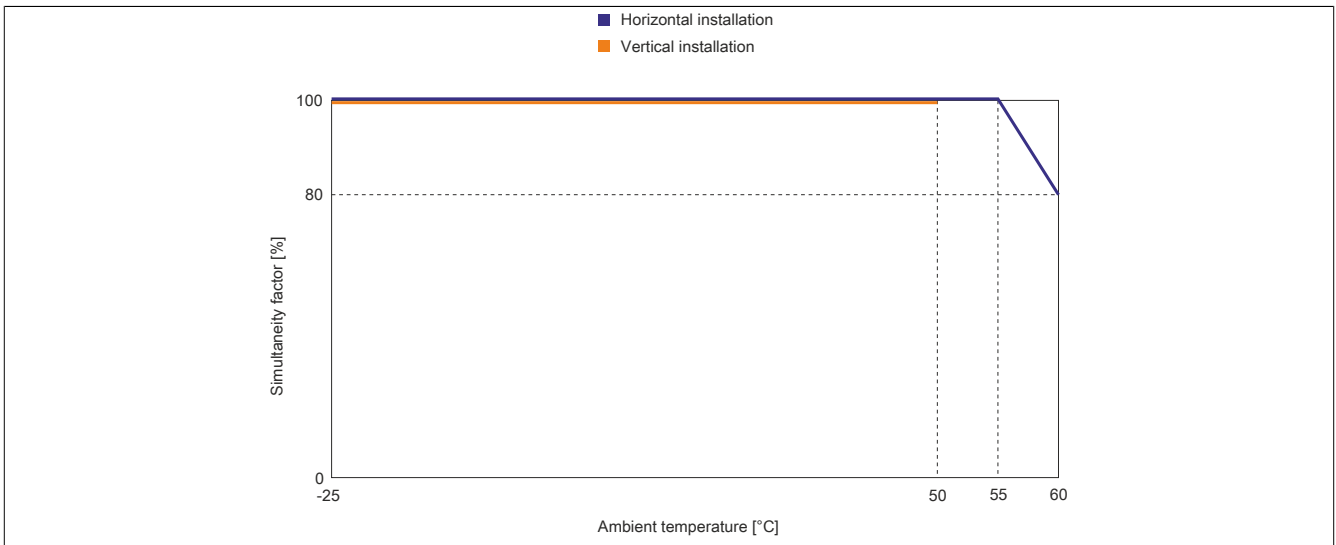

Derating of simultaneity factor at 28.8 VDC input voltage

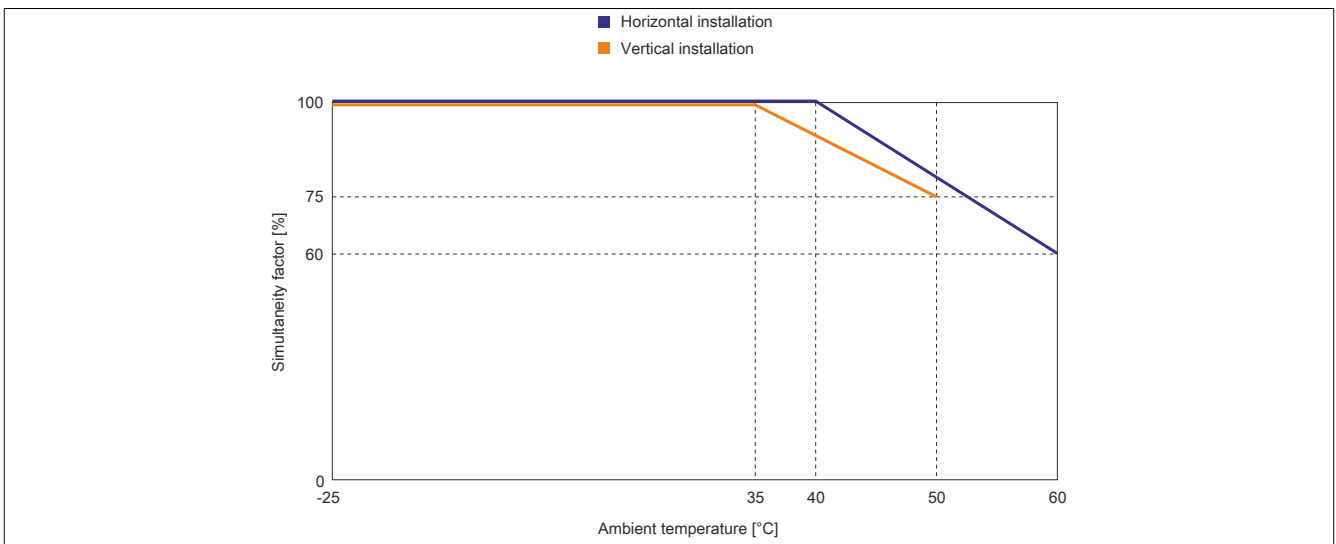

11 Register description

11.1 General data points

In addition to the registers listed in the register description, the module also has other more general data points. These registers are not specific to the module but contain general information such as serial number and hardware version.

These general data points are listed in section "Additional information - General data points" of the X20 system user's manual.

11.2 Function model 0 - Standard

Register	Fixed offset	Name	Data type	Read		Write	
				Cyclic	Acyclic	Cyclic	Acyclic
-	1	DigitalInput	UINT	•			
0	1	Input status of digital inputs 1 to 8	USINT				
		DigitalInput01	Bit 0				
					
		DigitalInput08	Bit 7				
1	2	Input status of digital inputs 9 to 12	USINT	•			
		DigitalInput09	Bit 0				
					
		DigitalInput12	Bit 3				
18	-	ConfigOutput01	USINT				•

Fixed modules require their data points to be in a specific order in the X2X frame. Cyclic access occurs according to a predefined offset, not based on the register address.

Acyclic access continues to be based on the register numbers.

11.3 Function model 254 - Bus Controller

Register	Offset ¹⁾	Name	Data type	Read		Write	
				Cyclic	Acyclic	Cyclic	Acyclic
0	0	Input status of digital inputs 1 to 8	USINT	•			
		DigitalInput01	Bit 0				
					
		DigitalInput08	Bit 7				
1	1	Input status of digital inputs 9 to 12	USINT	•			
		DigitalInput09	Bit 0				
					
		DigitalInput12	Bit 3				
18	-	ConfigOutput01	USINT				•

1) The offset specifies where the register is within the CAN object.

11.3.1 CAN I/O bus controller

The module occupies 2 digital logical slots on CAN I/O.

11.4 Digital inputs

Unfiltered

The input state is collected with a fixed offset to the network cycle and transferred in the same cycle.

Filtered

The filtered status is collected with a fixed offset to the network cycle and transferred in the same cycle. Filtering takes place asynchronously to the network in multiples of 200 µs with a network-related jitter of up to 50 µs.

11.4.1 Digital input filter

Name:

ConfigOutput01

This register can be used to specify the filter value for all digital inputs.

The filter value can be configured in steps of 100 μ s. It makes sense to enter values in steps of 2, however, since the input signals are sampled every 200 μ s.

Data type	Value	Filter
USINT	0	No software filter (default value)
	2	0.2 ms

	250	25 ms - Higher values are limited to this value

11.4.2 Input state of digital inputs 1 to 12

Name:

DigitalInput or

DigitalInput01 to DigitalInput12

This register indicates the input state of digital inputs 1 to 12.

Only function model 0 - Standard

The "Packed inputs" setting in the Automation Studio I/O configuration is used to determine whether all of the bits from these registers should be set up individually as data points in the Automation Studio I/O mapping ("DigitalInput01" to "DigitalInput12") or whether this register should be displayed as an individual UINT data point ("DigitalInput").

Data type	Values	Information
UINT	0 to 4095	Packed inputs = On
USINT	See bit structure.	Packed inputs = Off or Function model <> 0 - Standard

Bit structure:

Register 0

Bit	Name	Value	Information
0	DigitalInput01	0 or 1	Input state - Digital input 1
...		...	
7	DigitalInput08	0 or 1	Input state - Digital input 8

Register 1

Bit	Name	Value	Information
0	DigitalInput09	0 or 1	Input state - Digital input 9
...		...	
3	DigitalInput12	0 or 1	Input state - Digital input 12

11.5 Minimum cycle time

The minimum cycle time defines how far the bus cycle can be reduced without communication errors occurring. Note that very fast cycles decrease the idle time available for handling monitoring, diagnostics and acyclic commands.

Minimum cycle time	
Without filtering	100 μ s
With filtering	150 μ s

11.6 Minimum I/O update time

The minimum I/O update time defines how far the bus cycle can be reduced while still allowing an I/O update to take place in each cycle.

Minimum I/O update time	
Without filtering	100 μ s
With filtering	200 μ s